



Mohave Hot Gas Defrost Installation & Operation

H-IM-HGDO

NOVEMBER 2021

Part Number 25007401

Replaces February 2021

Mohave™

THE ADVANCED HOT GAS DEFROST SYSTEM

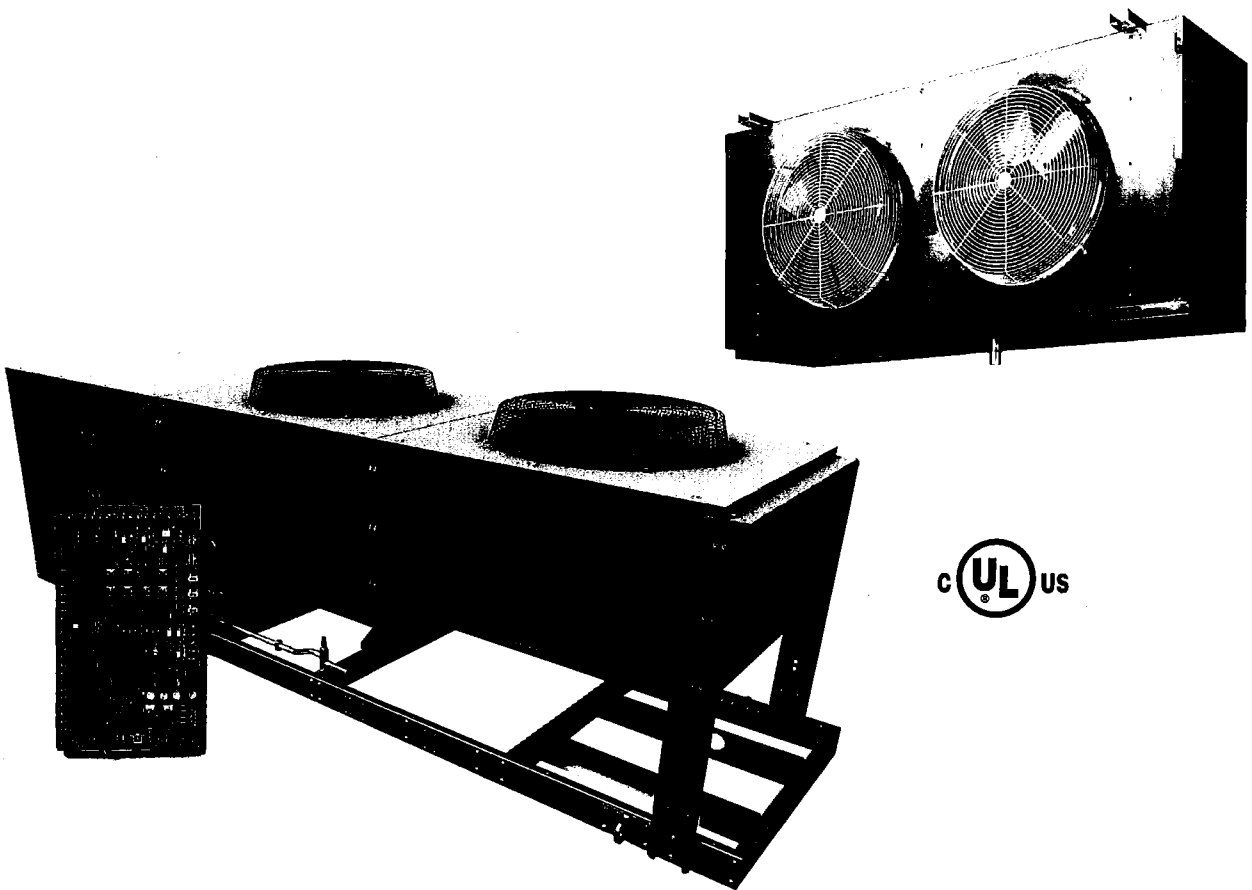

Installation, Start-Up, Operation and
Troubleshooting with Wiring Diagrams

Table of Contents

Controller Quick Reference Guide	3-5
Receiving and Inspection	
General Safety Information.....	6
Warranty Statement.....	6
System and Components.....	7
Installation	
Unit Cooler Installation.....	8
Placement.....	9
Condensate Drain Lines.....	9
Condensing Unit Installation	
Space & Location Requirements.....	10
Rigging & Mounting.....	11
Field Piping Guidelines.....	12-24
Optional Controls.....	25-26
System Wiring.....	27-39
Operation	
Hot Gas Unit Cooler Typical Factory Piping.....	40
Hot Gas Condensing Unit Typical Factory Piping.....	41
Refrigeration Operation.....	42-43
Defrost Operation.....	44-47
Evacuation & Leak Detection.....	48
Check Out & Start-Up.....	49
Program Review.....	50-51
Monitoring & Reviewing Operation Values.....	52
Error and Alarm Details.....	53
Refrigerant Charging.....	54-57
Operational Check Out.....	58
Refrigeration Oils.....	59
Troubleshooting.....	60-62
Preventive Maintenance.....	63-64
InterLink Service Parts.....	65-66
Service Record.....	67
Factory Default Settings.....	68-75
Mohave Control Board Comparison.....	76
Electronic Pressure Regulator Comparison.....	77
Modbus Definitions.....	78-81

Controller Quick Reference Guide

The Mohave™ Hot Gas Controller is located inside the condensing unit electrical panel. The Service Switch is adjacent to the controller on the side of the enclosure.

Control Buttons

Program Review: Review or Change the Program Settings

Enter: Accepts changes into memory

Monitor: View Current Operating Conditions of the System

Reset Time: Resets the time clocks of the microprocessor to 0.

Clear/Test: Clear ignores program selections prior to pressing Enter and terminates Service Mode. Test causes the system to cycle through all of the outputs for troubleshooting.

Select Knob: Used for Cycling through Monitoring and Programming Parameters.

Force Service: Press this button twice to cause the system to pump down and remain off until the Clear button is pressed.

Force Defrost: System will pump down and begin a defrost cycle. This will not effect the normally scheduled defrosts.

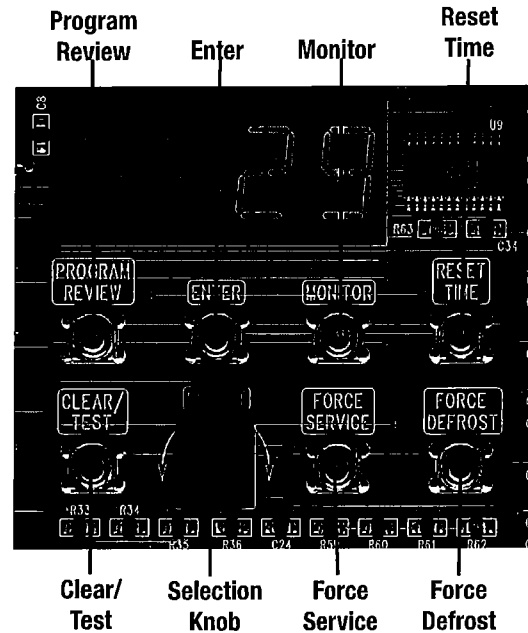

Service Switch

This toggle switch may be placed in the "on" position to force the system into Service Mode. The compressor will pump down and shut off. The evaporator fans will de-energize. The system can be left in service.

Operating Modes

MODE	DESCRIPTION
OFF	Compressor Off
COOL	Compressor On in Cooling Normal Cooling Operation
PMPD	System in Pump Down Mode
SERV	Service Mode, System is Off
DEL Y	Time Delay
DEF 1	Defrost Stage 1 Pre-Defrost or ByPass Mode
DEF 2	Defrost Stage 2 Defrost Mode
DEF 3	Defrost Stage 3 Post Defrost Equalization or Drain Down Mode
FREZ	Refreeze Mode
TEST	Test Mode
SERV	Service Mode
EVAC	Evacuation Mode

Controller Quick Reference Guide

Program Review Menu

DISPLAY	DESCRIPTION	FACTORY DEFAULT
ELKH	Set the Time of Day clock hour value	None
ELKM	Set the Time of Day clock minute value	None
°F °C	Set Fahrenheit or Celsius temperature units (°F or °C)	°F
1224	Set Time display method (12 hr. or 24 hr.)	12 hr
ALRT	Set the Alarm Time (2 to 120 minutes)	20 min
RTDF*	Defrost Schedule based on Compressor Runtime	OFF
DF01	Set Defrost 1 starting time (12:00 am to 12:00 pm in 30 minute increments)	12:00AM
DF02	Set Defrost 2 starting time	6:00AM
DF03	Set Defrost 3 starting time	12:00PM
DF04	Set Defrost 4 starting time	6:00PM
DF05 - DF 12	Set Defrost XX starting time	--- ---
APPL**	Set Application type (Med., Low)	Med Temp
REFR	Set Refrigerant type (R-22, R-404A, R-507, R-407A, R-407C, R-407F, R-448A and R-449A)"	R-404A
MDL	Set Model Number	1502
XPRT	Expert Mode (To Access Additional Program Parameters (On, Off)	Off

(See Program Review Section for additional information)

*Software V1.04 and higher.

**Menu re-ordered Software V2.05 and higher

Monitor Display Menu

DISPLAY	DESCRIPTION
VALP	Defrost Regulator Valve percent of opening (0 to 100%)
SUPH	Superheat (°F.) measured at inlet of Suction Accumulator
SUCT	Suction Temperature (°F.) at inlet of Suction Accumulator
SUCP	Suction Pressure (PSIG/"HG) at inlet of Suction Accumulator
SSUC	Saturated Suction Temperature (°F.) at inlet of Suction Accumulator
LIDP	Liquid Pressure (PSIG) measured between Receiver and Condenser
AMBT	Ambient Air Temperature (°F.) measured entering condenser coil
AUXT	Auxiliary Probe Temperature (°F.)
E1DT	Evaporator 1 Defrost Sensor Termination Temp (°F.) at outlet of Evaporator 1
E2DT	Evaporator 2 Defrost Sensor Termination Temp (°F.) at outlet of Evaporator 2
ACIN	Control Board voltage (24VAC nominal)
TMMS	Current time minutes and seconds
TMHM	Current time hours and minutes
CCYC	Compressor Cycles since Midnight
RnTM	Compressor Run Time since Midnight
DFTM	Duration Time of Last Defrost
ETLD	Elapsed Time since last Defrost (HH.MM)
RTL D	Run Time since last Defrost (HH.MM)
VERS	Software version

Controller Quick Reference Guide

Forced Output Menu

DISPLAY	DESCRIPTION
<i>EVPF</i>	Evaporator Fan Contactor
<i>LIQS</i>	Liquid Line Solenoid
<i>EVPH</i>	Evaporator Pan Heater
<i>FAN4</i>	Condenser Fan 4 Contactor
<i>FAN3</i>	Condenser Fan 3 Contactor
<i>FAN2</i>	Condenser Fan 2 Contactor
<i>FAN1</i>	Condenser Fan 1 Contactor
<i>COMP</i>	Compressor Contactor
<i>BYPV</i>	Bypass Solenoid
<i>SUCS</i>	Suction Stop Solenoid
<i>DEFS</i>	Defrost Solenoid
<i>3WAY</i>	3-Way Valve Solenoid
<i>ALRM</i>	Alarm Contacts
<i>VALS</i>	Regulator Valve Control
<i>EVRC</i>	Activate all Solenoids, Open the Pressure Regulator Valve

System Alarms

DISPLAY	DESCRIPTION
<i>Alr1</i>	Persistent input sensor/transducer failure
<i>Alr2</i>	Combines Err4 and Err8, system off
<i>Alr3</i>	Repeated Safety Circuit Open condition
<i>Alr4</i>	Prolonged Cooling Startup Failure

System Errors

DISPLAY	DESCRIPTION
<i>Err1</i>	Suction temperature sensor open or short
<i>Err2</i>	Ambient temp sensor open or short
<i>Err3</i>	Auxiliary temp sensor open or short
<i>Err4</i>	Suction Pressure sensor open or short
<i>Err5</i>	Liquid Pressure sensor open or short
<i>Err6</i>	Evap 1 defrost temp sensor open or short
<i>Err7</i>	Evap 2 defrost temp sensor open or short
<i>Err8</i>	Redundant Low Pressure Switch Malfunction detected
<i>Err9</i>	Safety Circuit interruption during normal operation
<i>Er10</i>	Prolonged Low Suction Pressure during cooling
<i>Er11</i>	Low Suction Pressure startup failure
<i>Er12</i>	High Suction Pressure startup failure
<i>Er13</i>	Post Defrost pump down error

General Safety Information

1. Installation and maintenance to be performed only by qualified personnel who are familiar with this type of equipment.
2. Some units are pressurized with dry air or inert gas. All units must be evacuated before charging the system with refrigerant.
3. Make sure that all field wiring conforms to the requirements of the equipment and all applicable national and local codes.
4. Avoid contact with sharp edges and coil surfaces. They are a potential injury hazard.
5. Make sure all power sources are disconnected before any service work is done on units.

WARNING: Refrigerant can be harmful if it is inhaled. Refrigerant must be used and recovered responsibly. Failure to follow this warning may result in personal injury or death.

Inspection

Responsibility should be assigned to a dependable individual at the job site to receive material. Each shipment should be carefully checked against the bill of lading. The shipping receipt should not be signed until all items listed on the bill of lading have been accounted. Check carefully for concealed damage. Any shortage or damages should be reported to the delivering carrier. Damaged material becomes the delivering carrier's responsibility, and should not be returned to the manufacturer unless prior approval is given to do so. When uncrating, care should be taken to prevent damage. Heavy equipment should be left on its shipping base until it has been moved to the final location. Check the serial tag information with invoice. Report any discrepancies to your Heatcraft Refrigeration Products Sales Representative.

Warranty Statement

Seller warrants to its direct purchasers that products, including Service Parts, manufactured by SELLER shall be of a merchantable quality, free of defects in material or workmanship, under normal use and service for a period of one **(1) year from date of original installation, or eighteen (18) months from date of shipment** by SELLER, whichever first occurs. Any product covered by this order found to Seller's satisfaction to be defective upon examination at Seller's factory will at SELLER's option, be repaired or replaced and returned to Buyer via lowest common carrier, or SELLER may at its option grant Buyer a credit for the purchase price of the defective article. Upon return of a defective product to SELLER's plant, freight prepaid, by Buyer, correction of such defect by repair or replacement, and return freight via lowest common carrier, shall constitute full performance by SELLER of its obligations hereunder.

SELLER shall have no liability for expenses incurred for repairs made by Buyer except by prior, written authorization. Every claim on account of breach of warranty shall be made to SELLER in writing within the warranty period specified above – otherwise such claim shall be deemed waived. Seller shall have no warranty obligation whatsoever if its products have been subjected to alteration, misuse, negligence, free chemicals in system, corrosive atmosphere, accident, or if operation is contrary to SELLER's or manufacturer's recommendations, or if the serial number has been altered, defaced, or removed.

MOTOR COMPRESSORS:

Motor compressors furnished by SELLER are subject to the standard warranty terms set forth above, except that motor compressor replacements or exchanges shall be made through the nearest authorized wholesaler of the motor compressor manufacturer (not at SELLER's factory) and no freight shall be allowed for transportation of the motor compressor to and from the wholesaler. The replacement motor compressor shall be identical to the model of the motor compressor being replaced. Additional charges which may be incurred throughout the substitution of other than identical replacements are not covered by this warranty. An optional, non assignable, four (4) year extended compressor warranty may be purchased within the boundaries of the United States of America, its territories and possessions, and Canada. With this extended compressor warranty, replacements are administered by an authorized compressor distributor only. Replacements within the first year of the warranty area available through the distributor; the second through fifth years,

the purchaser must submit a proof-of-purchase of a compressor and supply it to Heatcraft Refrigeration Products Warranty Claims for reimbursement. Seller makes no express warranties except as noted above. All implied warranties are limited to the duration of the Express Warranty. Liability for incidental and consequential damages is excluded.

The forgoing is in lieu of all other warranties, express or implied, notwithstanding the provisions of the uniform commercial code, the Magnuson-Moss Warranty - Federal Trade Commission Improvement Act, or any other statutory or common law, federal or state.

SELLER makes no warranty, express or implied, of fitness for any particular purpose, or of any nature whatsoever, with respect to products manufactures or sold by seller hereunder, except as specifically set forth above and on the face hereof. It is expressly understood and agreed that SELLER shall not be liable to buyer, or any customer of buyer, for direct or indirect, special, incidental, consequential or penal damages, or for any expenses incurred by reason of the use or misuse by buyer or third parties of said products. To the extent said products may be considered "consumer products," As defined in Sec. 101 of the Magnuson-Moss Warranty - Federal Trade Commission Improvement Act, SELLER makes no warranty of any kind, express or implied, to "consumers," except as specifically set forth above and on the face hereof.

The following conditions should be adhered to when installing this unit to maintain the manufacturers warranty:

- (a) System piping must be in accordance with good refrigeration practices.
- (b) **Inert gas must be charged into the piping during brazing.**
- (c) The power supply to the unit must meet the following conditions:
 - A. Three phase voltages must be +/- 10% of nameplate ratings. Single phase must be within +10% or -5% of nameplate ratings.
 - B. Phase imbalance cannot exceed 2%.
- (d) All control and safety switch circuits must be properly connected according to the wiring diagram.
- (e) The factory installed wiring must not be changed without written factory approval.
- (f) All equipment is installed in accordance with Heatcraft Refrigeration Products specified minimum clearances.
- (g) Devices not provided by Heatcraft shall not be connected to the Mohave controller without written factory approval
- (h) Refrigerant line runs between condensing unit and evaporator(s) shall not exceed 200 ft without written factory approval

System and Components

Condensing Unit (Vertical Air Discharge Design)

Standard Features:

- Electronic Hot Gas Defrost Controller includes Defrost Initiation and Termination Control, Pressure Fan Cycling for Head Pressure Control, Ambient Fan Cycling Option, Anti-Short Cycling Protection, and Low Pressure Control
- Electronic Pressure Regulator for Defrost Control
- Suction Accumulator
- High Pressure and Redundant Low Pressure Control
- Oil Pressure Safety Control
- High Efficiency Copeland Discus Compressors with POE oil
- Thermally Protected Permanently Lubricated Ball Bearing Condenser Fan Motors
- Electrical Controls located in easily accessible control box with a hinged cover
- Receivers are sized for sufficient pump down capacity with inlet and outlet service valves
- Cabinet is constructed from painted galvanized steel
- Convenient Access Panels for easy servicing to internal components
- Suction and Discharge Vibration Eliminators
- Separate Sub-cooling Circuit.
- Replaceable Liquid Line Filter Drier
- Replaceable Core Suction Filter
- Sight Glass
- Compressor Head Fan on L6 Models
- MODBUS RS-485 (Inherent on control board)

Optional Features:

- Head Pressure Valves (ORI/ORD)
- Oil Separator
- Insulated and Heated Receiver
- Fused Disconnect Switch
- Non-fused Disconnect Switch
- Coated Condenser Coils for protection against harsh environments (Consult factory)
- Phase Loss Monitor
- Mounted Evaporator Control Contactors
- Remote Monitoring (RRC) Wireless Transmitter
- Variable Frequency Drive Package for Condenser Motors (Consult factory)
- Demand Cooling (Required for R-407A, R-407F, R-448A, and R-449A L6 models)

Evaporators

(Medium Profile & High Profile Unit Coolers)

Standard Features:

- All Components are factory installed and wired
- Power Supply Independent from Condensing Unit
- Mounted Fan Control Contactors and Drain Pan Heater Contactors if specified
- Four or Six Fins Per Inch Models
- Mounted TXV and Distributor Nozzle
- Mounted Check Valves
- Mounted Liquid Line Solenoid
- Suction P-Trap
- Thermally Protected Permanently Lubricated Evaporator Fan Motors
- Mounted Electric Drain Pan Heaters
- Insulated Drain Pan (Low Temperature Systems)

Optional Features:

- Mounted Hot Gas Drain Pan Loop
- Evaporator Powered from Condensing Unit

Unit Cooler Installation

Unit Cooler Installation

Most evaporators can be mounted with rod hangers, lag screws, or bolts. Use 5/16" bolt and washers or rod for up to 250 pounds, 3/8" for up to 600 pounds and 5/8" for over 600 pounds. Care should be taken to mount the units level so that condensate drains properly. Adequate support must be provided to hold the weight of the unit.

When using rod hangers, allow adequate space between the top of the unit and the ceiling for cleaning. To comply with NSF Standard 7, the area above the unit cooler must be sealed or exposed in such a way to facilitate hand cleaning without the use of tools. When lagging or bolting the unit flush to the ceiling, seal the joint between the

top and the ceiling with an NSF listed sealant and ends of open hanger channels must be sealed to prevent accumulation of foreign matter.

When locating unit coolers in a cooler or freezer, refer to Figure 1-2 for guidelines.

Figure 1. Large Coolers and Freezers Placement.

NOTE: *Always avoid placement of Unit Coolers directly above doors and door openings.*

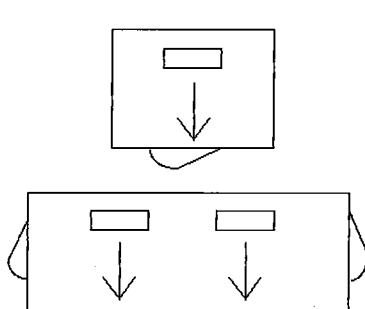

Where one wall evaporator mounting is satisfactory.

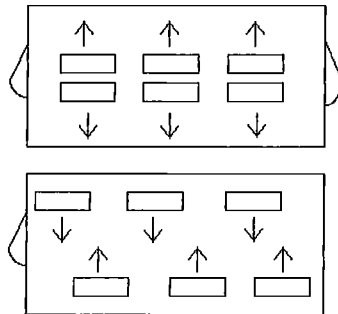

Cooler or Freezers where one wall will not accommodate all required evaporators or where air throw distance must be considered.

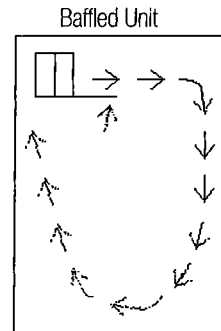

Allow sufficient space between rear of Unit Cooler and wall to permit free return of air.

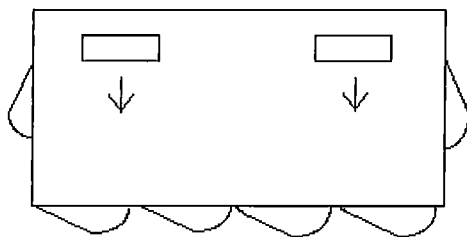

Cooler or Freezer with Glass Display Doors

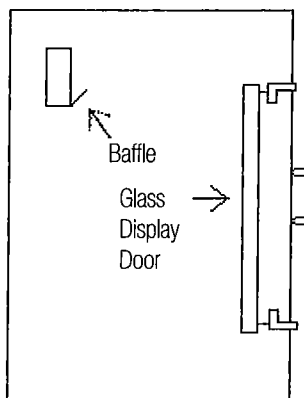

Elevation view of glass display door cooler or freezer. Be sure air discharge blows above, not directly at doors. Provide baffle if door extends above blower level.

Unit Cooler Installation & Condensate Lines

Unit Coolers (continued)

Recommended Unit Cooler Placement

Some general rules for evaporator placement which must be followed are:

1. The air pattern must cover the entire room
2. **NEVER** locate evaporators over doors
3. Location of aisles, racks, etc. must be known
4. Location relative to compressors for minimum pipe runs
5. Location of condensate drains for minimum run.

The size and shape of the storage will generally determine the type and number of evaporators to be used and their location. The following are some typical examples:

Minimum Unit Clearances

Figure 2. Medium Profile and Large Unit Coolers

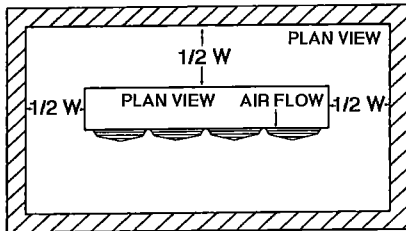

One evaporator

NOTE:
W = Total width
of evaporator
coil surface.

NOTE: Leave space equal to unit height between bottom of unit and product. Do not stack product in front of fans.

Condensate Drain Lines

Either copper or steel drain lines should be used and properly protected from freezing. In running drain lines, provide a minimum 4 inches per foot pitch for proper drainage. Drain lines should be at least as large as the evaporator drain connection. All plumbing connections should be made in accordance with local plumbing codes. All condensate drain lines must be trapped, and run to an open drain. They must never be connected directly to the sewer system. Traps in the drain line must be located in a warm ambient. We recommend a trap on each evaporator drain line prior to any tee connections. Traps located outside, or extensive outside runs of drain line must be wrapped with a drain line heater. The heater should be connected so that it operates continuously. It is recommended that the drain line be insulated to prevent heat loss. A heat input of 20 watts per linear foot of drain line for 0°F (-18°C) room applications and 30 watts per linear foot for -20°F (-29°C) rooms is satisfactory. In freezers, the evaporator drain pan fitting should be included when heating and insulating the drain line.

Inspect drain pan periodically to insure free drainage of condensate. If drain pan contains standing water, check for proper installation. The drain pan should be cleaned regularly with warm soapy water.

WARNING: All power must be disconnected before cleaning.
Drain pan also serves as cover of hazardous moving parts.
Operation of unit without drain pan constitutes a hazard.

Traps on low temperature units must be outside of refrigerated enclosures. Traps subject to freezing temperatures must be wrapped with heat tape and insulated.

NOTE: Always trap single evaporator system drain lines individually to prevent humidity migration.

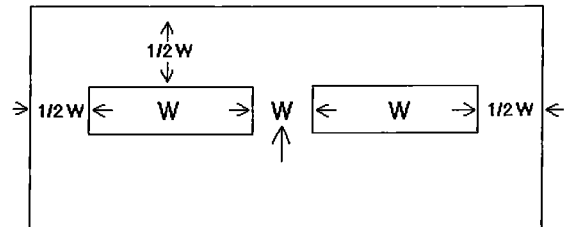

Two evaporators

Condensate Drain Lines

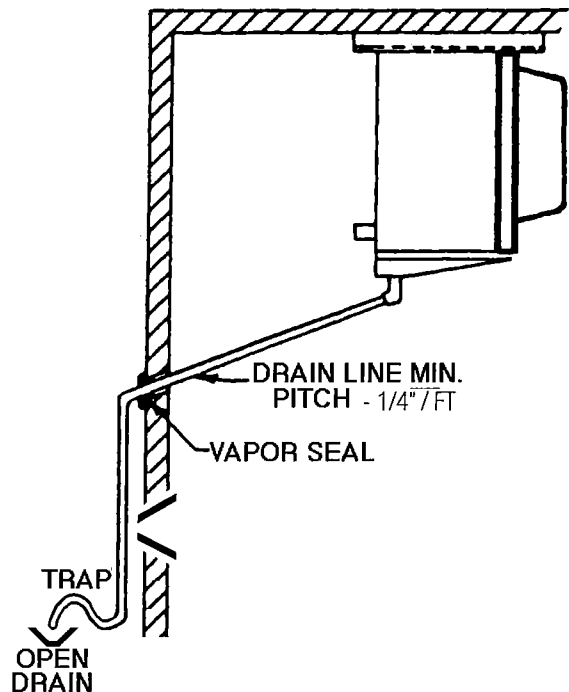

Condensing Unit Installation

Space & Location Requirements for Air Cooled Condensing Units and Remote Condensers

The most important consideration which must be taken into account when deciding upon the location of air-cooled equipment is the provision for a supply of ambient air to the condenser, and removal of heated air from the condensing unit or remote condenser area. Where this essential requirement is not adhered to, it will result in higher head pressures, which cause poor operation and potential failure of equipment. Units must not be located in the vicinity of steam, hot air or fume exhausts. Corrosive atmospheres require custom designed condensers.

Another consideration which must be taken is that the unit should be mounted away from noise sensitive spaces and must have adequate support to avoid vibration and noise transmission into the building. Units should be mounted over corridors, utility areas, rest rooms and other auxiliary areas where high levels of sound are not an important factor. Sound and structural consultants should be retained for recommendations.

Space and Location Requirements for Condensing Units and Remote Condensers

Walls or Obstructions

The unit should be located so that air may circulate freely and not be recirculated. For proper air flow and access all sides of the unit should be a minimum of "W" away from any wall or obstruction. It is preferred that this distance be increased whenever possible. Care should be taken to see that ample room is left for maintenance work through access doors and panels. Overhead obstructions are not permitted. When the unit is in an area where it is enclosed by three walls the unit must be installed as indicated for units in a pit.

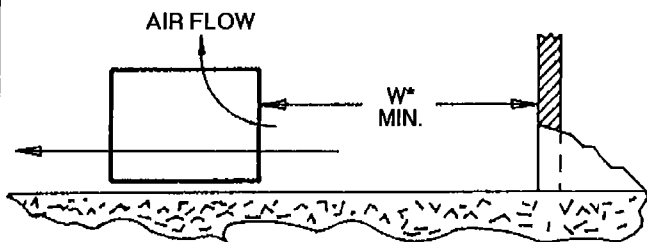

Multiple Units

For units placed side by side, the minimum distance between units is the width of the largest unit. If units are placed end to end, the minimum distance between units is 4 feet.

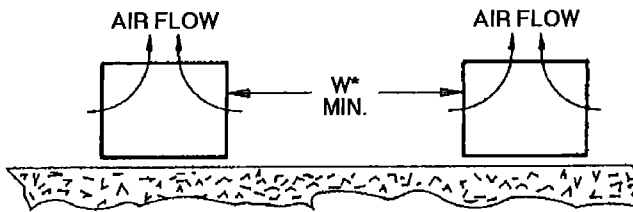

Units in Pits

The top of the unit should be level with the top of the pit, and side distance increased to "2W".

If the top of the unit is not level with the top of pit, discharge cones or stacks must be used to raise discharge air to the top of the pit. This is a minimum requirement.

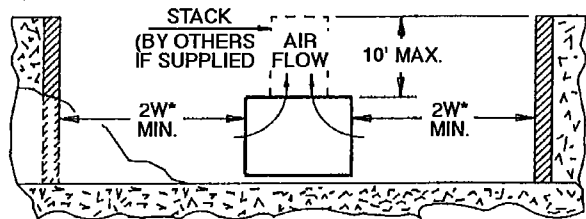

Decorative Fences

Fences must have 50% free area, with 1 foot undercut, a "W" minimum clearance, and must not exceed the top of unit. If these requirements are not met, unit must be installed as indicated for "Units in pits".

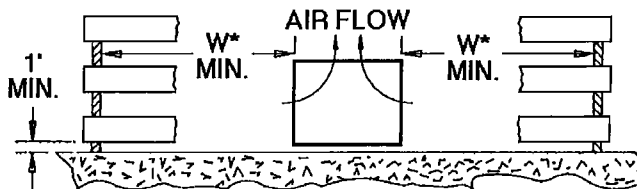

Walls or Obstructions for Horizontal Air Flow

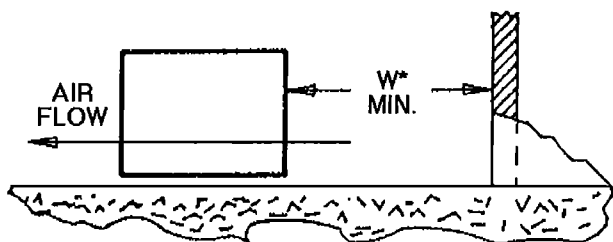

Multiple Units with Horizontal Air Flow

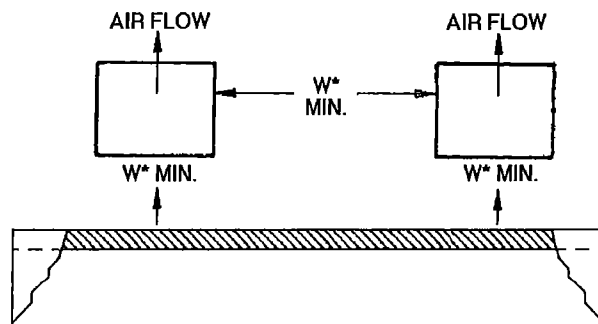

* "W" = Total width of the condensing unit or condenser.

Condensing Unit Installation

Condensing Unit Rigging and Mounting

Rigging holes are provided on all units. Caution should be exercised when moving these units. To prevent damage to the unit housing during rigging, cables or chains used must be held apart by spacer bars. The mounting platform or base should be level and located so as to permit free access of supply air.

Ground Mounting

Concrete slab raised six inches above ground level provides a suitable base. Raising the base above ground level provides some protection from ground water and wind blown matter. Before tightening mounting bolts, recheck level of unit. The unit should in all cases be located with a clear space in all directions that is at a minimum, equal to the height of the unit above the mounting surface. A condensing unit mounted in a corner formed by two walls, may result in discharge air recirculation with resulting loss of capacity.

Roof Mounting

Due to the weight of the units, a structural analysis by a qualified engineer may be required before mounting. Roof mounted units should be installed level on steel channels or an I-beam frame capable of supporting the weight of the unit. Vibration absorbing pads or springs should be installed between the condensing unit legs or frame and the roof mounting assembly.

Access

Provide adequate space at the compressor end of the unit for servicing. Provide adequate space on the connection side to permit service of components.

Figure 3. Spring Mount

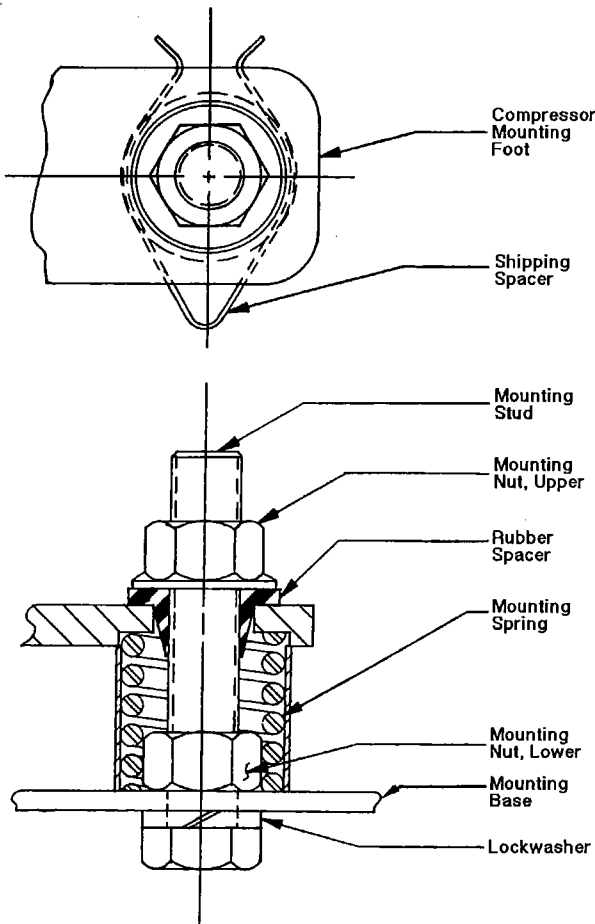

Spring Mounted Compressor

Compressors are secured rigidly to make sure there is no transit damage. Before operating the unit, it is necessary to follow these steps:

- Remove the upper nuts and washers.
- Discard the shipping spacers.
- Install the neoprene spacers. (Spacers located in the electrical panel or tied to compressor.)
- Replace the upper mounting nuts and washers.
- Allow 1/16 inch space between the mounting nut/washer and the neoprene spacer. See Figure 3 below.

Rigid Mounted Compressor

Some products use rigid mounted compressors. Check the compressor mounting bolts to insure they have not vibrated loose during shipment. See Figure 3 and 5 below.

Figure 4. Solid Mount for Mobile or Deep Sump Application.

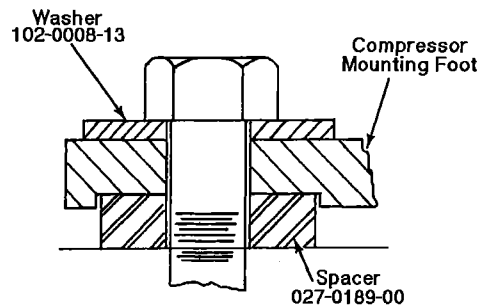
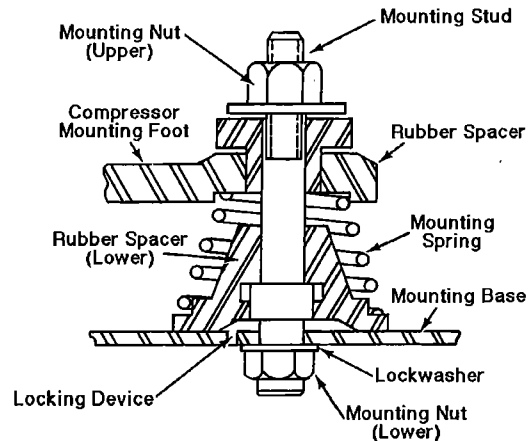

Figure 5. Spring Mount



Mount is shown in properly adjusted position.

Piping

Recommended Refrigerant Piping Practices

The system as supplied by **Heatcraft Refrigeration Products**, was thoroughly cleaned and dehydrated at the factory. Foreign matter may enter the system by way of the evaporator to condensing unit piping. Therefore, care must be used during installation of the piping to prevent entrance of foreign matter.

Install all refrigeration system components in accordance with applicable local and national codes and in conformance with good practice required for the proper operation of the system.

The refrigerant pipe size should be selected from the tables on pages 15-21. The interconnecting pipe size is not necessarily the same size as the stub-out on the condensing unit or the evaporator.

The following procedures should be followed:

- (a) Do not leave dehydrated compressors or filter driers open to the atmosphere.
- (b) Use only refrigeration grade copper tubing, properly sealed against contamination.
- (c) Suction lines should slope 1/4" per 10 feet towards the compressor.
- (d) Suitable P-type oil traps should be located at the base of each suction riser to enhance oil return to the compressor.
- (e) For desired method of superheat measurement, a pressure tap should be installed in each evaporator suction line in the proximity of the expansion valve bulb.
- (f) **When brazing refrigerant lines, an inert gas should be passed through the line at low pressure to prevent scaling and oxidation inside the tubing. Dry nitrogen is preferred.**
- (g) Use only a suitable silver solder alloy on suction and liquid lines.
- (h) Limit the soldering paste or flux to the minimum required to prevent contamination of the solder joint internally. Flux only the male portion of the connection, never the female. After brazing, remove excess flux.
- (i) If isolation valves are installed at the evaporator, full port ball valves should be used.
- (j) Do not install liquid/suction line heat exchangers.

Refrigerant Pipe Support

1. Normally, any straight run of tubing must be supported in at least two locations near each end of the run. Long runs require additional supports. The refrigerant lines should be supported and fastened properly. As a guide, 3/8 to 7/8 should be supported every 5 feet; 1-1/8 and 1-3/8 every 7 feet; and 1-5/8 and 2-1/8 every 9 to 10 feet.
2. When changing directions in a run of tubing, no corner should be left unsupported. Supports should be placed a maximum of 2 feet in each direction from the corner.
3. Piping attached to a vibrating object (such as a compressor or compressor base) must be supported in such a manner that will not restrict the movement of the vibrating object. Rigid mounting will fatigue the copper tubing.
4. Do not use short radius ells. Short radius elbows have points of excessive stress concentration and are subject to breakage at these points.
5. Thoroughly inspect all piping after the equipment is in operation and add supports wherever line vibration is significantly greater than most of the other piping. Extra supports are relatively inexpensive as compared to refrigerant loss.

Example of Pipe Support

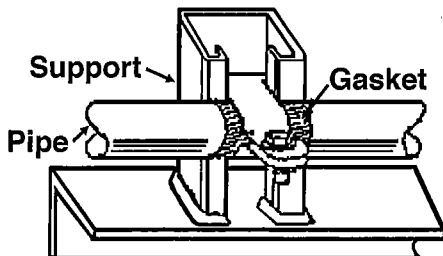

Condensing Unit / Compressor to Wall Support

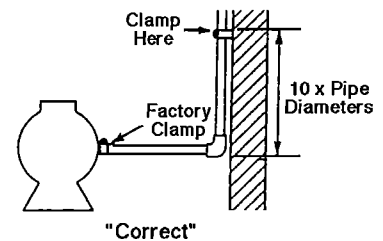
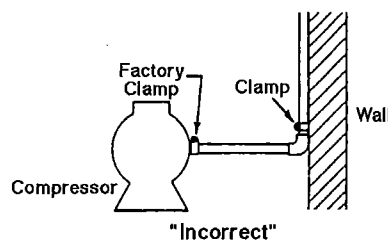

Piping

The following are examples of proper piping layout for typical system configurations

CONDENSING UNIT MOUNTED BELOW TWO EVAPORATORS

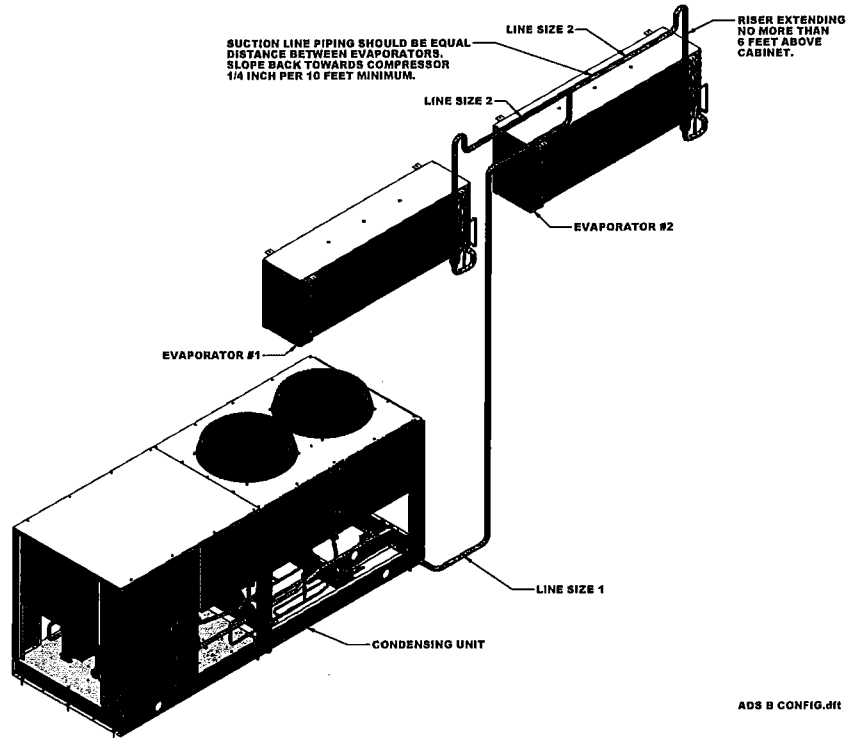

CONDENSING UNIT MOUNTED BELOW EVAPORATOR

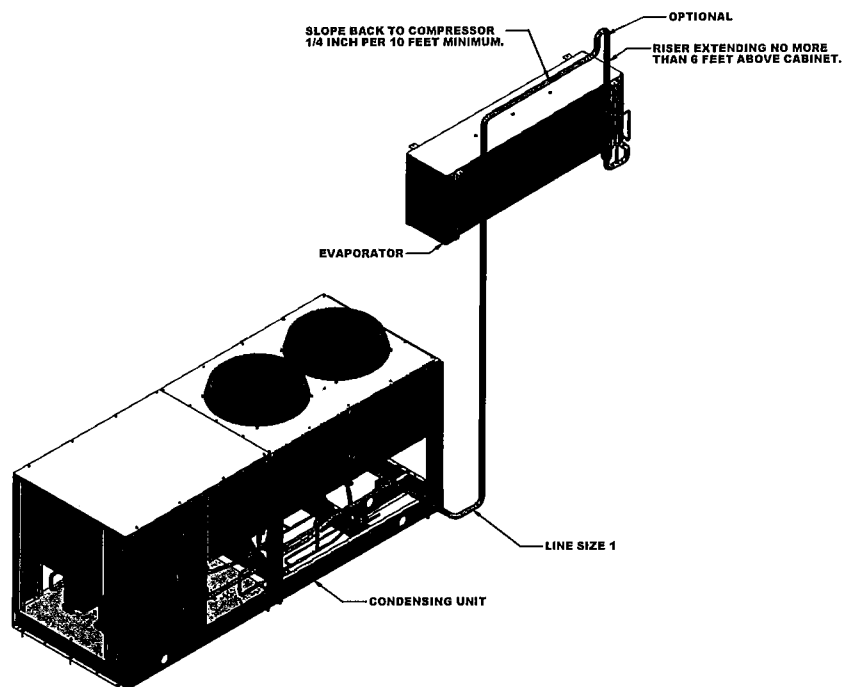

Piping

CONDENSING UNIT MOUNTED ABOVE EVAPORATOR

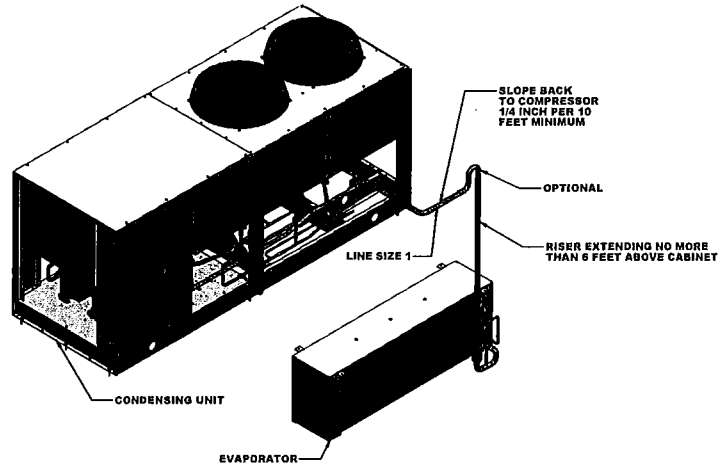

CONDENSING UNIT MOUNTED ABOVE EVAPORATOR HORIZONTAL LINE RUN IN BUILDING

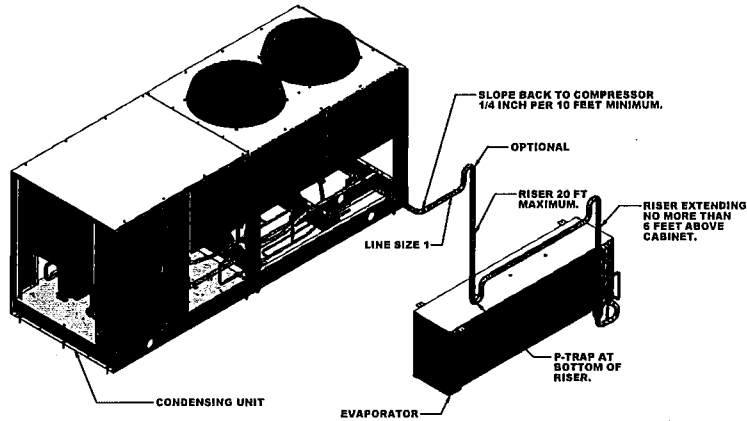

CONDENSING UNIT MOUNTED ABOVE TWO EVAPORATORS

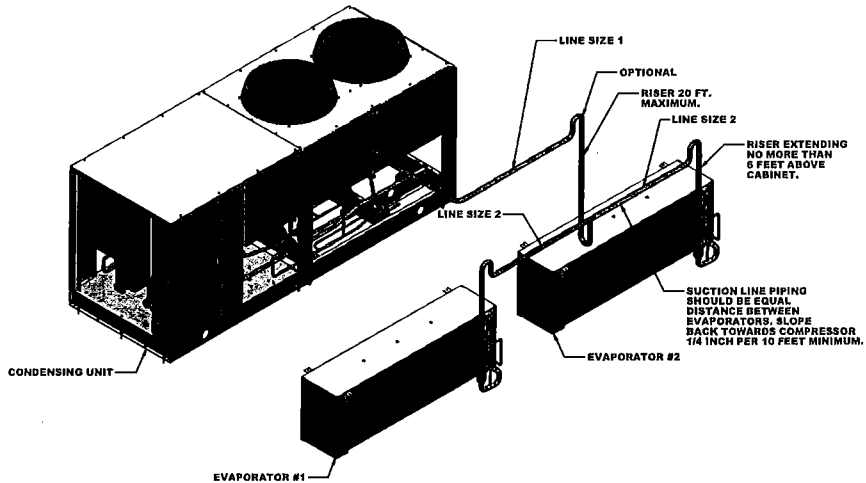

Piping

Unit Cooler Piping

Pipe size example:

Given: **-10°F Freezer** with one system having (2) evaporators

- One condensing unit rated at 24,000 BTUH's @ -20°F SST R404A refrigerant.
- Two evaporators each rated at 12,000 BTUH's @ 10°F TD.
- 75 feet of actual line run between condensing unit to first evaporator and 20 feet of actual line run between the first evaporator and the second evaporator (see figure below).

NOTE: This is a line sizing example. Use diagrams on page 13-14 for piping orientation.

How to figure line sizes:

1. Determine equivalent line run = actual run + valves and fitting allowances.
2. Use Line Sizing Tables on pages 16-21 to size lines.
3. Note any special considerations.

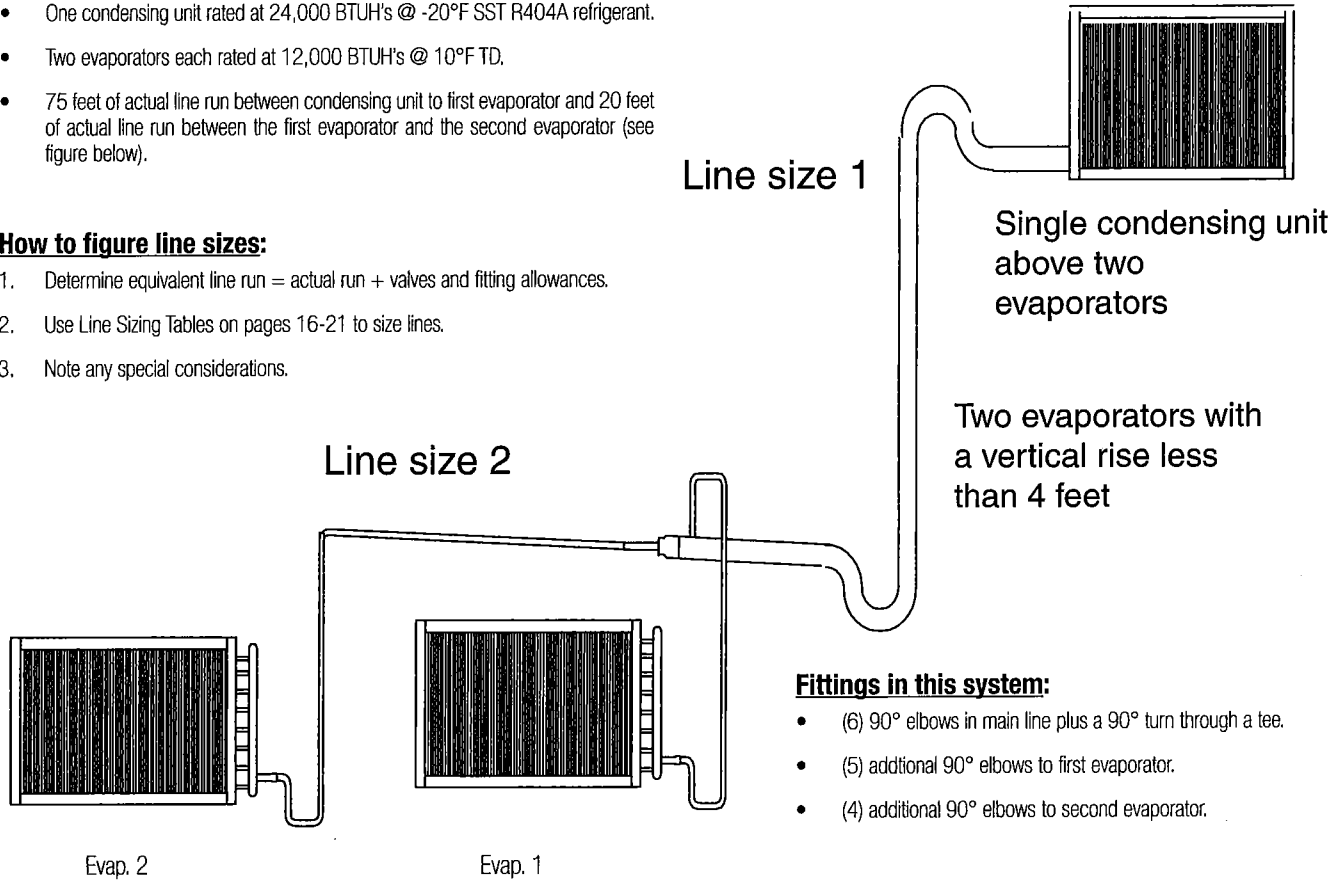

Fittings in this system:

- (6) 90° elbows in main line plus a 90° turn through a tee.
- (5) additional 90° elbows to first evaporator.
- (4) additional 90° elbows to second evaporator.

Determine line size 1 (main line from condensing unit):

1. Main line from the condensing unit to be sized for the total capacity (balance) of the whole system of 24,000 BTUH's (Table 3 and 3A).
2. Refer to 24,000 @75 feet at -20°F SST R404A on the chart. You will find the suction line to be 1 1/8" and 1/2" liquid line.
3. Refer to Table 5A. For every 1 1/8" 90° elbow you must add 3 equivalent feet of pipe and 2 equivalent feet of pipe for each 1 1/8" tee.

Therefore, total equivalent line run =

Actual line run	75 feet
+ (6) 1 1/8" elbows @ 3'	18 feet
+ (1) 1 1/8" tee @ 2'	<u>2 feet</u>
Total equivalent line run	95 feet

4. Refer to Table 3A. For 95 total equivalent feet, the suction line size should be 1 3/8" and the liquid line stays at 1/2" line.

Note: The gray shaded areas on Table 2. For 24,000 BTUH's, the maximum suction riser is 1 1/8" to insure proper oil return and pressure drop from the bottom p-trap to the top p-trap.

Determine line size 2 (evaporators):

1. Line sizing to each evaporator is based on 12,000 BTUH's and equivalent run from condensing unit. First evaporator has an 80 ft. run and the second evaporator has a 95 ft. run.
2. Table 3 indicates 7/8" suction for the first evaporator and Table 3A indicates 1 1/8" suction for the second evaporator.
3. Refer to Table 5A. Each 7/8" 90° elbow adds 2 equivalent feet of pipe. Each 1 1/8" 90° elbow adds 3 equivalent feet and a 90° turn through a 1 1/8" tee adds 6 equivalent feet.

4. Actual line run (evap 1)	80 feet
+ (5) 7/8" elbows @ 2'	10 feet
+ (1) 90° turn through tee @ 6'	<u>6 feet</u>
Total equivalent line run	96 feet
Actual line run (evap 2)	95 feet
+ (4) 1 1/8" elbows @ 3'	<u>12 feet</u>
Total equivalent line run	107 feet

5. Table 3A indicates 1 1/8" suction line and 3/8" liquid line from main line to both evaporators.

Line Sizing

Table 1. Recommended Line Sizes for R-407*

System Capacity BTU/H	SUCTION LINE SIZE																	
	SUCTION TEMPERATURE																	
	+40 °F Equivalent Lengths						+20 °F Equivalent Lengths						+10 °F Equivalent Lengths					
	25'	50'	75'	100'	150'	200'	25'	50'	75'	100'	150'	200'	25'	50'	75'	100'	150'	200'
1,000	3/8	3/8	3/8	3/8	3/8	3/8	3/8	3/8	3/8	3/8	3/8	3/8	3/8	3/8	3/8	3/8	3/8	3/8
3,000	3/8	3/8	3/8	3/8	1/2	1/2	3/8	3/8	3/8	1/2	1/2	1/2	3/8	3/8	1/2	1/2	1/2	1/2
4,000	3/8	3/8	1/2	1/2	1/2	1/2	3/8	1/2	1/2	1/2	5/8	5/8	3/8	1/2	1/2	5/8	5/8	5/8
6,000	3/8	1/2	1/2	1/2	5/8	5/8	1/2	1/2	1/2	5/8	5/8	5/8	1/2	1/2	5/8	5/8	5/8	5/8
9,000	1/2	1/2	5/8	5/8	5/8	5/8	1/2	5/8	5/8	7/8	7/8	7/8	1/2	5/8	5/8	7/8	7/8	7/8
12,000	1/2	5/8	5/8	7/8	7/8	7/8	5/8	5/8	7/8	7/8	7/8	7/8	5/8	7/8	7/8	7/8	7/8	7/8
15,000	5/8	5/8	7/8	7/8	7/8	7/8	5/8	7/8	7/8	7/8	7/8	7/8	5/8	7/8	7/8	7/8	7/8	7/8
18,000	5/8	7/8	7/8	7/8	7/8	7/8	5/8	7/8	7/8	7/8	7/8	7/8	7/8	7/8	7/8	7/8	1 1/8	1 1/8
24,000	5/8	7/8	7/8	7/8	7/8	7/8	7/8	7/8	7/8	7/8	1 1/8	1 1/8	7/8	7/8	7/8	1 1/8	1 1/8	1 1/8
30,000	7/8	7/8	7/8	7/8	1 1/8	1 1/8	7/8	7/8	7/8	1 1/8	1 1/8	1 1/8	7/8	7/8	1 1/8	1 1/8	1 1/8	1 1/8
36,000	7/8	7/8	7/8	1 1/8	1 1/8	1 1/8	7/8	7/8	1 1/8	1 1/8	1 1/8	1 1/8	7/8	1 1/8	1 1/8	1 1/8	1 1/8	1 3/8
42,000	7/8	7/8	1 1/8	1 1/8	1 1/8	1 1/8	7/8	7/8	1 1/8	1 1/8	1 1/8	1 1/8	7/8	1 1/8	1 1/8	1 1/8	1 3/8	1 3/8
48,000	7/8	7/8	1 1/8	1 1/8	1 1/8	1 1/8	7/8	1 1/8	1 1/8	1 1/8	1 3/8	1 3/8	7/8	1 1/8	1 1/8	1 1/8	1 3/8	1 3/8
54,000	7/8	1 1/8	1 1/8	1 1/8	1 1/8	1 3/8	7/8	1 1/8	1 1/8	1 1/8	1 3/8	1 3/8	1 1/8	1 1/8	1 1/8	1 3/8	1 3/8	1 3/8
60,000	7/8	1 1/8	1 1/8	1 1/8	1 3/8	1 3/8	1 1/8	1 1/8	1 1/8	1 3/8	1 3/8	1 3/8	1 1/8	1 1/8	1 1/8	1 3/8	1 3/8	1 3/8
66,000	7/8	1 1/8	1 1/8	1 1/8	1 3/8	1 3/8	1 1/8	1 1/8	1 1/8	1 3/8	1 3/8	1 3/8	1 1/8	1 1/8	1 3/8	1 3/8	1 3/8	1 5/8
72,000	7/8	1 1/8	1 1/8	1 1/8	1 3/8	1 3/8	1 1/8	1 1/8	1 1/8	1 3/8	1 3/8	1 3/8	1 1/8	1 1/8	1 3/8	1 3/8	1 3/8	1 5/8
78,000	7/8	1 1/8	1 1/8	1 3/8	1 3/8	1 3/8	1 1/8	1 1/8	1 1/8	1 3/8	1 3/8	1 5/8	1 1/8	1 1/8	1 3/8	1 3/8	1 5/8	1 5/8
84,000	1 1/8	1 1/8	1 1/8	1 3/8	1 3/8	1 3/8	1 1/8	1 1/8	1 3/8	1 3/8	1 5/8	1 5/8	1 1/8	1 3/8	1 3/8	1 3/8	1 5/8	1 5/8
90,000	1 1/8	1 1/8	1 3/8	1 3/8	1 3/8	1 5/8	1 1/8	1 3/8	1 3/8	1 5/8	1 5/8	1 5/8	1 1/8	1 3/8	1 3/8	1 5/8	1 5/8	1 5/8
120,000	1 1/8	1 3/8	1 3/8	1 5/8	1 5/8	1 5/8	1 3/8	1 3/8	1 5/8	1 5/8	1 5/8	2 1/8	1 3/8	1 5/8	1 5/8	1 5/8	2 1/8	2 1/8
150,000	1 3/8	1 3/8	1 5/8	1 5/8	1 5/8	2 1/8	1 3/8	1 5/8	1 5/8	1 5/8	2 1/8	2 1/8	1 3/8	1 5/8	1 5/8	2 1/8	2 1/8	2 1/8
180,000	1 3/8	1 3/8	1 5/8	1 5/8	2 1/8	2 1/8	1 3/8	1 5/8	1 5/8	2 1/8	2 1/8	2 1/8	1 5/8	2 1/8	2 1/8	2 1/8	2 1/8	2 1/8
210,000	1 3/8	1 5/8	1 5/8	2 1/8	2 1/8	2 1/8	1 5/8	1 5/8	2 1/8	2 1/8	2 1/8	2 1/8	1 5/8	2 1/8	2 1/8	2 1/8	2 1/8	2 5/8
240,000	1 5/8	1 5/8	2 1/8	2 1/8	2 1/8	2 1/8	1 5/8	2 1/8	2 1/8	2 1/8	2 1/8	2 5/8	1 5/8	2 1/8	2 1/8	2 1/8	2 5/8	2 5/8
300,000	1 5/8	2 1/8	2 1/8	2 1/8	2 1/8	2 5/8	1 5/8	2 1/8	2 1/8	2 1/8	2 5/8	2 5/8	2 1/8	2 1/8	2 1/8	2 5/8	2 5/8	2 5/8
360,000	1 5/8	2 1/8	2 1/8	2 1/8	2 5/8	2 5/8	2 1/8	2 1/8	2 1/8	2 5/8	2 5/8	2 5/8	2 1/8	2 1/8	2 5/8	2 5/8	2 5/8	2 5/8
480,000	2 1/8	2 1/8	2 1/8	2 5/8	2 5/8	2 5/8	2 1/8	2 5/8	2 5/8	2 5/8	3 1/8	3 1/8	2 1/8	2 5/8	2 5/8	3 1/8	3 1/8	3 1/8
600,000	2 1/8	2 5/8	2 5/8	2 5/8	3 1/8	3 1/8	2 5/8	2 5/8	2 5/8	3 1/8	3 1/8	3 1/8	2 1/8	2 5/8	3 1/8	3 1/8	3 1/8	3 5/8

*** NOTES:**

1. Sizes that are highlighted indicate maximum suction line sizes that should be used for risers. Riser size should not exceed horizontal size. Properly placed suction traps must also be used for adequate oil return. All sizes shown are for O.D. Type L copper tubing.
2. Suction line sizes selected at pressure drop equivalent to 2°F. Reduce estimate of system capacity accordingly.
3. If system load drops below 40% of design, consideration to installing double suction risers should be made.
4. R407A, R407C, R407F

Line Sizing

Table 1A. Recommended Line Sizes for R-407 (cont.)*

LIQUID LINE SIZE						System Capacity BTU/H
Receiver to Expansion Valve						
25'	50'	75'	100'	150'	200'	
3/8	3/8	3/8	3/8	3/8	3/8	1,000
3/8	3/8	3/8	3/8	3/8	3/8	3,000
3/8	3/8	3/8	3/8	3/8	3/8	4,000
3/8	3/8	3/8	3/8	3/8	3/8	6,000
3/8	3/8	3/8	3/8	3/8	3/8	9,000
3/8	3/8	3/8	3/8	3/8	3/8	12,000
3/8	3/8	3/8	3/8	3/8	3/8	15,000
3/8	3/8	3/8	3/8	1/2	1/2	18,000
3/8	3/8	3/8	1/2	1/2	1/2	24,000
3/8	1/2	1/2	1/2	1/2	5/8	30,000
3/8	1/2	1/2	1/2	5/8	5/8	36,000
3/8	1/2	1/2	1/2	5/8	5/8	42,000
1/2	1/2	1/2	5/8	5/8	5/8	48,000
1/2	1/2	1/2	5/8	5/8	5/8	54,000
1/2	1/2	5/8	5/8	5/8	5/8	60,000
1/2	1/2	5/8	5/8	5/8	7/8	66,000
1/2	5/8	5/8	5/8	5/8	7/8	72,000
1/2	5/8	5/8	5/8	7/8	7/8	78,000
1/2	5/8	5/8	5/8	7/8	7/8	84,000
1/2	5/8	5/8	7/8	7/8	7/8	90,000
5/8	5/8	7/8	7/8	7/8	7/8	120,000
5/8	7/8	7/8	7/8	7/8	7/8	150,000
7/8	7/8	7/8	7/8	1 1/8	1 1/8	180,000
7/8	7/8	7/8	7/8	1 1/8	1 1/8	210,000
7/8	7/8	7/8	1 1/8	1 1/8	1 1/8	240,000
7/8	7/8	7/8	1 1/8	1 1/8	1 1/8	300,000
7/8	1 1/8	1 1/8	1 1/8	1 1/8	1 3/8	360,000
7/8	1 1/8	1 1/8	1 3/8	1 3/8	1 3/8	480,000
1 1/8	1 1/8	1 3/8	1 3/8	1 3/8	1 3/8	600,000

*** NOTES:**

1. All sizes shown are for O.D. Type L copper tubing.

Line Sizing

Table 2. Recommended Line Sizes for R-448A/R-449A

System Capacity BTU/H	SUCTION LINE SIZE																	
	SUCTION TEMPERATURE																	
	+20 °F Equivalent Lengths						+10 °F Equivalent Lengths						-10 °F Equivalent Lengths					
	25'	50'	75'	100'	150'	200'	25'	50'	75'	100'	150'	200'	25'	50'	75'	100'	150'	200'
1,000	3/8	3/8	3/8	3/8	3/8	3/8	3/8	3/8	3/8	3/8	3/8	1/2	3/8	3/8	3/8	1/2	1/2	1/2
3,000	3/8	3/8	1/2	1/2	1/2	5/8	3/8	1/2	1/2	1/2	5/8	5/8	1/2	1/2	5/8	5/8	5/8	7/8
4,000	3/8	1/2	1/2	1/2	5/8	5/8	1/2	1/2	1/2	5/8	5/8	7/8	1/2	5/8	5/8	5/8	7/8	7/8
6,000	1/2	1/2	5/8	5/8	7/8	7/8	1/2	1/2	5/8	5/8	7/8	7/8	1/2	5/8	5/8	7/8	7/8	7/8
9,000	5/8	5/8	7/8	7/8	7/8	7/8	5/8	5/8	7/8	7/8	7/8	7/8	5/8	7/8	7/8	7/8	7/8	1 1/8
12,000	5/8	7/8	7/8	7/8	7/8	7/8	5/8	7/8	7/8	7/8	7/8	1 1/8	7/8	7/8	7/8	7/8	1 1/8	1 1/8
15,000	5/8	7/8	7/8	7/8	7/8	1 1/8	7/8	7/8	7/8	7/8	1 1/8	1 1/8	7/8	7/8	7/8	1 1/8	1 1/8	1 1/8
18,000	7/8	7/8	7/8	7/8	1 1/8	1 1/8	7/8	7/8	7/8	1 1/8	1 1/8	1 1/8	7/8	7/8	1 1/8	1 1/8	1 1/8	1 3/8
24,000	7/8	7/8	7/8	1 1/8	1 1/8	1 1/8	7/8	1 1/8	1 1/8	1 1/8	1 1/8	1 3/8	7/8	1 1/8	1 1/8	1 1/8	1 3/8	1 3/8
30,000	7/8	7/8	1 1/8	1 1/8	1 1/8	1 3/8	7/8	1 1/8	1 1/8	1 1/8	1 3/8	1 3/8	1 1/8	1 1/8	1 1/8	1 3/8	1 3/8	1 3/8
36,000	7/8	1 1/8	1 1/8	1 1/8	1 3/8	1 3/8	1 1/8	1 1/8	1 1/8	1 3/8	1 3/8	1 3/8	1 1/8	1 1/8	1 3/8	1 3/8	1 3/8	1 5/8
42,000	1 1/8	1 1/8	1 1/8	1 3/8	1 3/8	1 3/8	1 1/8	1 1/8	1 3/8	1 3/8	1 3/8	1 5/8	1 1/8	1 3/8	1 3/8	1 3/8	1 5/8	1 5/8
48,000	1 1/8	1 1/8	1 3/8	1 3/8	1 3/8	1 3/8	1 1/8	1 1/8	1 3/8	1 3/8	1 5/8	1 5/8	1 1/8	1 3/8	1 3/8	1 3/8	1 5/8	1 5/8
54,000	1 1/8	1 1/8	1 3/8	1 3/8	1 3/8	1 5/8	1 1/8	1 3/8	1 3/8	1 3/8	1 5/8	1 5/8	1 3/8	1 3/8	1 3/8	1 5/8	1 5/8	1 5/8
60,000	1 1/8	1 1/8	1 3/8	1 3/8	1 5/8	1 5/8	1 1/8	1 3/8	1 3/8	1 5/8	1 5/8	1 5/8	1 3/8	1 3/8	1 5/8	1 5/8	1 5/8	2 1/8
66,000	1 1/8	1 3/8	1 3/8	1 3/8	1 5/8	1 5/8	1 1/8	1 3/8	1 3/8	1 5/8	1 5/8	1 5/8	1 3/8	1 5/8	1 5/8	1 5/8	1 5/8	1 5/8
72,000	1 1/8	1 3/8	1 3/8	1 5/8	1 5/8	1 5/8	1 1/8	1 3/8	1 5/8	1 5/8	1 5/8	1 5/8	1 3/8	1 5/8	1 5/8	1 5/8	1 5/8	1 5/8
78,000	1 1/8	1 3/8	1 3/8	1 5/8	1 5/8	2 1/8	1 3/8	1 3/8	1 5/8	1 5/8	1 5/8	2 1/8	1 3/8	1 5/8	1 5/8	1 5/8	1 5/8	2 1/8
84,000	1 1/8	1 3/8	1 5/8	1 5/8	1 5/8	2 1/8	1 3/8	1 3/8	1 5/8	1 5/8	2 1/8	2 1/8	1 3/8	1 5/8	1 5/8	1 5/8	2 1/8	2 1/8
90,000	1 3/8	1 3/8	1 5/8	1 5/8	2 1/8	2 1/8	1 3/8	1 5/8	1 5/8	1 5/8	2 1/8	2 1/8	1 5/8	1 5/8	1 5/8	2 1/8	2 1/8	2 5/8
120,000	1 3/8	1 5/8	1 5/8	2 1/8	2 1/8	2 1/8	1 3/8	1 5/8	2 1/8	2 1/8	2 1/8	2 1/8	1 5/8	2 1/8	2 1/8	2 1/8	2 5/8	2 5/8
150,000	1 5/8	1 5/8	2 1/8	2 1/8	2 1/8	2 1/8	1 5/8	2 1/8	2 1/8	2 1/8	2 1/8	2 5/8	2 1/8	2 1/8	2 1/8	2 5/8	2 5/8	2 5/8
180,000	1 5/8	2 1/8	2 1/8	2 1/8	2 1/8	2 5/8	1 5/8	2 1/8	2 1/8	2 1/8	2 5/8	2 5/8	2 1/8	2 1/8	2 5/8	2 5/8	2 5/8	3 1/8
210,000	1 5/8	2 1/8	2 1/8	2 1/8	2 5/8	2 5/8	2 1/8	2 1/8	2 1/8	2 5/8	2 5/8	2 5/8	2 1/8	2 1/8	2 5/8	2 5/8	3 1/8	3 1/8
240,000	1 5/8	2 1/8	2 1/8	2 1/8	2 5/8	2 5/8	2 1/8	2 1/8	2 5/8	2 5/8	2 5/8	2 5/8	2 1/8	2 5/8	2 5/8	2 5/8	3 1/8	3 1/8
300,000	2 1/8	2 1/8	2 5/8	2 5/8	2 5/8	3 1/8	2 1/8	2 5/8	2 5/8	2 5/8	3 1/8	3 1/8	2 5/8	2 5/8	2 5/8	3 1/8	3 1/8	3 5/8
360,000	2 1/8	2 1/8	2 5/8	2 5/8	3 1/8	3 1/8	2 1/8	2 5/8	2 5/8	2 5/8	3 1/8	3 1/8	2 5/8	2 5/8	3 1/8	3 1/8	3 5/8	3 5/8
480,000	2 1/8	2 5/8	2 5/8	3 1/8	3 1/8	3 5/8	2 5/8	2 5/8	2 5/8	2 5/8	3 5/8	3 5/8	2 5/8	3 1/8	3 1/8	3 5/8	3 5/8	4 1/8
600,000	2 5/8	2 5/8	3 1/8	3 1/8	3 5/8	3 5/8	2 5/8	2 5/8	3 1/8	3 1/8	3 5/8	3 5/8	3 1/8	3 1/8	3 1/8	3 5/8	4 1/8	4 1/8

*** NOTES:**

1. Sizes that are highlighted indicate maximum suction line sizes that should be used for risers. Riser size should not exceed horizontal size. Properly placed suction traps must also be used for adequate oil return. All sizes shown are for O.D. Type L copper tubing.
2. Suction line sizes selected at pressure drop equivalent to 2°F. Reduce estimate of system capacity accordingly.
3. If system load drops below 40% of design, consideration to installing double suction risers should be made.
4. R407A, R407C, R407F

Line Sizing

Table 2. Recommended Line Sizes for R-448A/R-449A (cont.)*

System Capacity BTU/H	SUCTION LINE SIZE																	
	SUCTION TEMPERATURE																	
	-20 °F Equivalent Lengths						-30 °F Equivalent Lengths						-40 °F Equivalent Lengths					
	25'	50'	75'	100'	150'	200'	25'	50'	75'	100'	150'	200'	25'	50'	75'	100'	150'	200'
1,000	3/8	3/8	1/2	1/2	1/2	1/2	3/8	3/8	1/2	1/2	1/2	5/8	3/8	1/2	1/2	1/2	5/8	5/8
3,000	1/2	1/2	5/8	5/8	7/8	7/8	1/2	1/2	5/8	5/8	7/8	7/8	1/2	1/2	5/8	5/8	7/8	7/8
4,000	1/2	5/8	5/8	7/8	7/8	7/8	5/8	5/8	5/8	7/8	7/8	7/8	1/2	5/8	5/8	7/8	7/8	7/8
6,000	5/8	5/8	7/8	7/8	7/8	7/8	5/8	5/8	7/8	7/8	7/8	7/8	5/8	5/8	7/8	7/8	7/8	1 1/8
9,000	5/8	7/8	7/8	7/8	1 1/8	1 1/8	5/8	7/8	7/8	7/8	1 1/8	1 1/8	5/8	7/8	7/8	7/8	1 1/8	1 1/8
12,000	7/8	7/8	7/8	1 1/8	1 1/8	1 1/8	7/8	7/8	7/8	1 1/8	1 1/8	1 1/8	7/8	7/8	7/8	1 1/8	1 1/8	1 1/8
15,000	7/8	7/8	1 1/8	1 1/8	1 1/8	1 3/8	7/8	7/8	1 1/8	1 1/8	1 1/8	1 3/8	7/8	7/8	1 1/8	1 1/8	1 1/8	1 3/8
18,000	7/8	1 1/8	1 1/8	1 1/8	1 3/8	1 3/8	7/8	1 1/8	1 1/8	1 1/8	1 3/8	1 3/8	7/8	1 1/8	1 1/8	1 1/8	1 3/8	1 3/8
24,000	1 1/8	1 1/8	1 1/8	1 3/8	1 3/8	1 3/8	1 1/8	1 1/8	1 1/8	1 3/8	1 3/8	1 3/8	1 1/8	1 1/8	1 1/8	1 3/8	1 3/8	1 3/8
30,000	1 1/8	1 1/8	1 1/8	1 3/8	1 3/8	1 5/8	1 1/8	1 1/8	1 3/8	1 3/8	1 3/8	1 5/8	1 1/8	1 1/8	1 3/8	1 3/8	1 3/8	1 5/8
36,000	1 1/8	1 1/8	1 3/8	1 3/8	1 3/8	1 5/8	1 1/8	1 3/8	1 3/8	1 3/8	1 3/8	1 5/8	1 1/8	1 3/8	1 3/8	1 3/8	1 5/8	1 5/8
42,000	1 1/8	1 3/8	1 3/8	1 5/8	1 5/8	1 5/8	1 1/8	1 3/8	1 3/8	1 3/8	1 5/8	1 5/8	1 1/8	1 3/8	1 3/8	1 3/8	1 5/8	1 5/8
48,000	1 1/8	1 3/8	1 3/8	1 5/8	1 5/8	1 5/8	1 1/8	1 3/8	1 3/8	1 3/8	1 5/8	1 5/8	1 1/8	1 3/8	1 3/8	1 3/8	1 5/8	1 5/8
54,000	1 3/8	1 3/8	1 5/8	1 5/8	1 5/8	1 5/8	1 3/8	1 3/8	1 3/8	1 5/8	1 5/8	2 1/8	1 3/8	1 3/8	1 3/8	1 5/8	1 5/8	2 1/8
60,000	1 3/8	1 3/8	1 5/8	1 5/8	1 5/8	2 1/8	1 3/8	1 3/8	1 5/8	1 5/8	1 5/8	2 1/8	1 3/8	1 3/8	1 5/8	1 5/8	1 5/8	2 1/8
66,000	1 3/8	1 5/8	1 5/8	1 5/8	1 5/8	2 1/8	1 3/8	1 5/8	1 5/8	1 5/8	1 5/8	2 1/8	1 3/8	1 5/8	1 5/8	1 5/8	1 5/8	2 1/8
72,000	1 3/8	1 5/8	1 5/8	1 5/8	1 5/8	2 1/8	1 3/8	1 5/8	1 5/8	1 5/8	1 5/8	2 1/8	1 3/8	1 5/8	1 5/8	1 5/8	1 5/8	2 1/8
78,000	1 5/8	1 5/8	1 5/8	1 5/8	2 1/8	2 1/8	1 5/8	1 5/8	1 5/8	1 5/8	2 1/8	2 1/8	1 5/8	1 5/8	1 5/8	1 5/8	2 1/8	2 1/8
84,000	1 5/8	1 5/8	1 5/8	2 1/8	2 1/8	2 1/8	1 5/8	1 5/8	1 5/8	2 1/8	2 1/8	2 1/8	1 5/8	1 5/8	1 5/8	2 1/8	2 1/8	2 1/8
90,000	1 5/8	1 5/8	2 1/8	2 1/8	2 1/8	2 5/8	1 5/8	2 1/8	2 1/8	2 1/8	2 1/8	2 5/8	1 5/8	1 5/8	2 1/8	2 1/8	2 1/8	2 5/8
120,000	1 5/8	2 1/8	2 1/8	2 1/8	2 5/8	2 5/8	1 5/8	2 1/8	2 1/8	2 1/8	2 5/8	2 5/8	1 5/8	2 1/8	2 1/8	2 1/8	2 5/8	2 5/8
150,000	2 1/8	2 1/8	2 1/8	2 5/8	2 5/8	2 5/8	2 1/8	2 1/8	2 1/8	2 5/8	2 5/8	2 5/8	2 1/8	2 1/8	2 5/8	2 5/8	2 5/8	2 5/8
180,000	2 1/8	2 1/8	2 5/8	2 5/8	2 5/8	3 1/8	2 1/8	2 1/8	2 5/8	2 5/8	2 5/8	3 1/8	2 1/8	2 1/8	2 5/8	2 5/8	2 5/8	3 1/8
210,000	2 1/8	2 5/8	2 5/8	2 5/8	3 1/8	3 1/8	2 1/8	2 5/8	2 5/8	2 5/8	3 1/8	3 1/8	2 1/8	2 5/8	2 5/8	2 5/8	3 1/8	3 1/8
240,000	2 1/8	2 5/8	2 5/8	2 5/8	3 1/8	3 1/8	2 5/8	2 5/8	2 5/8	3 1/8	3 1/8	3 5/8	2 5/8	2 5/8	2 5/8	3 1/8	3 1/8	3 5/8
300,000	2 5/8	2 5/8	2 5/8	3 1/8	3 5/8	3 5/8	2 5/8	2 5/8	3 1/8	3 1/8	3 5/8	4 1/8	2 5/8	2 5/8	3 1/8	3 5/8	3 5/8	4 1/8
360,000	2 5/8	2 5/8	3 1/8	3 5/8	3 5/8	4 1/8	2 5/8	3 1/8	3 5/8	3 5/8	3 5/8	4 1/8	2 5/8	3 1/8	3 5/8	3 5/8	4 1/8	4 1/8
480,000	2 5/8	3 1/8	3 1/8	3 5/8	3 5/8	4 1/8	3 1/8	3 5/8	3 5/8	4 1/8	4 1/8	4 1/8	3 1/8	3 5/8	3 5/8	4 1/8	4 1/8	4 1/8
600,000	3 1/8	3 1/8	3 1/8	3 5/8	3 5/8	4 1/8	3 1/8	3 5/8	3 5/8	4 1/8	4 1/8	5 1/8	3 1/8	3 5/8	3 5/8	4 1/8	4 1/8	5 1/8

Line Sizing

Table 2A. Recommended Line Sizes for R-448A/R-449A

LIQUID LINE SIZE						System Capacity BTU/H
Receiver to Expansion Valve						
25'	50'	75'	100'	150'	200'	
3/8	3/8	3/8	3/8	3/8	3/8	1,000
3/8	3/8	3/8	3/8	3/8	3/8	3,000
3/8	3/8	3/8	3/8	3/8	3/8	4,000
3/8	3/8	3/8	3/8	3/8	3/8	6,000
3/8	3/8	3/8	3/8	3/8	3/8	9,000
3/8	3/8	3/8	3/8	3/8	3/8	12,000
3/8	3/8	3/8	3/8	3/8	1/2	15,000
3/8	3/8	3/8	3/8	1/2	1/2	18,000
3/8	3/8	1/2	1/2	1/2	1/2	24,000
3/8	3/8	1/2	1/2	1/2	1/2	30,000
3/8	1/2	1/2	1/2	1/2	1/2	36,000
3/8	1/2	1/2	1/2	1/2	5/8	42,000
1/2	1/2	1/2	1/2	1/2	5/8	48,000
1/2	1/2	1/2	1/2	5/8	5/8	54,000
1/2	1/2	1/2	5/8	5/8	5/8	60,000
1/2	1/2	5/8	5/8	5/8	5/8	66,000
1/2	1/2	5/8	5/8	5/8	5/8	72,000
1/2	1/2	5/8	5/8	5/8	7/8	78,000
1/2	5/8	5/8	5/8	5/8	7/8	84,000
1/2	5/8	5/8	5/8	7/8	7/8	90,000
5/8	5/8	5/8	7/8	7/8	7/8	120,000
5/8	7/8	7/8	7/8	7/8	7/8	150,000
5/8	7/8	7/8	7/8	7/8	1 1/8	180,000
7/8	7/8	7/8	7/8	7/8	1 1/8	210,000
7/8	7/8	7/8	7/8	1 1/8	1 1/8	240,000
7/8	7/8	1 1/8	1 1/8	1 1/8	1 1/8	300,000
7/8	7/8	1 1/8	1 1/8	1 1/8	1 1/8	360,000
1 1/8	1 1/8	1 1/8	1 1/8	1 3/8	1 3/8	480,000
1 1/8	1 1/8	1 1/8	1 3/8	1 3/8	1 3/8	600,000

Line Sizing

Table 3. Recommended Line Sizes for R-404A and R-507 *

System Capacity BTU/H	SUCTION LINE SIZE																				
	SUCTION TEMPERATURE																				
	+40°F						+20°F						+10°F						0°F		
	Equivalent Lengths						Equivalent Lengths						Equivalent Lengths						Equivalent		
	25'	50'	75'	100'	150'	200'	25'	50'	75'	100'	150'	200'	25'	50'	75'	100'	150'	200'	25'	50'	75'
1,000	3/8	3/8	3/8	3/8	3/8	3/8	3/8	3/8	3/8	3/8	3/8	1/2	3/8	3/8	3/8	1/2	1/2	1/2	3/8	3/8	1/2
3,000	3/8	3/8	1/2	1/2	1/2	5/8	3/8	1/2	1/2	1/2	5/8	5/8	1/2	1/2	5/8	5/8	5/8	7/8	1/2	1/2	5/8
4,000	3/8	1/2	1/2	1/2	5/8	5/8	1/2	1/2	1/2	5/8	5/8	7/8	1/2	5/8	5/8	5/8	7/8	7/8	1/2	5/8	5/8
6,000	1/2	1/2	5/8	5/8	7/8	7/8	1/2	1/2	5/8	5/8	7/8	7/8	1/2	5/8	5/8	7/8	7/8	7/8	5/8	5/8	7/8
9,000	5/8	5/8	7/8	7/8	7/8	7/8	5/8	5/8	7/8	7/8	7/8	7/8	5/8	7/8	7/8	7/8	7/8	11/8	5/8	7/8	7/8
12,000	5/8	7/8	7/8	7/8	7/8	7/8	5/8	7/8	7/8	7/8	7/8	1 1/8	7/8	7/8	7/8	7/8	1 1/8	1 1/8	7/8	7/8	7/8
15,000	5/8	7/8	7/8	7/8	7/8	1 1/8	7/8	7/8	7/8	7/8	1 1/8	1 1/8	7/8	7/8	7/8	1 1/8	1 1/8	1 1/8	7/8	7/8	1 1/8
18,000	7/8	7/8	7/8	7/8	1 1/8	1 1/8	7/8	7/8	7/8	1 1/8	1 1/8	1 1/8	7/8	7/8	1 1/8	1 1/8	1 1/8	1 3/8	7/8	1 1/8	1 1/8
24,000	7/8	7/8	7/8	1 1/8	1 1/8	1 1/8	7/8	1 1/8	1 1/8	1 1/8	1 1/8	1 3/8	7/8	1 1/8	1 1/8	1 1/8	1 3/8	1 3/8	1 1/8	1 1/8	1 1/8
30,000	7/8	7/8	1 1/8	1 1/8	1 1/8	1 3/8	7/8	1 1/8	1 1/8	1 1/8	1 3/8	1 3/8	1 1/8	1 1/8	1 1/8	1 3/8	1 3/8	1 3/8	1 1/8	1 1/8	1 1/8
36,000	7/8	1 1/8	1 1/8	1 1/8	1 3/8	1 3/8	1 1/8	1 1/8	1 1/8	1 3/8	1 3/8	1 3/8	1 1/8	1 1/8	1 3/8	1 3/8	1 3/8	1 5/8	1 1/8	1 1/8	1 3/8
42,000	1 1/8	1 1/8	1 1/8	1 3/8	1 3/8	1 3/8	1 1/8	1 1/8	1 3/8	1 3/8	1 3/8	1 5/8	1 1/8	1 3/8	1 3/8	1 3/8	1 5/8	1 5/8	1 1/8	1 3/8	1 3/8
48,000	1 1/8	1 1/8	1 3/8	1 3/8	1 3/8	1 3/8	1 1/8	1 1/8	1 3/8	1 3/8	1 5/8	1 5/8	1 1/8	1 3/8	1 3/8	1 3/8	1 5/8	1 5/8	1 1/8	1 3/8	1 3/8
54,000	1 1/8	1 1/8	1 3/8	1 3/8	1 3/8	1 5/8	1 1/8	1 3/8	1 3/8	1 3/8	1 5/8	1 5/8	1 3/8	1 3/8	1 3/8	1 5/8	1 5/8	1 5/8	1 3/8	1 3/8	1 5/8
60,000	1 1/8	1 1/8	1 3/8	1 3/8	1 5/8	1 5/8	1 1/8	1 3/8	1 3/8	1 5/8	1 5/8	1 5/8	1 3/8	1 3/8	1 5/8	1 5/8	1 5/8	2 1/8	1 3/8	1 3/8	1 5/8
66,000	1 1/8	1 3/8	1 3/8	1 3/8	1 5/8	1 5/8	1 1/8	1 3/8	1 3/8	1 5/8	1 5/8	1 5/8	1 3/8	1 5/8	1 5/8	1 5/8	1 5/8	1 5/8	1 3/8	1 5/8	1 5/8
72,000	1 1/8	1 3/8	1 3/8	1 5/8	1 5/8	1 5/8	1 1/8	1 3/8	1 5/8	1 5/8	1 5/8	1 5/8	1 3/8	1 5/8	1 5/8	1 5/8	1 5/8	1 5/8	1 3/8	1 5/8	1 5/8
78,000	1 1/8	1 3/8	1 3/8	1 5/8	1 5/8	2 1/8	1 3/8	1 3/8	1 5/8	1 5/8	1 5/8	2 1/8	1 3/8	1 5/8	1 5/8	1 5/8	1 5/8	2 1/8	1 5/8	1 5/8	1 5/8
84,000	1 1/8	1 3/8	1 5/8	1 5/8	1 5/8	2 1/8	1 3/8	1 3/8	1 5/8	1 5/8	2 1/8	2 1/8	1 3/8	1 5/8	1 5/8	1 5/8	2 1/8	2 1/8	1 5/8	1 5/8	1 5/8
90,000	1 3/8	1 3/8	1 5/8	1 5/8	2 1/8	2 1/8	1 3/8	1 5/8	1 5/8	1 5/8	2 1/8	2 1/8	1 5/8	1 5/8	1 5/8	2 1/8	2 1/8	2 5/8	1 5/8	1 5/8	2 1/8
120,000	1 3/8	1 5/8	1 5/8	2 1/8	2 1/8	2 1/8	1 3/8	1 5/8	2 1/8	2 1/8	2 1/8	2 1/8	1 5/8	2 1/8	2 1/8	2 1/8	2 5/8	2 5/8	1 5/8	2 1/8	2 1/8
150,000	1 5/8	1 5/8	2 1/8	2 1/8	2 1/8	2 1/8	1 5/8	2 1/8	2 1/8	2 1/8	2 1/8	2 5/8	2 1/8	2 1/8	2 1/8	2 5/8	2 5/8	2 5/8	2 1/8	2 1/8	2 1/8
180,000	1 5/8	2 1/8	2 1/8	2 1/8	2 1/8	2 5/8	1 5/8	2 1/8	2 1/8	2 1/8	2 5/8	2 5/8	2 1/8	2 1/8	2 5/8	2 5/8	2 5/8	3 1/8	2 1/8	2 1/8	2 5/8
210,000	1 5/8	2 1/8	2 1/8	2 1/8	2 5/8	2 5/8	2 1/8	2 1/8	2 1/8	2 5/8	2 5/8	2 5/8	2 1/8	2 1/8	2 5/8	2 5/8	3 1/8	3 1/8	2 1/8	2 5/8	2 5/8
240,000	1 5/8	2 1/8	2 1/8	2 1/8	2 5/8	2 5/8	2 1/8	2 1/8	2 5/8	2 5/8	2 5/8	2 5/8	2 1/8	2 5/8	2 5/8	2 5/8	3 1/8	3 1/8	2 1/8	2 5/8	2 5/8
300,000	2 1/8	2 1/8	2 5/8	2 5/8	2 5/8	3 1/8	2 1/8	2 5/8	2 5/8	2 5/8	3 1/8	3 1/8	2 5/8	2 5/8	2 5/8	3 1/8	3 1/8	3 5/8	2 5/8	2 5/8	2 5/8
360,000	2 1/8	2 1/8	2 5/8	2 5/8	3 1/8	3 1/8	2 1/8	2 5/8	2 5/8	2 5/8	3 1/8	3 1/8	2 5/8	2 5/8	3 1/8	3 1/8	3 5/8	3 5/8	2 5/8	2 5/8	3 1/8
480,000	2 1/8	2 5/8	2 5/8	3 1/8	3 1/8	3 5/8	2 5/8	2 5/8	2 5/8	2 5/8	3 5/8	3 5/8	2 5/8	3 1/8	3 1/8	3 5/8	3 5/8	4 1/8	2 5/8	3 1/8	3 1/8
600,000	2 5/8	2 5/8	3 1/8	3 1/8	3 5/8	3 5/8	2 5/8	2 5/8	3 1/8	3 1/8	3 5/8	3 5/8	3 1/8	3 1/8	3 1/8	3 5/8	4 1/8	4 1/8	3 1/8	3 1/8	3 1/8

*** NOTES:**

- Sizes that are highlighted indicate maximum suction line sizes that should be used for risers. Riser size should not exceed horizontal size. Properly placed suction traps must also be used for adequate oil return.
All sizes shown are for O.D. Type L copper tubing.
- Suction line sizes selected at pressure drop equivalent to 2°F. Reduce estimate of system capacity accordingly.
- If system load drops below 40% of design, consideration to installing double suction risers should be made.

Line Sizing

Table 3A. Recommended Line Sizes for R-404A and R-507 (continued) *

SUCTION LINE SIZE															LIQUID LINE SIZE						System Capacity BTU/H
SUCTION TEMPERATURE															Receiver to Expansion Valve Equivalent Lengths						
-20°F Lengths			-30°F Equivalent Lengths						-40°F Equivalent Lengths												
100'	150'	200'	25'	50'	75'	100'	150'	200'	25'	50'	75'	100'	150'	200'	25'	50'	75'	100'	150'	200'	
1/2	1/2	1/2	3/8	3/8	1/2	1/2	1/2	5/8	3/8	1/2	1/2	1/2	5/8	5/8	3/8	3/8	3/8	3/8	3/8	3/8	1,000
5/8	7/8	7/8	1/2	1/2	5/8	5/8	7/8	7/8	1/2	1/2	5/8	5/8	7/8	7/8	3/8	3/8	3/8	3/8	3/8	3/8	3,000
7/8	7/8	7/8	5/8	5/8	5/8	7/8	7/8	7/8	1/2	5/8	5/8	7/8	7/8	7/8	3/8	3/8	3/8	3/8	3/8	3/8	4,000
7/8	7/8	7/8	5/8	5/8	7/8	7/8	7/8	7/8	5/8	5/8	7/8	7/8	7/8	1 1/8	3/8	3/8	3/8	3/8	3/8	3/8	6,000
7/8	1 1/8	1 1/8	5/8	7/8	7/8	7/8	1 1/8	1 1/8	5/8	7/8	7/8	7/8	1 1/8	1 1/8	3/8	3/8	3/8	3/8	3/8	3/8	9,000
1 1/8	1 1/8	1 1/8	7/8	7/8	7/8	1 1/8	1 1/8	1 1/8	7/8	7/8	7/8	1 1/8	1 1/8	1 1/8	3/8	3/8	3/8	3/8	3/8	1/2	12,000
1 1/8	1 1/8	1 3/8	7/8	7/8	1 1/8	1 1/8	1 1/8	1 3/8	7/8	7/8	1 1/8	1 1/8	1 1/8	1 3/8	3/8	3/8	3/8	3/8	1/2	1/2	15,000
1 1/8	1 3/8	1 3/8	7/8	1 1/8	1 1/8	1 1/8	1 3/8	1 3/8	7/8	1 1/8	1 1/8	1 1/8	1 3/8	1 3/8	3/8	3/8	3/8	1/2	1/2	1/2	18,000
1 3/8	1 3/8	1 3/8	1 1/8	1 1/8	1 1/8	1 3/8	1 3/8	1 3/8	1 1/8	1 1/8	1 1/8	1 3/8	1 3/8	1 3/8	3/8	3/8	1/2	1/2	1/2	1/2	24,000
1 3/8	1 3/8	1 5/8	1 1/8	1 1/8	1 3/8	1 3/8	1 3/8	1 5/8	1 1/8	1 1/8	1 3/8	1 3/8	1 3/8	1 5/8	3/8	1/2	1/2	1/2	1/2	1/2	30,000
1 3/8	1 3/8	1 5/8	1 1/8	1 3/8	1 3/8	1 3/8	1 3/8	1 5/8	1 1/8	1 3/8	1 3/8	1 3/8	1 5/8	1 5/8	1/2	1/2	1/2	1/2	1/2	5/8	36,000
1 5/8	1 5/8	1 5/8	1 1/8	1 3/8	1 3/8	1 3/8	1 5/8	1 5/8	1 1/8	1 3/8	1 3/8	1 3/8	1 5/8	1 5/8	1/2	1/2	1/2	1/2	5/8	5/8	42,000
1 5/8	1 5/8	1 5/8	1 1/8	1 3/8	1 3/8	1 3/8	1 5/8	1 5/8	1 1/8	1 3/8	1 3/8	1 3/8	1 5/8	1 5/8	1/2	1/2	1/2	5/8	5/8	5/8	48,000
1 5/8	1 5/8	1 5/8	1 3/8	1 3/8	1 3/8	1 5/8	1 5/8	2 1/8	1 3/8	1 3/8	1 3/8	1 5/8	1 5/8	2 1/8	1/2	1/2	1/2	5/8	5/8	5/8	54,000
1 5/8	1 5/8	2 1/8	1 3/8	1 3/8	1 5/8	1 5/8	1 5/8	2 1/8	1 3/8	1 3/8	1 5/8	1 5/8	1 5/8	2 1/8	1/2	1/2	5/8	5/8	5/8	5/8	60,000
1 5/8	1 5/8	2 1/8	1 3/8	1 5/8	1 5/8	1 5/8	1 5/8	2 1/8	1 3/8	1 5/8	1 5/8	1 5/8	1 5/8	2 1/8	1/2	1/2	5/8	5/8	5/8	5/8	66,000
1 5/8	1 5/8	2 1/8	1 3/8	1 5/8	1 5/8	1 5/8	1 5/8	2 1/8	1 3/8	1 5/8	1 5/8	1 5/8	1 5/8	2 1/8	1/2	5/8	5/8	5/8	5/8	5/8	72,000
1 5/8	2 1/8	2 1/8	1 5/8	1 5/8	1 5/8	1 5/8	2 1/8	2 1/8	1 5/8	1 5/8	1 5/8	1 5/8	2 1/8	2 1/8	5/8	5/8	5/8	5/8	5/8	7/8	78,000
2 1/8	2 1/8	2 1/8	1 5/8	1 5/8	1 5/8	2 1/8	2 1/8	2 1/8	1 5/8	1 5/8	1 5/8	2 1/8	2 1/8	2 1/8	5/8	5/8	5/8	5/8	7/8	7/8	84,000
2 1/8	2 1/8	2 5/8	1 5/8	2 1/8	2 1/8	2 1/8	2 1/8	2 5/8	1 5/8	1 5/8	2 1/8	2 1/8	2 1/8	2 5/8	5/8	5/8	5/8	7/8	7/8	7/8	90,000
2 1/8	2 5/8	2 5/8	1 5/8	2 1/8	2 1/8	2 1/8	2 5/8	2 5/8	1 5/8	2 1/8	2 1/8	2 1/8	2 5/8	2 5/8	5/8	5/8	7/8	7/8	7/8	7/8	120,000
2 5/8	2 5/8	2 5/8	2 1/8	2 1/8	2 1/8	2 5/8	2 5/8	2 5/8	2 1/8	2 1/8	2 5/8	2 5/8	2 5/8	2 5/8	5/8	7/8	7/8	7/8	7/8	1 1/8	150,000
2 5/8	2 5/8	3 1/8	2 1/8	2 1/8	2 5/8	2 5/8	2 5/8	3 1/8	2 1/8	2 1/8	2 5/8	2 5/8	2 5/8	3 1/8	7/8	7/8	7/8	7/8	1 1/8	1 1/8	180,000
2 5/8	3 1/8	3 1/8	2 1/8	2 5/8	2 5/8	2 5/8	3 1/8	3 1/8	2 1/8	2 5/8	2 5/8	2 5/8	3 1/8	3 1/8	7/8	7/8	7/8	1 1/8	1 1/8	1 1/8	210,000
2 5/8	3 1/8	3 1/8	2 5/8	2 5/8	2 5/8	3 1/8	3 1/8	3 5/8	2 5/8	2 5/8	2 5/8	3 1/8	3 1/8	3 5/8	7/8	7/8	1 1/8	1 1/8	1 1/8	1 3/8	240,000
3 1/8	3 5/8	3 5/8	2 5/8	2 5/8	3 1/8	3 1/8	3 5/8	4 1/8	2 5/8	2 5/8	3 1/8	3 5/8	3 5/8	4 1/8	7/8	1 1/8	1 1/8	1 1/8	1 3/8	1 3/8	300,000
3 5/8	3 5/8	4 1/8	2 5/8	3 1/8	3 1/8	3 5/8	3 5/8	4 1/8	2 5/8	3 1/8	3 5/8	3 5/8	4 1/8	4 1/8	1 1/8	1 1/8	1 1/8	1 3/8	1 3/8	1 5/8	360,000
3 5/8	3 5/8	4 1/8	3 1/8	3 5/8	3 5/8	4 1/8	4 1/8	4 1/8	3 1/8	3 5/8	3 5/8	4 1/8	4 1/8	4 1/8	1 1/8	1 1/8	1 3/8	1 3/8	1 5/8	1 5/8	480,000
3 5/8	3 5/8	4 1/8	3 1/8	3 5/8	3 5/8	4 1/8	4 1/8	5 1/8	3 1/8	3 5/8	3 5/8	4 1/8	4 1/8	5 1/8	1 1/8	1 3/8	1 3/8	1 5/8	1 5/8	1 5/8	600,000

*** NOTES:**

- Sizes that are highlighted indicate maximum suction line sizes that should be used for risers. Riser size should not exceed horizontal size. Properly placed suction traps must also be used for adequate oil return.
All sizes shown are for O.D. Type L copper tubing.
- Suction line sizes selected at pressure drop equivalent to 2°F. Reduce estimate of system capacity accordingly.
- If system load drops below 40% of design, consideration to installing double suction risers should be made.

Line Sizing

Table 4. Weight of Refrigerants in Copper Lines During Operation (Pounds per 100 Lineal feet of type "L" tubing)

Line Size O.D. in Inches	Refrigerant	Liquid Line	Suction Line at Suction Temperature				
			-40°F	-20°F	0°F	+20°F	+40°F
3/8	R-507/R-404A	3.4	.03	.04	.06	.09	.13
	R-407	3.8	.02	.03	.04	.06	.09
	R-448A/R-449A	3.6	.02	.03	.04	.06	.09
1/2	R-507/R-404A	6.3	.04	.07	.13	.16	.24
	R-407	7.0	.03	.05	.08	.11	.17
	R-448A/R-449A	6.7	.03	.05	.07	.11	.16
5/8	R-507/R-404A	10.2	.07	.11	.17	.25	.35
	R-407	11.2	.05	.08	.12	.18	.26
	R-448A/R-449A	10.8	.05	.08	.12	.18	.26
7/8	R-507/R-404A	21.1	.07	.11	.17	.15	.35
	R-407	23.3	.05	.08	.12	.18	.26
	R-448A/R-449A	22.3	.10	.16	.25	.37	.54
1 1/8	R-507/R-404A	36.1	.15	.23	.37	.51	.72
	R-407	39.7	.10	.16	.25	.37	.54
	R-448A/R-449A	38.1	.17	.27	.42	.63	.92
1 3/8	R-507/R-404A	54.9	.26	.39	.63	.86	1.24
	R-407	60.5	.17	.27	.43	.63	.93
	R-448A/R-449A	58.0	.25	.41	.64	.96	1.40
1 5/8	R-507/R-404A	77.7	.40	.58	.95	1.32	1.87
	R-407	85.7	.26	.41	.65	.96	1.43
	R-448A/R-449A	82.1	.36	.58	.90	1.36	1.98
2 1/8	R-507/R-404A	135	.56	.82	1.35	1.86	2.64
	R-407	149	.36	.57	.91	1.38	2.01
	R-448A/R-449A	143	.62	1.01	1.57	2.36	3.44
2 5/8	R-507/R-404A	209	.98	1.43	2.35	3.23	4.58
	R-407	230	.63	1.00	1.60	2.38	3.49
	R-448A/R-449A	220	.96	1.56	2.42	3.65	5.30
3 1/8	R-507/R-404A	298	1.51	2.21	3.62	5.00	7.07
	R-407	328	.98	1.55	2.46	3.67	5.39
	R-448A/R-449A	314	1.37	2.22	3.45	5.20	7.57
3 5/8	R-507/R-404A	403	2.16	3.15	5.17	7.14	9.95
	R-407	444	1.40	2.23	3.50	5.23	8.27
	R-448A/R-449A	425	1.86	3.01	4.67	7.04	10.24
4 1/8	R-507/R-404A	523	3.80	5.55	9.09	12.58	13.61
	R-407	577	2.45	3.92	6.17	17.80	9.23
	R-448A/R-449A	552	2.40	3.89	6.05	9.11	13.25

Line Sizing

Table 5. Pressure Loss of Liquid Refrigerants in Liquid Line Risers (Expressed in Pressure Drop, PSIG, and Subcooling Loss, °F).

Refrigerant	Liquid Line Rise in Feet																	
	10'		15'		20'		25'		30'		40'		50'		75'		100'	
	PSIG	°F	PSIG	°F	PSIG	°F	PSIG	°F	PSIG	°F	PSIG	°F	PSIG	°F	PSIG	°F	PSIG	°F
R-134A	4.9	2.0	7.4	2.9	9.8	4.1	12.3	5.2	14.7	6.3	19.7	8.8	24.6	11.0	36.8	17.0	49.1	23.7
R-507/R-404A	4.1	1.1	6.1	1.6	8.2	2.1	10.2	2.7	12.2	3.3	16.3	4.1	20.4	5.6	30.6	8.3	40.8	11.8
R-407	4.3	1.4	6.4	2.0	8.5	2.7	10.6	3.4	12.8	4.1	17.0	5.4	21.3	6.8	39.1	10.1	42.5	13.5
R-448A/R-449A	4.3	1.1	6.5	1.7	8.7	2.3	10.9	2.8	13.0	3.4	17.4	4.5	21.7	5.6	32.6	8.3	43.5	10.9

Note: Based on 110°F liquid temperature at bottom of riser.

Table 6. Equivalent Feet of Pipe Due to Valve and Fitting Friction

Copper Tube, O.D., Type "L"	1/2	5/8	7/8	1 1/8	1 3/8	1 5/8	2 1/8	2 5/8	3 1/8	3 5/8	4 1/8	5 1/8	6 1/8
Globe Valve (Open)	14	16	22	28	36	42	57	69	83	99	118	138	168
Angle Valve (Open)	7	9	12	15	18	21	28	34	42	49	57	70	83
90° Turn Through Tee	3	4	5	6	8	9	12	14	17	20	22	28	34
Tee (Straight Through) or Sweep Below	.75	1	1.5	2	2.5	3	3.5	4	5	6	7	9	11
90° Elbow or Reducing Tee (Straight Through)	1	2	2	3	4	4	5	7	8	10	12	14	16

Optional Controls

Head Pressure Control

A. Dual Valve System

The system employs an ORI (open on rise of inlet pressure) valve and an ORD (open on rise of differential pressure) valve.

When operating below the head pressure set point, the ORI valve restricts refrigerant flow. As refrigerant backs up and floods the condenser, the discharge pressure increases. If the refrigerant flow is sufficiently restricted, the ORD valve bypasses refrigerant discharge gas downstream of the ORI. Both valves will modulate to maintain the discharge pressure setting.

This system requires additional refrigerant to flood the condenser during low ambient operation. See the Refrigerant Charging Section for more information.

ORI valve adjustment should be made with a gauge connected to the discharge port of the compressor. Adjustments should be made during mild or low ambient conditions. It may be beneficial to temporarily turn on additional condenser fan(s) to lower the discharge pressure below the desired set point.

Turn the adjustment stem on the ORI with a hex wrench. Clockwise rotation will increase and counterclockwise will decrease the discharge pressure setting.

If adjustments are made during warm ambient conditions, it may not be possible to adjust the ORI valve as low as desired. Readjustment may be necessary once cooler conditions prevail.

Typical ORI discharge pressure settings are 150 to 180 psi. The factory default pressure fan cycle settings (controlled by liquid refrigerant pressure) are appropriate for this range.

If outside of this adjustment range, the condenser fan settings may need to be changed. Note that the liquid pressure will be approximately 20 psi lower than the discharge pressure during low ambient conditions.

If desired, the first fan may be re-programmed to operate with the compressor.

Figure 6. Dual Valve Piping Arrangement

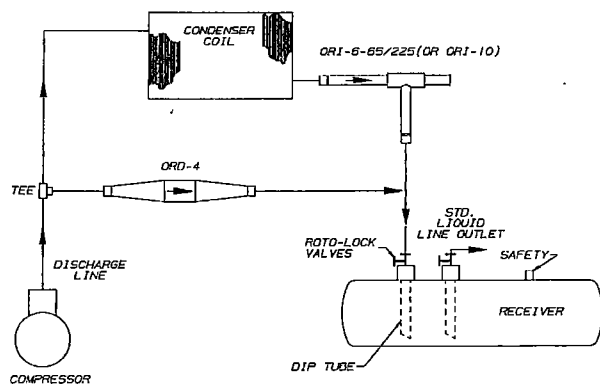

B. Ambient Fan Cycle Control

This is an automatic winter control method which will maintain a condensing pressure within reasonable limits by cycling fan motors in response to outside air temperature. The thermostat(s) should be field adjusted to shut off the fan when the condensing temperature is reduced to approximately 90F. Table 6 lists default settings. These settings are approximate as they do not take into account variations in load.

CAUTION: For Ambient Fan Cycling; Under no circumstance should all condenser motors be allowed to cycle off on one control. At least one motor shall be wired to operate at all times. Under most circumstances, the condenser motor nearest the inlet header should remain on whenever the compressor is operating.

Table 7. Ambient Fan Cycle Default Thermostat Settings

Models	Fan #1	Thermostat Settings °F Cut-In		
		Fan #2	Fan #3	Fan #4
2 Fan Units	ON	50	—	—
3 Fan Units	ON	50	60	—
4 Fan Units	ON	50	60	70

Note: Cut-out temperature is °F below cut-in temperature

C. Phase Loss Monitor

The combination phase sequence and loss monitor relay protects the system against phase loss (single phasing), phase reversal (improper sequence) and low voltage (brownout). When phase sequence is correct and full line voltage is present on all three phases, the relay is energized as the normal condition indicator light glows.

Note: If compressor fails to operate and the normal condition indicator light on the phase monitor does not glow, then the supplied electrical current is not in phase with the monitor. This problem is easily corrected by the following steps:

1. Turn power off at disconnect switch
2. Swap any two of the three power input wires
3. Turn power on. Indicator light should glow and compressor should start
4. Observe motors for correct rotation

D. Evaporator Powered From Condensing Unit

The system may be optionally ordered with the evaporator control contactors mounted in the condensing unit electrical box instead of the evaporator. This arrangement may be desirable for retrofit installations or applications where evaporator access is limited.

Optional Controls

E. Copeland Demand Cooling for Discus L6 Models

Energy efficiency regulations drive continuous change in the availability of refrigerants to the marketplace. With the introduction of R-22 as a replacement for R-502 compressors began to experience internal discharge temperatures that exceed the safe operational limits for long term stability of refrigerant oil. In response to this Demand Cooling was developed as a reliable method to keep discharge temperatures reduced to a safe level without inhibiting the operating limits of the compressor. With the phase out of R-22, the following refrigerants have become viable alternatives: R-407A/C/F and R-448A/449-A. All of these refrigerants require special attention to discharge temperature control. Also for this reason suction to liquid heat exchangers are not recommended unless they are necessary to prevent another potential problem.

The Copeland Demand Cooling System

Copeland's demand cooling system uses modern electronics to provide a reliable, cost-effective solution to this problem. It is required for all single stage required for all single stage R-22, R-407A/C/For R-448A/449-A applications with saturated suction temperatures below 0°F.

The Demand Cooling module uses the signal of a discharge head temperature sensor to monitor discharge gas temperature. If a critical temperature is reached, the module energizes along life injection valve which meters a controlled amount of saturated refrigerant into the compressor suction cavity to cool the suction gas. Refer to Figure 13.

This process controls the discharge temperature to a safe level. If, for some reason, the discharge temperature rises above a preset maximum level, the Demand Cooling module will turn the compressor off (requiring a manual reset) and actuate its alarm contact. To minimize the amount of refrigerant which must be injected, the suction gas cooling process is performed after the gas has passed around and through the motor.

Operating Range

Demand Cooling is designed to protect the compressor from high discharge temperatures over the evaporating and condensing temperature ranges shown in Figure 12 at a maximum return gas temperature of 65°F.

Figure 12. Demand Cooling Injection

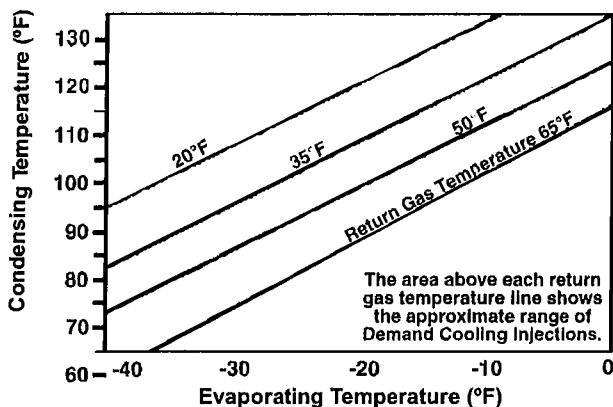

Demand Cooling System Design

When Demand Cooling operates, it "diverts" refrigeration capacity in the form of injected saturated refrigerant from the evaporator to the compressor. The effect of this diversion on evaporator capacity is minimal because the diverted capacity is used to cool the gas entering the compressor. As the gas is cooled, it naturally becomes more dense, increasing the mass flow through the compressor, which partly compensates for the capacity diverted from the evaporator.

1. Compressor Return Gas Temperature: Suction lines should be well insulated to reduce suction line heat gain. Return gas superheat should be as low as possible consistent with safe compressor operation.
2. Condensing Temperatures: It is important when using R-22, R-407 A/C/F or R-448A/449A as a low temperature refrigerant that condensing temperatures be minimized to reduce compression ratios and compressor discharge temperature.
3. Suction Pressure: Evaporator design and system control settings should provide the maximum suction pressure consistent with the application in order to have as low a compression ratio as possible.

In most cases, with floating head systems where condensing temperatures are low during most of the year, Demand Cooling will operate primarily as a compressor protection control much as the oil failure control protects the compressor during periods of low oil pressure. Demand Cooling will be allowed to operate only during those periods when condensing temperatures and return gas temperatures are high or in periods where a system failure (such as an ice evaporator, an expansion valve which does not control superheat, blocked condenser, or a failed condenser fan) raises condensing temperatures or return gas temperatures to abnormally high levels or lowers suction pressure to abnormally low levels.

Figure 13. Single Stage Internal Refrigerant Injection

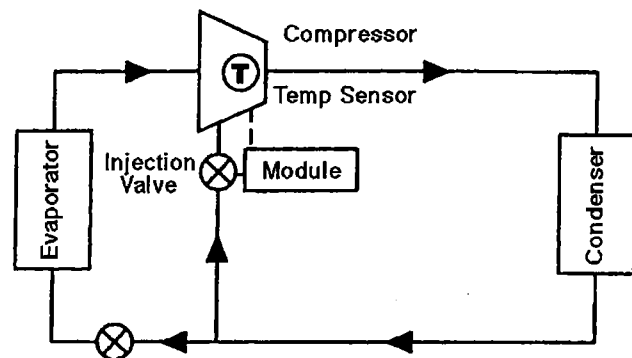

Wiring Installation

Field Wiring

WARNING: All wiring must be done in accordance with applicable codes and local ordinances.

The field wiring should enter the areas as provided on the unit. The wiring diagram for each unit is located on the inside of the electrical panel door. All field wiring should be done in a professional manner and in accordance with all governing codes. Before operating unit, double check all wiring connections, including the factory terminals. Factory connections can vibrate loose during shipment.

1. The serial data tag on the unit is marked with the electrical characteristic for wiring the unit
2. Consult the wiring diagram in the unit cooler and in the condensing unit for proper connections
3. Wire type should be of copper conductor only and of the proper size to handle the connected load
4. The unit must be grounded

General Installation

- Refer to wiring schematic shipped on units for unit wiring.
- The hot gas controller is shipped with preset control settings that are typical for the application. Changes should be made according to directions outlined under Program Settings.
- The condensing unit electrical panel contains the electronic control board. The control board has a terminal block that is labeled to match the low voltage wiring connections going to the evaporator(s). The temperature and pressure sensors located on the condensing unit are pre-connected to the control board at the factory.

Wiring Installation

Wiring between the condensing unit and the unit cooler(s) will be as follows (see wiring diagrams):

High voltage – A separate power supply from the condensing unit may be utilized for the evaporator. All appropriate local codes regarding disconnects and fusing must be followed. See the unit cooler spec. plate for ampacity.

Low voltage – 24 VAC control circuit. Each evaporator connects to the condensing unit with the following connections: defrost termination temperature (2 conductors), liquid line solenoid (2 conductors), evaporator fan contactor control (2 conductors). In addition, some evaporators will require 2 conductors for the pan heater contactor control. Eight-conductor, 18 gauge thermostat wiring is recommended. The thermostat contact connection can be run within this bundle of wires also if there are extra wires available. All 24 volt wiring must be run separate from the line voltage wiring.

Low voltage wiring must be 18 gauge minimum. For low voltage wiring, maximum distance is 500 feet from condensing unit to evaporators.

Alarm circuit – The onboard alarm is a dry set of contacts (Com, NO, NC) which activates to indicate an alarm. The type and wiring for the alarm is customer specified. Note that the alarm circuit does not distinguish or indicate what has caused the alarm. The maximum contact rating is 120V, 0.5A.

Mohave Hot Gas System Controller Battery Back-Up - The control board has a CR2032 (3V) back-up battery with an expected life of 10 years. In the event of battery failure; the system will lose time during power outages but will otherwise operate normally.

Mohave Modbus RS-485

The "A" and "B" terminal signals should be connected to the PC host, and the "COM" terminal should be connected to the PC's digital ground.

If the green LED (BUS indicator) is 'ON' when "A" and "B" are connected to the PC, then these terminals should be swapped so the green LED is 'OFF'.

The green LED should flash when the PC host sends a mod-bus message, and the yellow LED (XMIT indicator) should flash when the Mohave board responds to a query.

Communication Settings:

- Baud Rate: 9600
- Parity: Even
- Data Bits: 8
- Stop Bits: 1

Wiring Diagram

Interconnection Wiring (24V)
 Single Evaporator
 (Standard Independent Evaporator Power Supply)

Control Board-Located at Condensing Unit

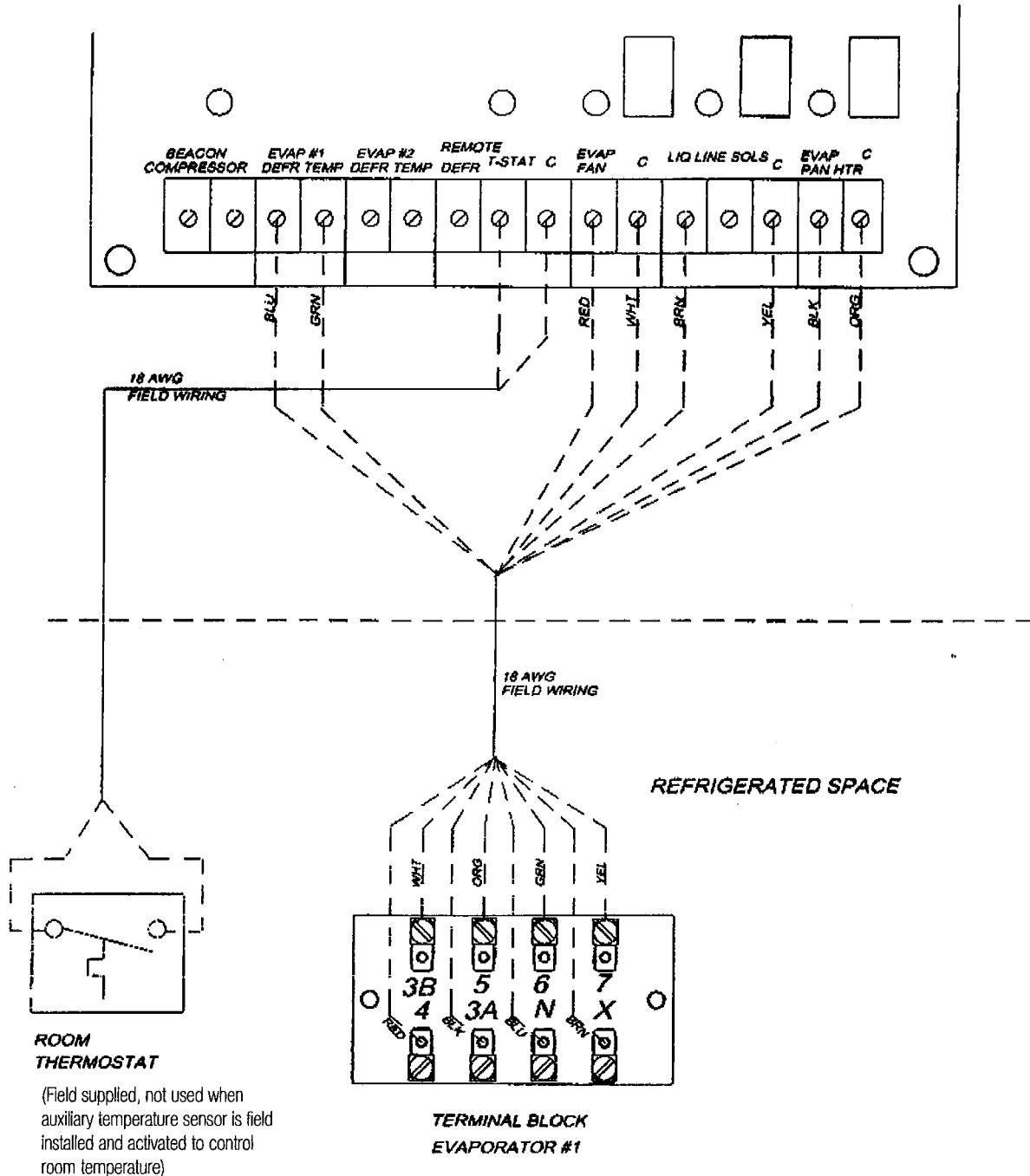

Wiring Diagram

Interconnection Wiring (24V)
Dual Evaporator
(Standard Independent Evaporator Power Supply)

Control Board-Located at Condensing Unit

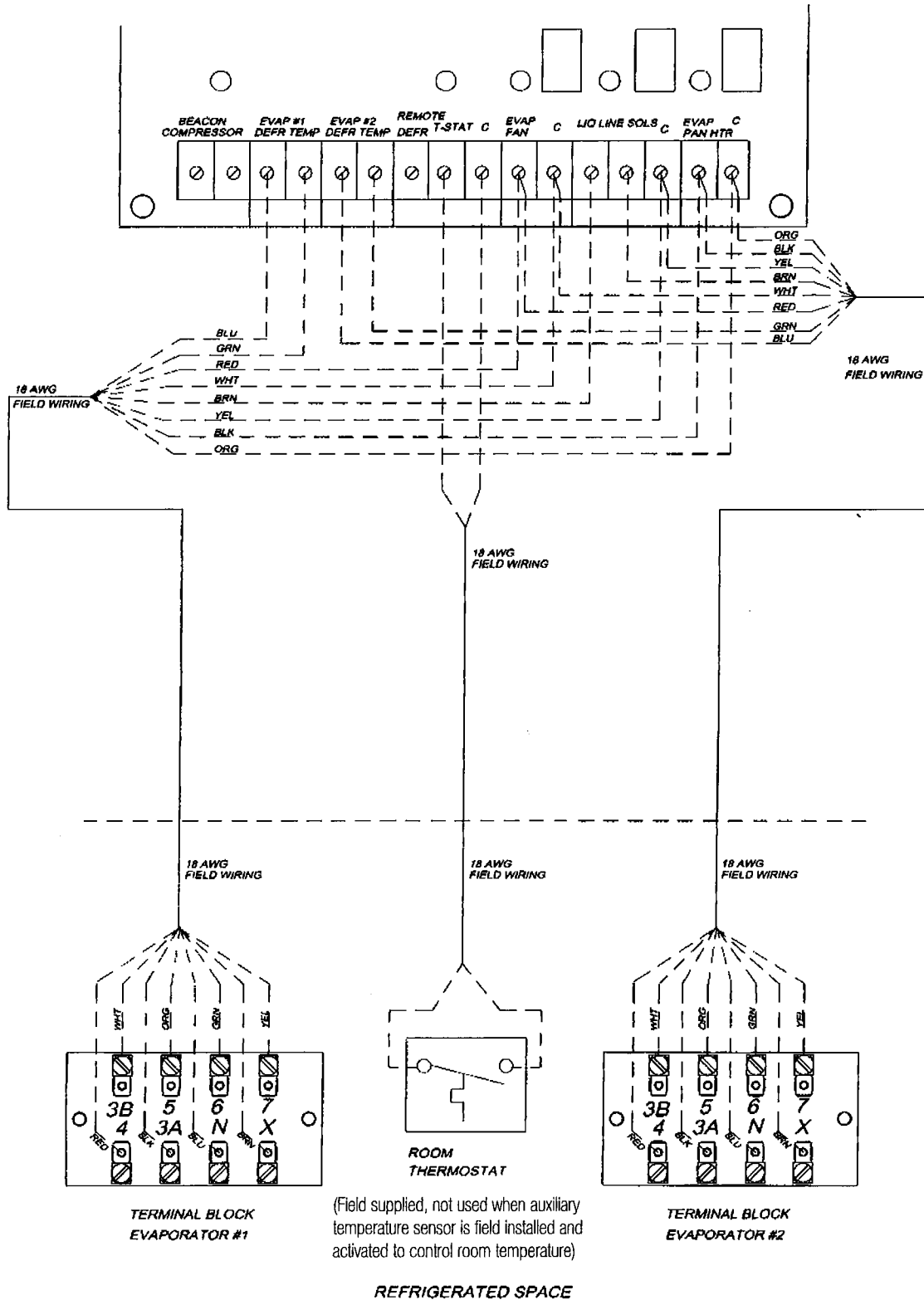

Wiring Diagram

Typical Evaporator Wiring (Electric Drain Pan Heater) (Standard Independent Evaporator Power Supply)

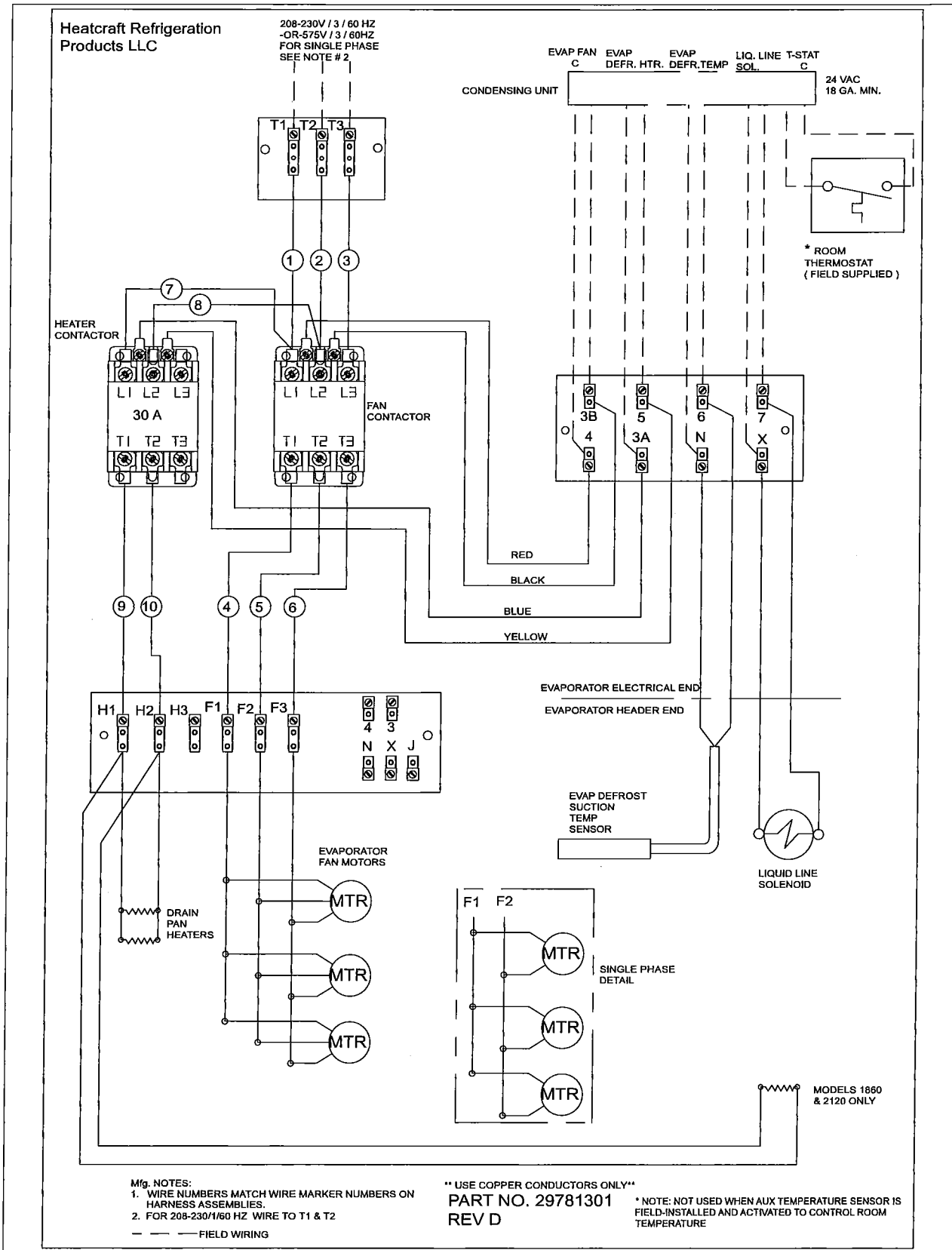

Wiring Diagram

Typical Evaporator Wiring (Hot Gas Drain Pan) (Standard Independent Evaporator Power Supply)

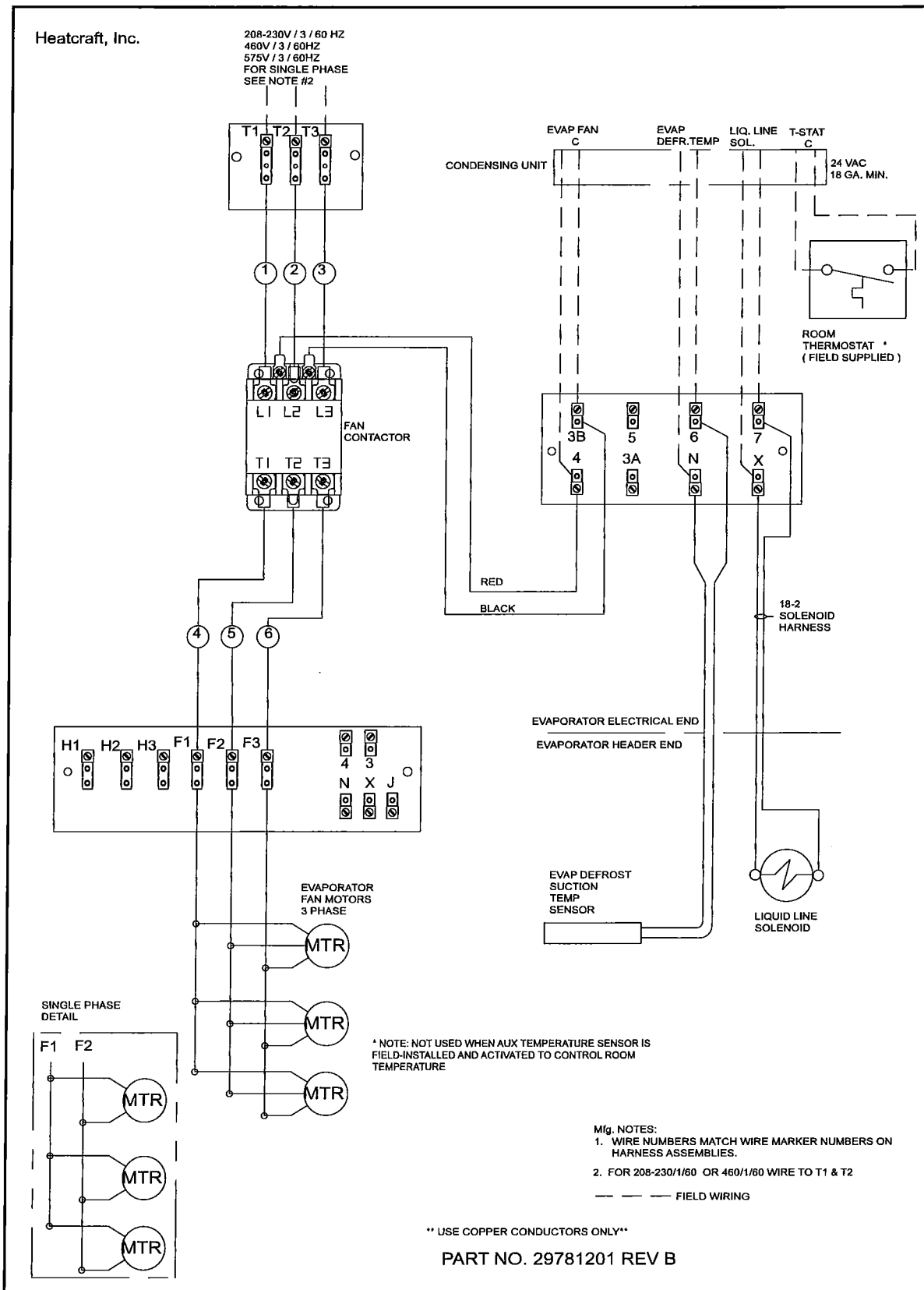

Wiring Diagram

Typical Evaporator Wiring (Hot Gas Drain Pan) (Optional Evaporator Powered Off Condensing Unit)

Heatcraft, Inc.

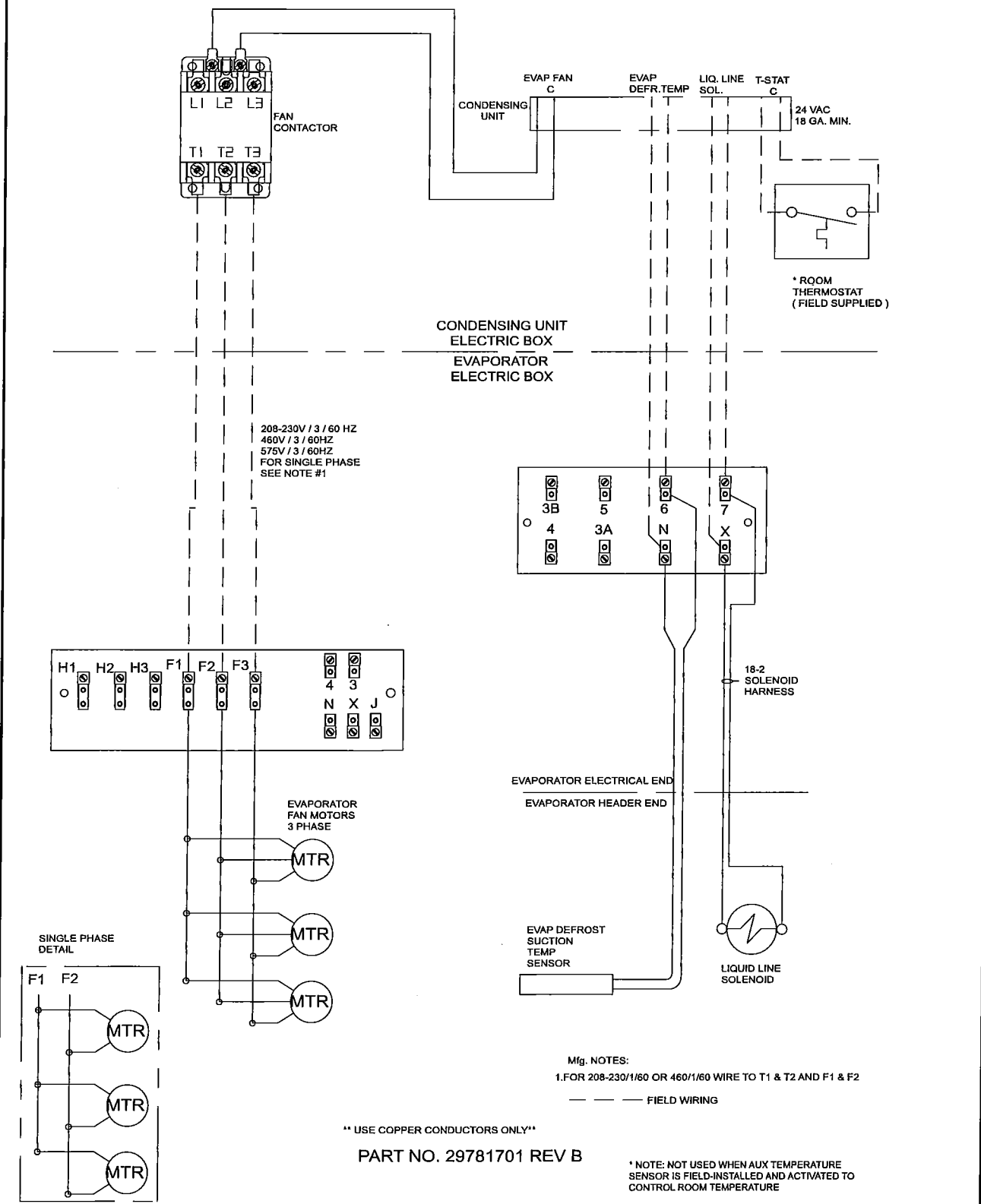

Wiring Diagram

(Standard Independent Evaporator Power Supply)

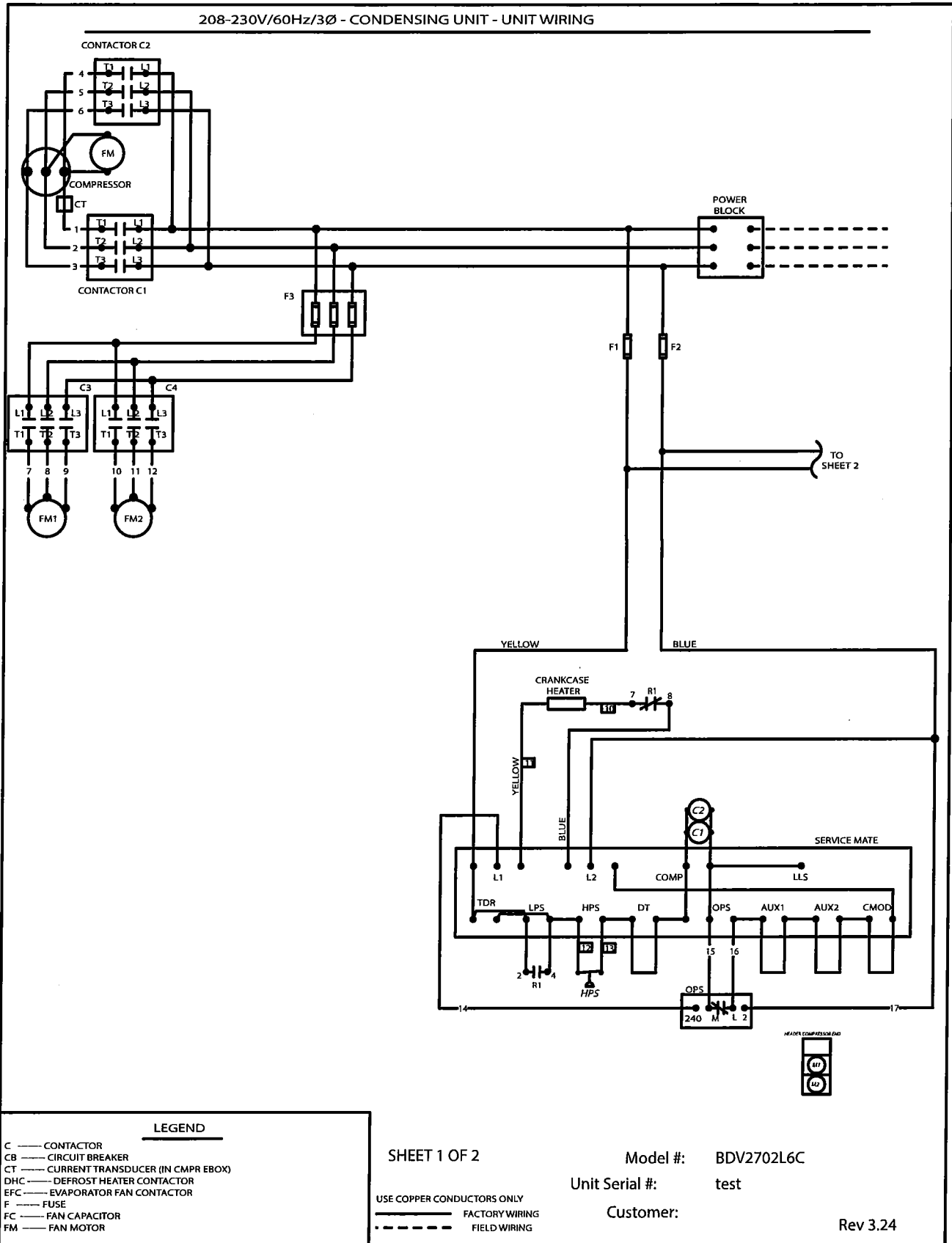

Wiring Diagram

(Standard Independent Evaporator Power Supply)

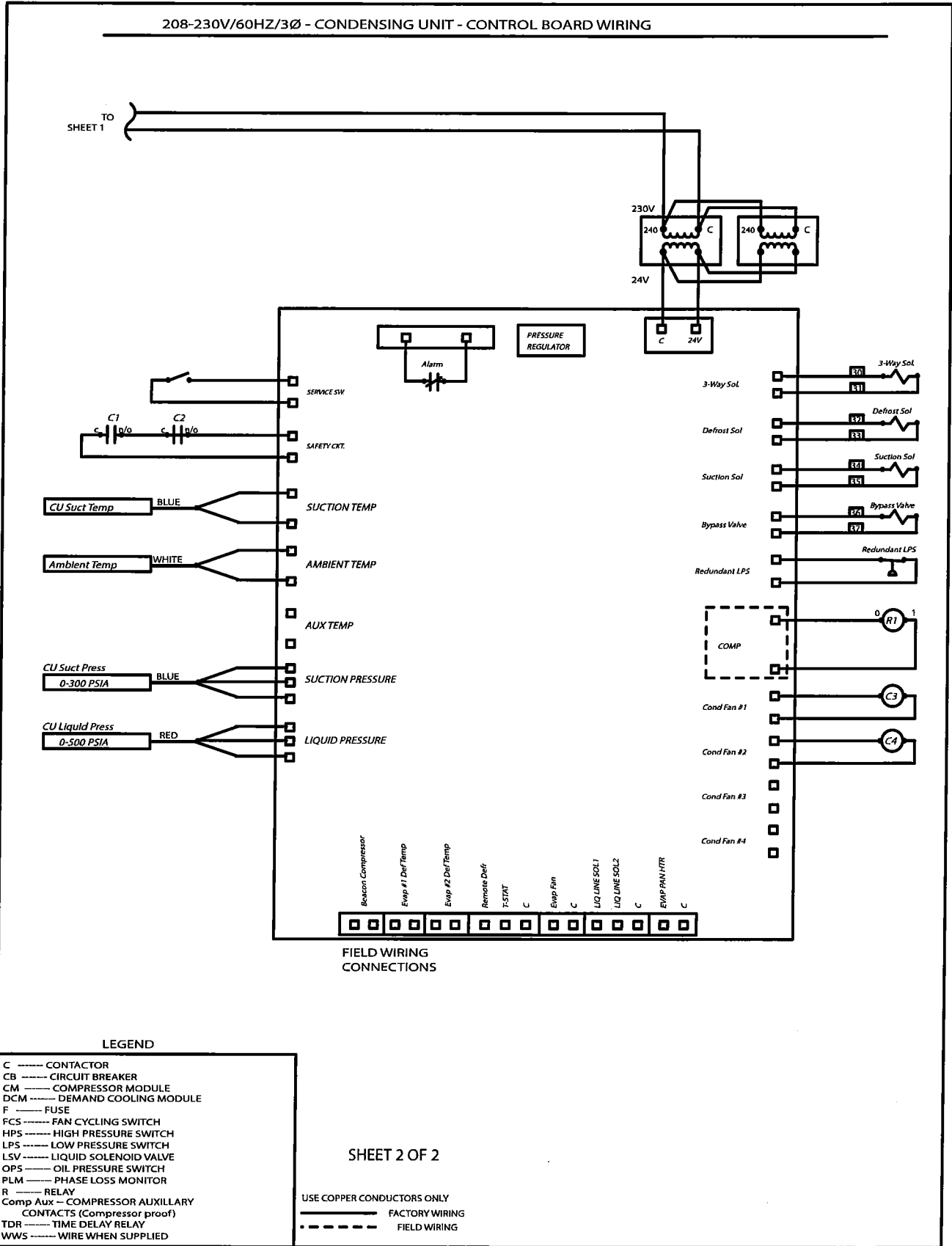

Wiring Diagram

(Standard Independent Evaporator Power Supply)

460V/60Hz/3Ø - CONDENSING UNIT - UNIT WIRING

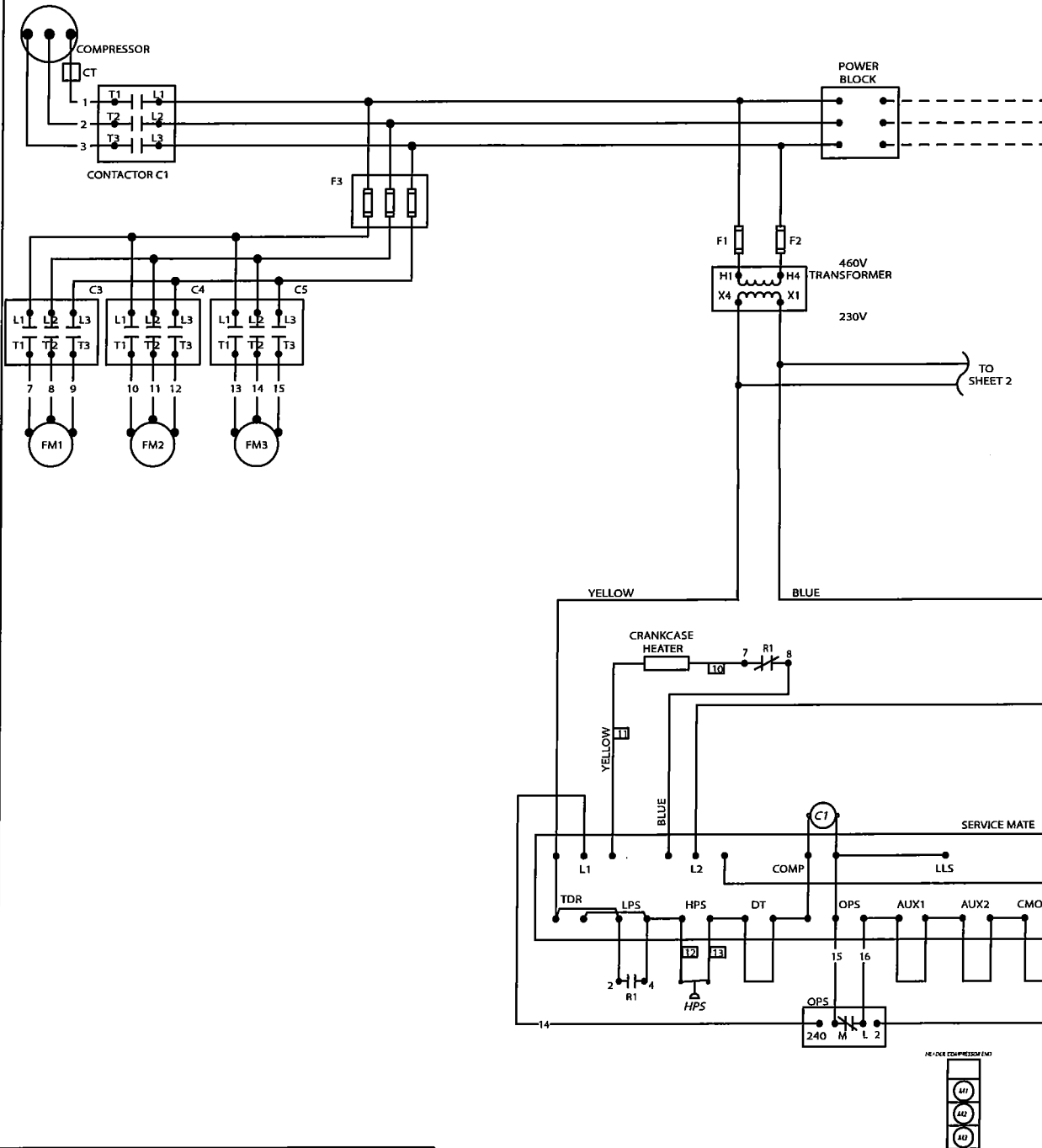

LEGEND

- C ----- CONTACTOR
- CB ----- CIRCUIT BREAKER
- CT ----- CURRENT TRANSDUCER (IN CMR EBOX)
- DHC ----- DEFROST HEATER CONTACTOR
- EFC ----- EVAPORATOR FAN CONTACTOR
- F ----- FUSE
- FC ----- FAN CAPACITOR
- FM ----- FAN MOTOR

SHEET 10F2

- USE COPPER CONDUCTORS ONLY
- FACTORY WIRING
- - - - - FIELD WIRING

Wiring Diagram

(Standard Independent Evaporator Power Supply)

460V/60HZ/3Ø - CONDENSING UNIT - CONTROL BOARD WIRING

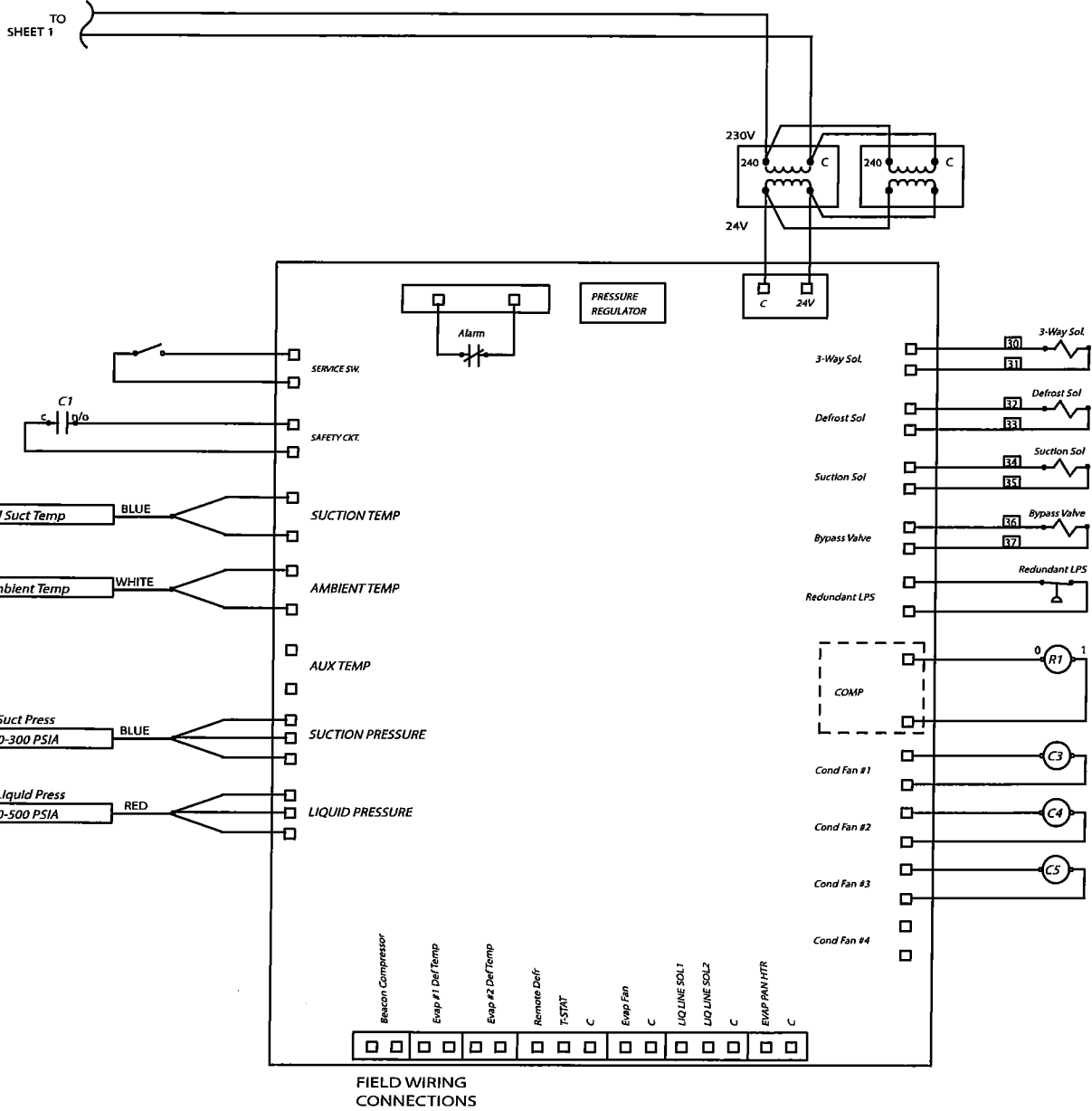

LEGEND

- C ----- CONTACTOR
- CB ----- CIRCUIT BREAKER
- CM ----- COMPRESSOR MODULE
- DCM ----- DEMAND COOLING MODULE
- F ----- FUSE
- FCS ----- FAN CYCLING SWITCH
- HPS ----- HIGH PRESSURE SWITCH
- LPS ----- LOW PRESSURE SWITCH
- LSV ----- LIQUID SOLENOID VALVE
- OPS ----- OIL PRESSURE SWITCH
- PLM ----- PHASE LOSS MONITOR
- R ----- RELAY
- Comp Aux -- COMPRESSOR AUXILIARY
- CONTACTS (Compressor proof)
- TDR ----- TIME DELAY RELAY
- WWS ----- WIRE WHEN SUPPLIED

SHEET 2 OF 2

- USE COPPER CONDUCTORS ONLY
- FACTORY WIRING
- - - - - FIELD WIRING

Wiring Diagram

(Standard Independent Evaporator Power Supply with VFD Condenser Fans)

460V/60Hz/3 ϕ - CONDENSING UNIT - UNIT WIRING

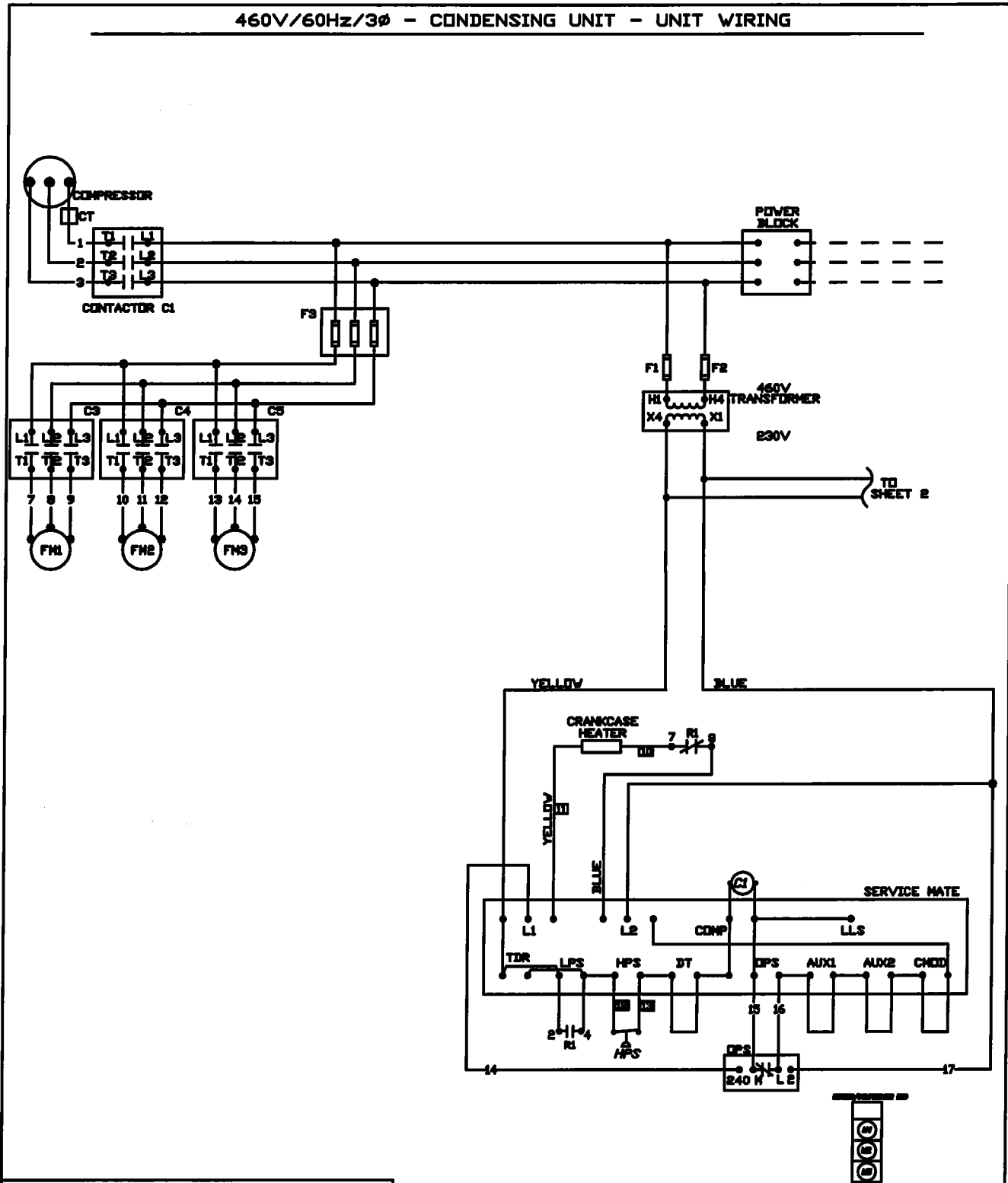

LEGEND	
C	CONTACTOR
CB	CIRCUIT BREAKER
CT	CURRENT TRANSUCER (IN CMR EDDO)
DHC	DEFROST HEATER CONTACTOR
EFC	EVAPORATOR FAN CONTACTOR
F	FUSE
FC	FAN CAPACITOR
FM	FAN MOTOR

SHEET 1 OF 2

USE COPPER CONDUCTORS ONLY

———— FACTORY WIRING

- - - - FIELD WIRING

Wiring Diagram

(Standard Independent Evaporator Power Supply with VFD Condenser Fans)

460V/60HZ/3Ø - CONDENSING UNIT - CONTROL BOARD WIRING

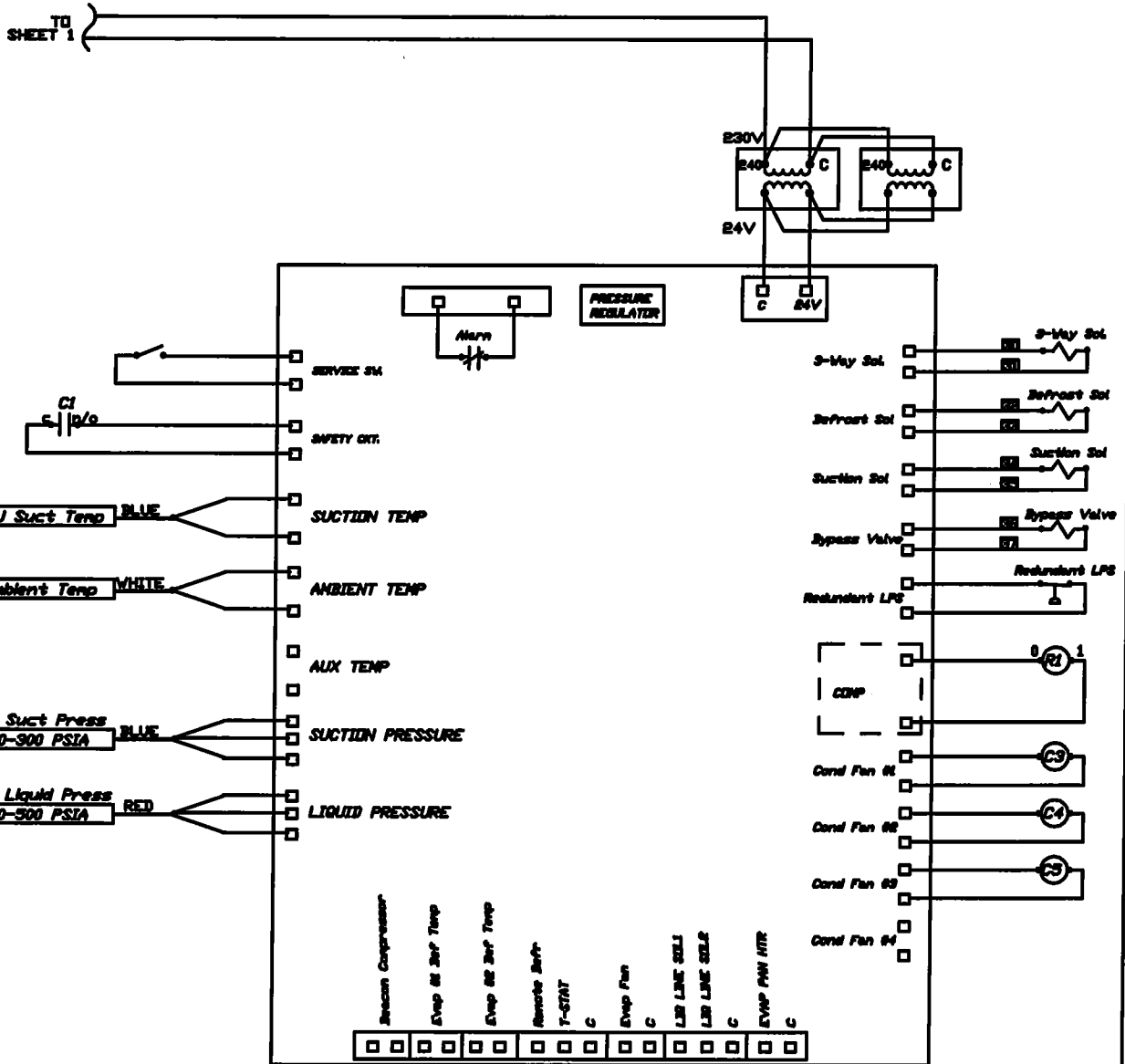

FIELD WIRING CONNECTIONS

LEGEND

- C ----- CONTACTOR
- CB ----- CIRCUIT BREAKER
- CM ----- COMPRESSOR MODULE
- DCM ----- DEMAND COOLING MODULE
- F ----- FUSE
- FCS ----- FAN CYCLING SWITCH
- HPS ----- HIGH PRESSURE SWITCH
- LPS ----- LOW PRESSURE SWITCH
- LSV ----- LIQUID SOLENOID VALVE
- LPS ----- OIL PRESSURE SWITCH
- PLM ----- PHASE LOSS MONITOR
- R ----- RELAY
- Comp Aux ----- COMPRESSOR AUXILIARY CONTACTS (Compressor proof)
- TDR ----- TIME DELAY RELAY
- VVS ----- WIRE WHEN SUPPLIED

USE COPPER CONDUCTORS ONLY
 ----- FACTORY WIRING
 - - - - - FIELD WIRING

SHEET 2 OF 2

Hot Gas Unit Cooler Typical Factory Piping

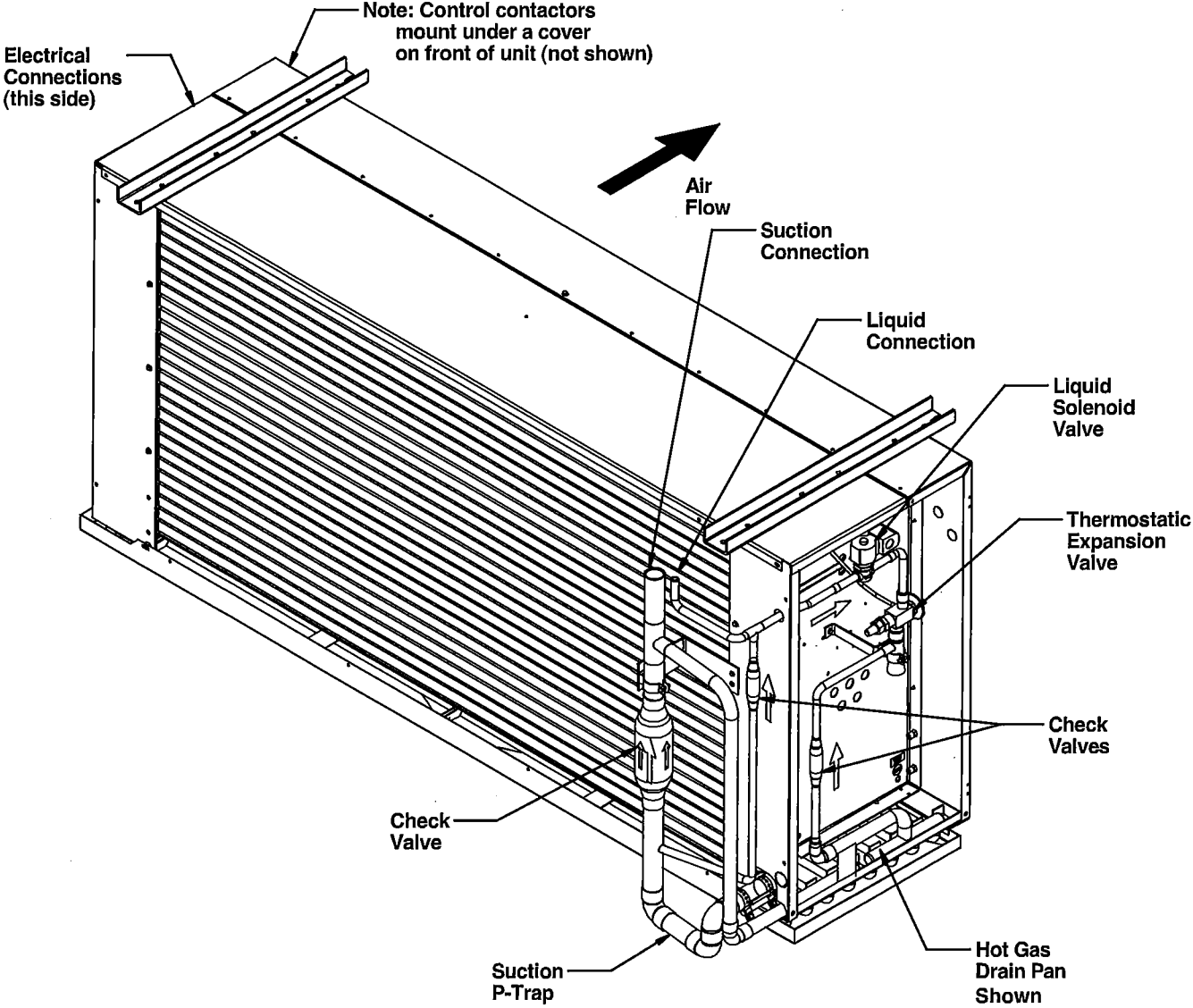

Hot Gas Condensing Unit Typical Factory Piping

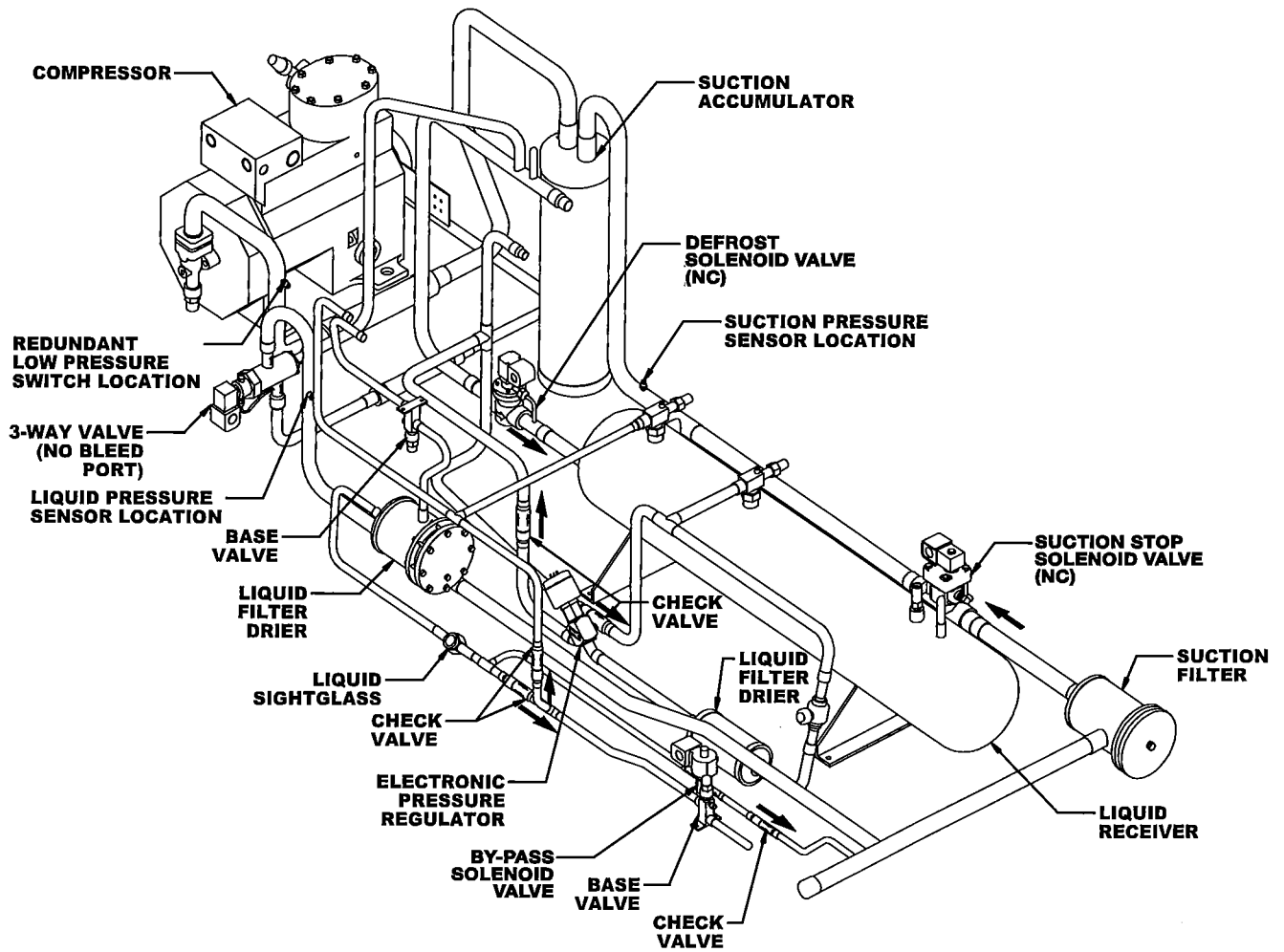

Refrigeration Operation

Refrigeration Operation

The refrigeration operation of the Mohave Hot Gas System is very similar to a standard refrigeration system. An external thermostat is connected to the hot gas control board at the terminal block connections labeled T-Stat and C (for common). When the normally open contact inside the thermostat closes (a call for cooling), the hot gas control board responds by activating a series of solenoids and contactors (described below) in order to initiate and maintain a refrigeration cycle. Later, when the thermostat contact opens, the hot gas control board deactivates the solenoids in a preset manner in order to safely turn off the refrigeration process and maintain an Off condition.

At initial power up, the system defaults to the *OFF* mode for a minimum of two minutes. Following the two-minute hold off period, the control circuit examines the state of the thermostat input. If the thermostat input signal is activated (closed between T-Stat and C), the system begins the refrigeration startup process. Full refrigeration mode (or *COLD* mode) is achieved when the control board has activated the solenoids necessary to provide refrigerant flow between the evaporator(s) and the condensing unit (Suction Solenoid and Liquid Line Solenoid), activated the compressor contactor, deployed the appropriate control over the condenser fans, and turned on the evaporator fans.

Refrigerant Solenoid and Compressor Contactor Control: The Suction Solenoid is initially activated following the power-up two-minute hold off time. It is maintained in the **ON** state until a defrost cycle is initiated. The timing of the liquid line solenoid (LLS) activation is based upon the saturated suction temperature (SST) which is calculated from the suction pressure value. If the SST is greater than 15°F, the compressor contactor is activated before the LLS is activated in order to decrease the suction pressure prior to startup. When the SST drops to -5°F, the LLS is activated. If the SST does not fall to -5°F within 2 minutes, *Err 12* is activated and the system goes to *OFF* mode.

If the SST is 15°F or less, the LLS is activated immediately. When the SST rises to -10°F for medium temperature applications or -20°F for low temperature applications, the compressor contactor is activated. If the SST fails to rise in 2 minutes, *Err 11* is activated and the system goes to *OFF* mode.

When the thermostat signal is deactivated, the liquid line solenoid is turned off immediately. The compressor contactor will stay activated until the suction pressure falls below the pre-programmed cut out pressure. The compressor contactor and all condenser fan contactors will be deactivated simultaneously. The evaporator fans will continue running.

Condenser Fan Control: When the Condensing Unit Model is selected in the Program Review Menu; the program automatically activates the default Head Pressure Control Scheme.

Method: Pressure Fan Cycling (*PRES*) All fans
Minimum condensing temperature: 65°F for medium temperature applications and 45°F for low temperature applications.

The default **ON** and **OFF** settings are optimized to maximize energy efficiency while still providing adequate pressure for the thermostatic expansion valve(s) to work properly. The parameters are refrigerant specific.

Fans are staged to minimize fluctuations in head pressure during operation.

During refrigeration operation, the hot gas controller monitors liquid pressure to determine if each fan should be **ON** or **OFF**.

These settings and other fan control options may be modified by turning on the Expert Mode (*XPERT*) in the Program Menu. See Program Review and Optional Controls for more information.

Evaporator Fan Control: After initial power-up, the evaporator fans will be turned off. When the system initiates the first cooling cycle, the hot gas controller monitors the temperature value of the evaporator defrost termination sensor mounted on the evaporator suction headers. When the controller determines that the suction header has reached the refreeze setpoint, the evaporator fans will be activated. If there are two evaporators, the fans will be energized by the first sensor to achieve setpoint. Once activated, the evaporator fans will continue to run until either a defrost cycle is initiated, or if the system is placed in **SERVICE** mode.

Anti Short-Cycle Protection: During cooling mode, the control board is programmed to allow a minimum system **ON** time of 1 minute and a minimum **OFF** time of 2 minutes.

Refrigeration Operation

Pump Down

At the end of each cooling cycle, when the box temperature is met, the hot gas control system will pump down and turn off the compressor.

To pump down, the Liquid Line Solenoid(s) is deactivated and the compressor runs until the pressure measured at the suction accumulator falls below the pre-programmed cut out pressure value, or two minutes has elapsed. The compressor is then turned off until the start of the next cooling cycle. During the pump down process, the LED display will show *PMP II*.

Manual Pump down: A single pole, single throw switch is connected to the Service SW input on the Hot gas control board. Activating this switch (closing the contact) will cause the system to pump down and shut off. While in Service mode, the evaporator fans will turn off. Note that the system will not restart until the switch contact has been opened. The hot gas controller will display *SERV* while in Service mode.

The system can also be pumped-down by pressing the **SERVICE** button twice. To restart the system, press the **CLEAR** button.

Black = Piping Inactive
Gray = Piping Active

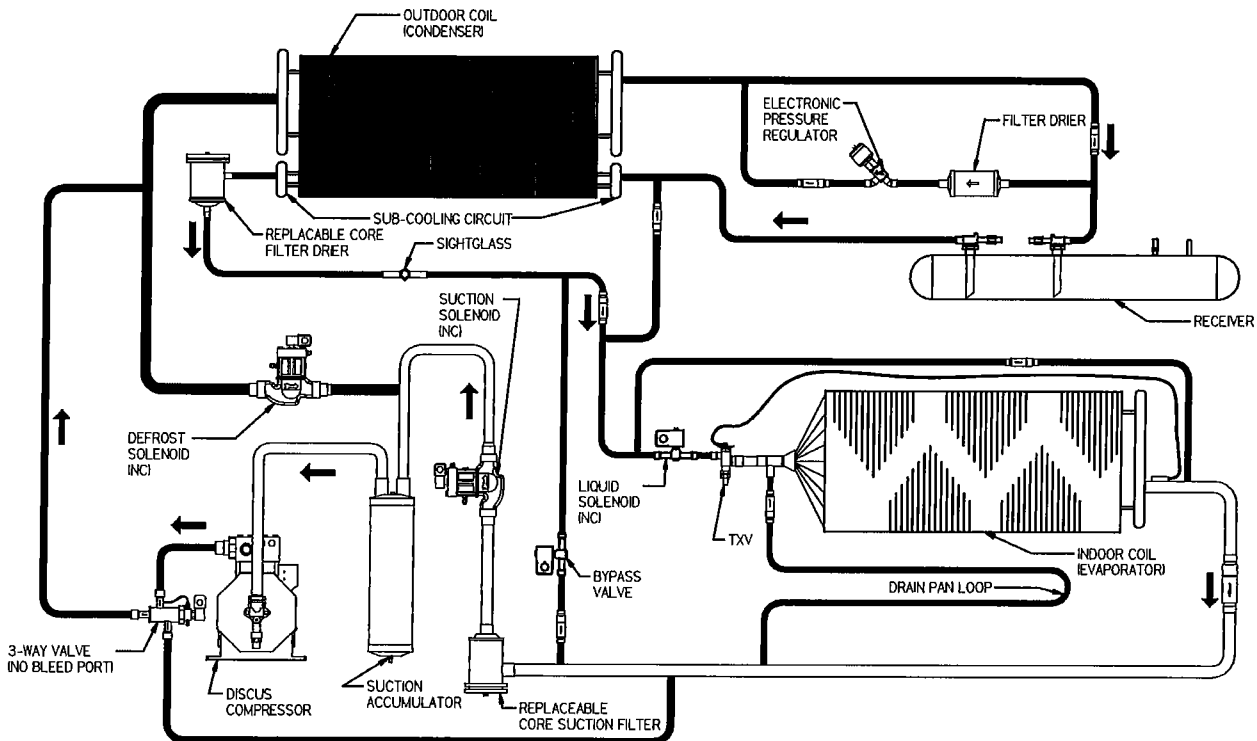

REFRIGERATION MODE

Defrost Operation

Defrost Operation

Defrost Timing/Schedule Programming

The hot gas controller can be programmed with up to 12 defrost start times. The Program Review menu section describes the process to program or delete a valid start time. Note that clearing a start time by pressing **CLEAR** and the **ENTER** will disable all start times following the one being cleared. There must be 30 minutes of elapsed time following a start of defrost before another defrost can be scheduled. A defrost cycle can be initiated manually at any time.

Force Defrost Manually

To manually force the start of a defrost-cycle, press the **FORCE DEFROST** button. If the system is in **Cool** mode, the system will pump down and go to the off mode before the defrost process is started.

Defrost Process

The defrost process has four steps: Pre-defrost (**DEF 1**) pressure equalization, Defrost operation (**DEF 2**), Post-defrost (**DEF 3**) pressure equalization and drain down, and Refreeze (**FREZ**).

DEF1:

Pre-defrost, or defrost step 1, always follows activation of Off mode. If the system is in Cool mode when the defrost cycle is activated, the control will pump down and go to Off mode before activating pre-defrost.

The purpose of **DEF 1** is to equalize the refrigerant pressures between the condensing unit receiver and the evaporator(s). This is accomplished by first deactivating the evaporator fans, and the suction solenoid. Next the Bypass Solenoid and the evaporator Pan Heater contactor are activated. The time duration of the pressure equalization is programmed as **EQU** in the **PROGRAM REVIEW** menu.

DEF2:

After the equalization time has elapsed, the Bypass Solenoid is deactivated. The Defrost Solenoid is activated 1 second later, followed by the 3-Way valve solenoid 1 second after that. Next, the pressure regulator control algorithm is enabled. The initial position is full open, but it quickly makes adjustments in order to stabilize the pressures and temperatures seen at the inlet of the suction accumulator.

The compressor contactor turns on at the same time that the pressure regulator is activated. The ambient temperature is measured, and a determination is made of how many condenser fans should be operating. The correct number of condenser fans is activated at the same time as the compressor contactor.

During the **DEF 2** operation, the pressure regulator continues to maintain the appropriate volume of refrigerant flow through the system based upon the current ambient conditions, the refrigerant type, and the type of cooling application.

Termination of defrost is accomplished by either both evaporators reaching their target termination temps, or the liquid pressure measured between the receiver and the condenser coil reaching its target pressure, or the pre-programmed fail safe time.

When one of the termination factors is realized, the compressor, condenser fan(s), and the defrost solenoid are turned off. The 3-Way valve and the Pan heaters are left on. The pressure regulator is activated to 100% open, and **DEF 3** begins.

DEF3:

Post-defrost has two purposes. The first is the transfer of high pressure refrigerant at the evaporator back to the condenser receiver by way of the pressure regulator. The pressure regulator is open 100% during this step. The second purpose is drain down time for the warm evaporators. This allows the water that was melted off of the coil to drain out of the evaporator drain pan. The time duration for this step is identical to the **DEF 1** equalization time.

After the completion of the delay time period, the 3-Way valve and the pan heater contactor are turned off. One second later the Suction Solenoid is turned on, and then one second after that the compressor turns on. The condenser fan control algorithm is also enabled. When the pressure measured at the suction sensor falls below -10°F SST, the liquid line solenoid is activated and the process step changes to Refreeze.

FREZ:

The Refreeze step is identical to Cooling mode except that the evaporator fans are turned off. This is to allow the evaporator coils to freeze any remaining water that might be left over from the drain down step so that when the fans turn on, the water will not be sprayed into the refrigerated space. When the evaporator reaches the refreeze set-point, or the refreeze time limit elapses, the fans turn on and the system begins a cooling cycle. If the thermostat is satisfied, or deactivated, the system will run a cooling cycle for two minutes and then pump down and shut off.

After the compressor is energized, the suction stop valve may be pulsed to limit the suction pressure at the compressor.

Through the refreeze period and into cooling mode, the liquid solenoid may energize and de-energize to hold the evaporator below 10 °F SST and allow the expansion valve to better regulate as the system enters cooling mode. Parameter LLSP controls the duration of this pulsing event.

Defrost Operation

Hot Gas Defrost Cycle Diagrams

Black = Piping Inactive
Gray = Piping Active

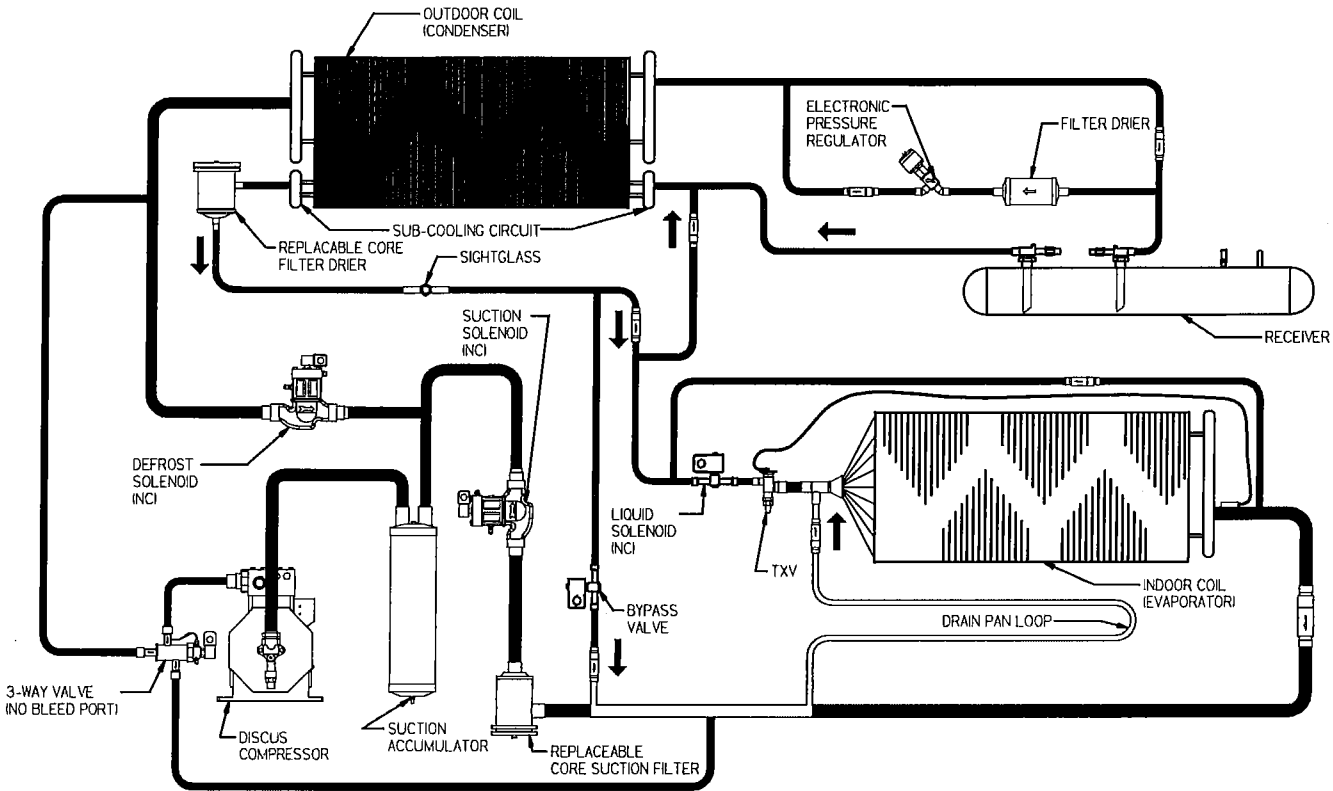

DEFROST-1 MODE

Defrost Operation

Hot Gas Defrost Cycle Diagrams

Black = Piping Inactive
Gray = Piping Active

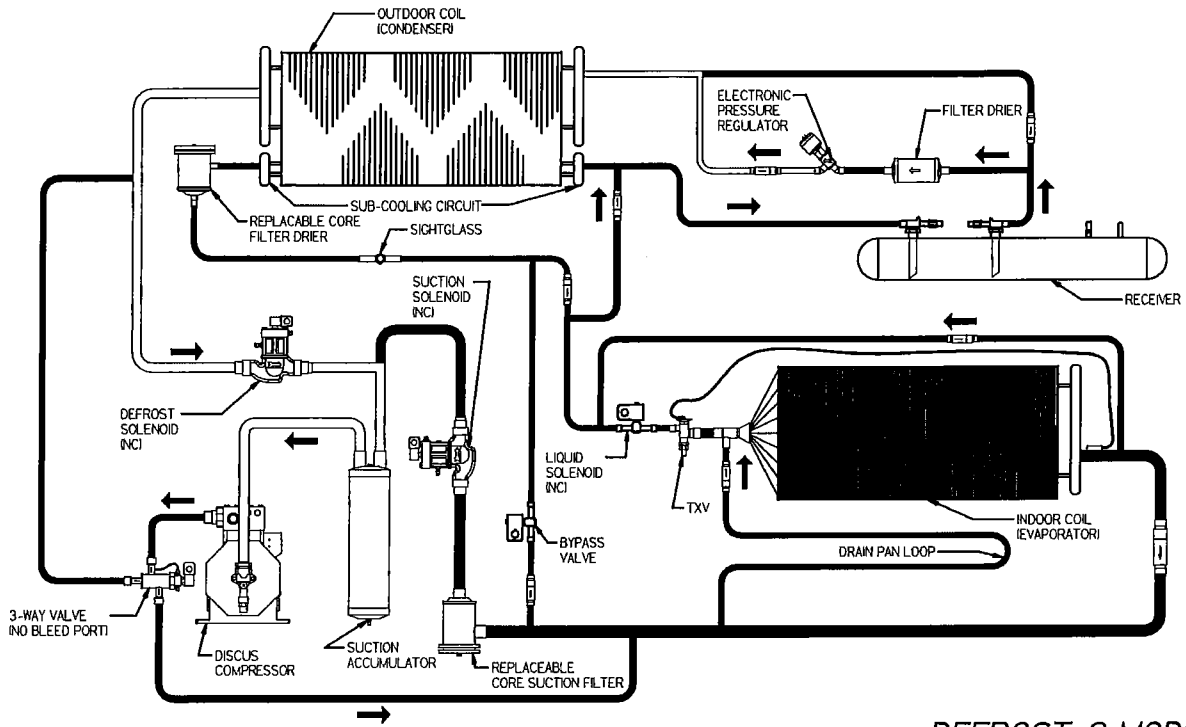

DEFROST-2 MODE

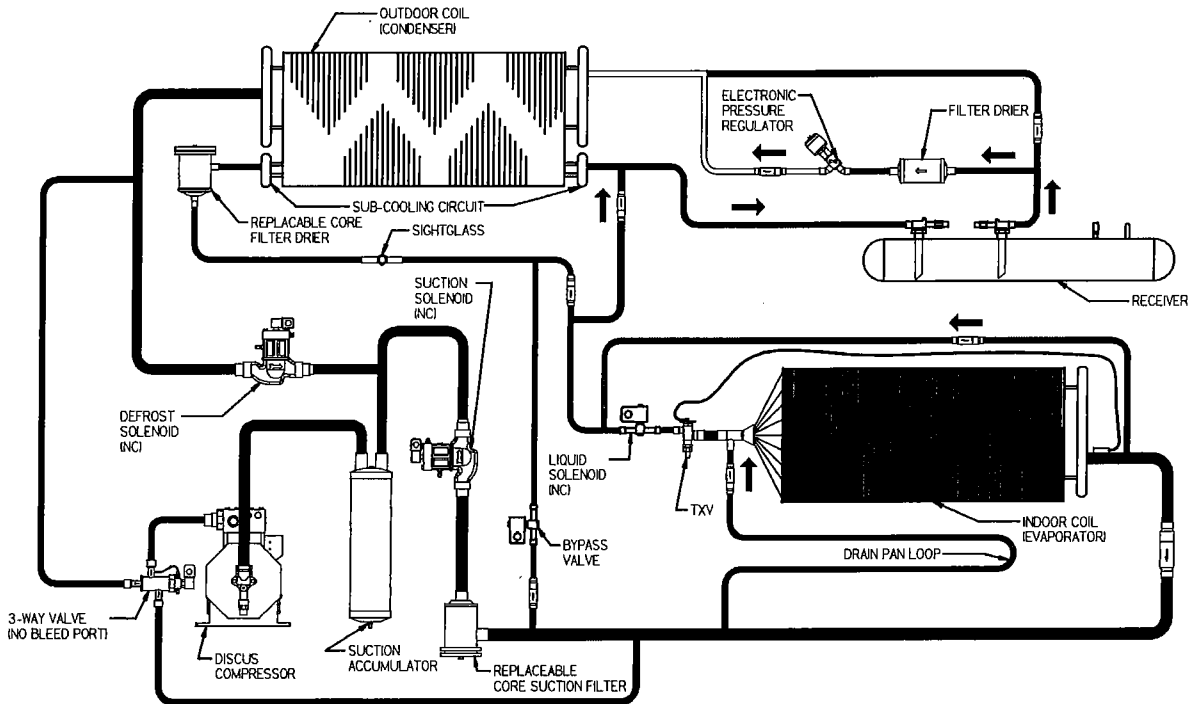

DEFROST-3 MODE

Defrost Operation

Defrost Termination Parameters

The hot gas controller uses a combination of temperature, pressure and time values to make the decision to end the defrost cycle. The Defrost Failsafe Time is used at all times to limit the length of defrost. At cool ambient temperatures, the controller checks both the temperature and pressure of the defrosting evaporator(s) before making a termination decision. In warm ambient temperatures, the Defrost Termination Pressure is used exclusively to insure that the evaporators remain in defrost for a sufficient length of time. When the controller is programmed, default temperature, pressure and time values are populated into settings. These default values were selected to fit the majority of applications. If necessary, these parameters may be accessed and changed in Expert Mode.

Defrost Skip Parameters

The hot gas controller monitors refrigeration operation for several situations that would indicate that a defrost cycle is unnecessary. In these situations, the controller will skip the next scheduled defrost.

Compressor run time is calculated since the last defrost cycle. If the run time is less than 30 minutes, the next defrost cycle is skipped.

When the measured saturated suction temperature is consistently above 32°F, the defrost cycle is skipped.

Evacuation & Leak Detection

Evacuation & Leak Detection

Due to the smaller molecule size of HFC's, they will tend to leak more readily than CFC's. Consequently, it is of the utmost importance that proper system evacuation and leak detection procedures be employed.

Copeland recommends a minimum evacuation to 500 microns. In addition, a vacuum decay test is strongly recommended to assure there is not a large pressure differential between the system and vacuum pump. Good evacuation processes include frequent vacuum pump oil changes and large diameter, short hose connections to both high and low sides of the system preferably using bronze braided hose.

Leak detection can be carried out in the conventional manner. If HCFC or CFC tracer gas is used, care must be taken to completely remove all traces of the gas prior to introducing HFC's.

Electronic leak detectors are now available that will sense HFC's. This is considered preferable since it removes the possibility of chlorine remaining in the system after leak testing with HCFC's and/or CFC's. There is a view that even small quantities of chlorine may act as a catalyst encouraging copper plating and/or corrosion and should therefore be avoided.

Within the last several years, manufacturers have developed fluorescent dye leak detection systems for use with refrigerants. These dyes mix with the lubricant and, when exposed to an ultraviolet light "fluoresce," indicates the location of leaks. Copeland has tested and approved the Rigid "System Safe" dye and found it to be compatible with the compressor materials in systems.

NOTE: *The Hot Gas Control Board may be powered up and set on "EVAC" Mode during Evacuation. In this mode, all of the system valves are energized. See Page 47.*

Leak Testing

After all lines are connected, the entire system must be leak tested. The complete system should be pressurized to not more than 150 psig with refrigerant and dry nitrogen (or dry CO₂). The use of an electronic type leak detector is highly recommended because of its greater sensitivity to small leaks. As a further check it is recommended that this pressure be held for a minimum of 12 hours and then rechecked. For a satisfactory installation, the system must be leak tight.

Line Insulation

After the final leak test, refrigerant lines exposed to high ambient conditions should be insulated to reduce heat pickup and prevent the formation of flash gas in the liquid lines. Suction lines must always be insulated with 3/4" wall Armstrong "Armaflex" or equal. When required, Liquid lines should be insulated with 1/2 inch wall insulation or better. The insulation located in outdoor environments should be protected from UV exposure to prevent deterioration of insulating value.

Evacuation

CAUTION: *Do not use the refrigeration compressor to evacuate the system. Do not start the compressor while it is in a vacuum.*

A good, deep vacuum pump should be connected to both the low and high side evacuation valves with copper tube or high vacuum hoses (1/4" ID minimum). If the compressor has service valves, they should remain closed. A deep vacuum gauge capable of registering pressure in microns should be attached to the system for pressure readings.

A shut off valve between the gauge connection and vacuum pump should be provided to allow the system pressure to be checked after evacuation. Do not turn off vacuum pump when connected to an evacuated system before closing shut off valve.

The vacuum pump should be operated until a pressure of 1,500 microns absolute pressure is reached — at which time the vacuum should be broken with the refrigerant to be used in the system through a drier until the system pressure rises above "0" psig.

NOTE: *Refrigerant used during evacuation cannot be vented. Reclaim all used refrigerant. EPA regulations are constantly being updated to ensure your procedure follows correct regulations.*

Repeat this operation a second time.

Open the compressor service valves and evacuate the entire system to 500 microns absolute pressure. Raise the pressure to 2 psig with the refrigerant and remove the vacuum pump.

Start-Up Operation and Program Review

Check Out and Start Up

After the installation has been completed, the following points should be covered before the system is placed in operation:

- (a) Check all electrical and refrigerant connections. Be sure they are all tight.
- (b) Observe compressor oil level before start-up. The oil level should be at or slightly above the 3/4 level of the sight glass. Refer to Table 7 on page 52 for proper compressor oil.
- (c) Remove upper mounting nuts on the compressor feet. Remove the shipping spacers. Install the neoprene washers onto the compressor feet. Replace the upper mounting nuts and washers, allowing 1/16" space between the mounting nut and the neoprene spacer.
- (d) Check high and low pressure controls, oil pressure safety controls, and all other safety controls, and adjust if necessary.
- (e) Check the room thermostat for normal operation and adjust.
- (f) Wiring diagrams, instruction bulletins, etc. attached to the condensing units should be read and filed for future reference.
- (g) All fan motors on air cooled condensers, evaporators, etc. should be checked for proper rotation. Fan motor mounts should be carefully checked for tightness and proper alignment.
- (h) Observe system pressures during charging and initial operation. Do not add oil while the system is short of refrigerant unless oil level is dangerously low.
- (i) Continue charging until system has sufficient refrigerant for proper operation. Do not overcharge. Remember that bubbles in a sight glass may be caused by a restriction as well as a shortage of refrigerant.
- (j) Do not leave unit unattended until the system has reached normal operating conditions and the oil charge has been properly adjusted to maintain the oil level between 1/2 and 1/4 of the sight glass.
- (k) Make sure all Schrader valve caps are in place and tight

CAUTION: Extreme care must be taken in starting compressors for the first time after system charging. At this time, all of the oil and most of the refrigerant might be in the compressor creating a condition which could cause compressor damage due to slugging. Activating the crankcase heater for 24 hours prior to start-up is required. If no crankcase heater is present, then directing a 500 watt heat lamp or other safe heat source on the lower shell of the compressor for approximately thirty minutes will be beneficial in eliminating this condition which might never reoccur.

Start-Up Operation - Initial Power On

At the initial application of power to the system, the compressor and the evaporator fans will be in a 2-minute hold-off cycle and will not start immediately. The 4-digit LED indicator located on the control board will display *OFF*. If the room thermostat setting is below the current room temperature, the contact inside the thermostat will be closed, and the associated T-Stat LED on the controller circuit board will be lit. Under these conditions, the system will begin a cooling cycle.

Operating Mode Display

<i>OFF</i>	Off Mode
<i>COOL</i>	Cooling Mode
<i>PMP</i>	Pump Down
<i>SERV</i>	Service Mode
<i>DELAY</i>	Delay Mode
<i>DEF1</i>	Pre-Defrost, or Bypass Mode
<i>DEF2</i>	Defrost Mode
<i>DEF3</i>	Post-Defrost Equalization, or Drain Mode
<i>TEST</i>	Test Mode

Programming and Reviewing Settings and Changes

The Program Review button is used to program, review and change all program settings for the system.

Press PROGRAM REVIEW button. The Setpoint item will appear on the LED. After a few seconds delay the Setpoint value will display. Each time the button is pressed a different item is displayed.

Next, use the SELECT knob to change value of Setpoint item.

Next, when the desired value is selected, press the ENTER button to place it in program memory. If the ENTER button is not pressed the value will not be stored in memory and thus will not be changed.

There are two levels of menu setting programs: Normal and Expert. The Expert settings are visible when the *XPR T* menu item is changed from Off to On.

Program Review (Items Available when in Normal Mode)

<i>CLKH</i>	Set the Time of Day clock hour value
<i>CLKM</i>	Set the Time of Day clock minute value
<i>F°/C</i>	Set Fahrenheit/Celsius temperature units (°F/°C)
<i>1224</i>	Set Time display method (12HR / 24HR)
<i>ALRT</i>	Set the Alarm Time (2 to 120 minutes)
<i>RTDF</i>	Defrost schedule based upon compressor runtime (OFF or Defrost based upon compressor runtime in 30 minute increments) Note that the time based menu choices below are disabled when RTDF is activated.
<i>DF01</i>	Set Defrost #1 starting time (12:00 to 12:00 in 30 minute increments)
<i>DF02</i>	Set Defrost #2 starting time
<i>DF03</i>	Set Defrost #3 starting time
<i>DF04</i>	Set Defrost #4 starting time
<i>DF12</i>	Set Defrost #12 starting time
<i>APPL</i>	Set Application type (MED, LOW)
<i>REFR</i>	Set Refrigerant type (R-22, R-404A, R-507, R-407A, R-407C, R-407F, R-448A and R-449A)
<i>MDL</i>	Set Condensing Unit Model Number
<i>XPR T</i>	Activate expert menu items (Off, On)

Program Review

Program Review (Items Available when in Expert Mode)

CLKH Set the Time of Day clock hour value
CLKM Set the Time of Day clock minute value
°F°C Set Fahrenheit/Celsius temperature units (°F/°C)
1224 Set Time display method (12HR. / 24HR)
ALRT Set the Alarm Time (2 to 120 minutes)
RDTF* ... Defrost time based upon compressor runtime (OFF or Defrost based upon compressor runtime in 30 minute increments) Note that the time based menu choices below are disabled when RDTF is activated.
DF01 Set Defrost #1 starting time (12:00 to 12:00. in 30 minute increments)
DF02 Set Defrost #2 starting time
DF03 Set Defrost #3 starting time
DF04 Set Defrost #4 starting time
DF12 Set Defrost #12 starting time
APPL*** Set Application type (MED, LOW)
REFR Set Refrigerant type R-22, R-404A, R-507, R-407A, R407C, R407F)
MDL Set Condensing Unit Model Number
XPR T Activate expert menu items (Off, On)
FAN 1 Set Fan #1 operation type (OFF, ON, PRES, AMBT)
FAN 2 Set Fan #2 operation type (OFF, ON, PRES, AMBT)
FAN 3 Set Fan #3 operation type (OFF, ON, PRES, AMBT)
FAN 4 Set Fan #4 operation type (OFF, ON, PRES, AMBT)
F1ON Set Fan #1 turn-on parameter (Only used if PRES or AMBT selected. PRES range is 110 psig to 300 psig, AMBT range is 30°F to 90°F).
F2ON Set Fan #2 turn-on parameter
F3ON Set Fan #3 turn-on parameter
F4ON Set Fan #4 turn-on parameter
F1OF Set Fan #1 turn-off parameter (Only used if PRES or AMBT selected. PRES range is 110 psig to 300 psig, AMBT range is 30°F to 90°F).
F2OF Set Fan #2 turn-off parameter
F3OF Set Fan #3 turn-off parameter
F4OF Set Fan #4 turn-off parameter
DF T 1 Set Evaporator #1 termination temperature (50°F to 100°F)
DF T 2 Set Evaporator #2 termination temperature (50°F to 100°F)
DEFP Set Defrost termination pressure (160 psig to 300 psig)
DEFT Set Defrost fail-safe time (5 minutes to 30 minutes)
EQU T Set defrost process equalizing time (1 to 10 minutes)
LPSH Set value of LPS cut-in value (0 psig to 30 psig)
LPSL Set value of LPS cut-out value (0 psig to 30 psig)
FZET Evaporator refreeze temperature (20°F to 40°F)
FZTM Evaporator refreeze maximum time (0 to 10 minutes)
VALM** .. Electronic pressure regulator manufacturer (Carel or Alco)
PRFS Electronic pressure regulator full scale
PRUI Electronic pressure regulator update rate (seconds)
DFID ... Electronic pressure regulator initial position (percent)
LLSP ... Liquid solenoid post defrost pulse period (0 to 15 minutes)
EVPF* ... Evaporator fans running during refrigeration off-cycle (OFF or ON)
ALRH Alarm room high temperature threshold in degrees
ALRL Alarm room low temperature threshold in degrees
AUXT Enable thermostat functionality via the auxiliary temperature sensor (ON/OFF)
BOX T Box set point when using the thermostat functionality from parameter AUXT (only appears when AUXT = ON)
MBAd Modbus address

Use the Program Review button to select these items:

Clock Hour setting – **CLKH** – Selection is made of the current hour. If 12 hour mode is selected, these values are displayed as 12:XX to 11:XX for the AM hours. The PM hours will be displayed with a decimal point following the minutes (12:XX.). If 24 hour mode is selected, the hours will run from 00:XX to 23:XX.

Clock Minute setting – **CLKM** – Selection is made of the current minute. The currently programmed time is displayed in the standard HH:MM format. Turning the potentiometer will cause the minute value to change between 00 and 59 minutes.

Degrees F/C setting – **°F°C** – Select units to display temperature. Fahrenheit or Celsius. Default: Fahrenheit.

Clock Time display setting – **12 24** – Selection is made of time display method. Use of 12-Hour technique is implemented by activating the last decimal place of the 4-character display when the time is indicating PM instead of AM values. Default: 12-Hour mode.

Alarm Time – **ALRT** – Time which the alarm elements conditions must exceed before alarm is triggered. Default: 20 minutes.

Defrost schedule method' - **RDTF** - Defrost may be schedules based upon clock time or compressor run time. For clock time, select OFF and schedule the desired defrost start times (from 0 to 12 defrosts per day). For compressor run time, select the amount of compressor run time (in refrigeration mode) to occur between defrost periods (from 30 minutes to 12 hours). Default: OFF

Defrost #1 Start Time – **DF01** – Programmed start time for defrost #1. Time value is displayed in HH.MM format. This time follows the 12/24 selection format. To disable the start time, press the **CLEAR/TEST** button and then press **ENTER**. All start times following the cleared time will become disabled. Default: 12.00

Defrost #2 Start Time – **DF02** - Programmed start time for defrost #2. Time value is displayed in HH.MM format. This time follows the 12/24 selection format. Default: 6.00

Defrost #3 Start Time – **DF03** - Programmed start time for defrost #3. Time value is displayed in HH.MM format. This time follows the 12/24 selection format. Default: 12.00.

Defrost #4 Start Time – **DF04** - Programmed start time for defrost #4. Time value is displayed in HH.MM format. This time follows the 12/24 selection format. Default: 6.00.

Defrost #5 to #12 Time – **DFXX** – These start times are preset to --.-- values and are disabled. To enable the start time, turn the blue knob to the desired time value and press the ENTER button.

Application Type – **APPL** – Selection is made for Medium Temp application or Low Temp application. Default: Medium Temp.

Refrigerant Type – **REFR** – Selection for type of refrigerant – R-22, R-404A, R-507, R-407A, R-407C, R-407F, R-448 and R-449A . Default is R-404A

Application Model Number – **MDL** – Selection is made to indicate which condensing unit model the circuit board is installed onto. The four digit number associated with the system capacity in BTU's is used. For example, a BDV1502M6 would have a numeric indication of '1502'. Turning the blue knob increments the choices available, pressing enter selects the currently displayed value. Default: 1502.

Expert Mode Menu Activation – **XPR T** – Selection is made to turn on or off the ability to view and modify specific menu items. Default: Off.

Note: all items listed below are only viewable when the Expert Mode option is turned on.

Program Review

Use the Program Review button to select these items:

Condenser Fan #x Operation Method – *FAN X* – Note that x represents a value between 1 and 4, and is selected in descending order following #1. Selection is made for type of fan operation control. Choices are: OFF, ON, PRES, and AMBT. The selection made will determine the parameter type of the operation ranges. Default: PRES.

Condenser Fan #x ON operation value – *F X ON* – Note that x represents a value between 1 and 4, and is selected in descending order following #1. This setting chooses the on value for the fan selected. When ON or OFF is chosen for a particular fan operation, this step will not be displayed. If *AMBT* was chosen, the value displayed is a temperature in °F. The temperature selection range is 30°F to 90°F. If *PRES* was selected, the value displayed represents a pressure in 'psig'. The pressure selection range is 110 psig to 300 psig.

Condenser Fan #x OFF operation value – *F x OF* – Note that x represents a value between 1 and 4, and is selected in descending order following #1. This setting chooses the off value for the fan selected. When ON or OFF is chosen for a particular fan operation, this step will not be displayed. If *AMBT* was chosen, the value displayed is a temperature in °F. The temperature selection range is 30°F to 90°F. If *PRES* was selected, the value displayed represents a pressure in 'psig'. The pressure selection range is 110 psig to 300 psig.

Defrost Termination Temp for Evaporator #1 – *DT 1* – This is the temperature as sensed from the evaporator suction line that is used to determine when the defrost cycle is complete. The value is displayed as a temperature. Default: 75°F (Low Temperature) 85°F (Medium Temperature)

Defrost Termination Temp for Evaporator #2 – *DT 2* – This is the temperature as sensed from the evaporator suction line that is used to determine when the defrost cycle is complete. The value is displayed as a temperature. Note: when two evaporators are used, both evaporator temperatures must reach their set point to terminate defrost. Default: Same as *DT 1*.

Defrost Termination Pressure – *DEFP* – Selection is made of the pressure value that will signify a complete defrost process. This decision is made in an 'OR' manner with the defrost termination temperature and the defrost failsafe time. That is, if any one of the defrost termination parameters is satisfied, the defrost will terminate. The value displayed is a pressure in 'psig' format. Default: 210 PSIG.

Defrost Failsafe Time – *DEFT* – This is the maximum time allowed for a coil to remain in defrost. Defrost will be terminated if the defrost end temperature measured at the evaporator(s) (both must be at temp if two evaporators) or the defrost end pressure is not attained when this time has expired. Default: 25 minutes.

Equalizing Time – *EQU T* – This is the duration time of the 'pre-defrost' pressure equalization process and the 'post-defrost' drain time. The selection range is 1 minute to 10 minutes. Default: 2 minutes.

Evaporator Refreeze Temperature – *FZET* – This is the evaporator temperature at which the fans energize after the refreeze (fan delay) period unless the maximum refreeze time is reached. The selection range is 20F to 40F.

Evaporator Refreeze Maximum Time - *FZTM* - This is the maximum time for the refreeze (fan delay) period. The selection range is 0 to 10 minutes.

Low Pressure Switch simulation 'Cut-In' value – *LPSH* – Selection is made of the 'cut-in' pressure value normally made on the mechanical low-pressure control switch. The value displayed is a pressure in 'psig' format. The pressure range is 0 psig to 30 psig.

Low Pressure Switch simulation Cut-Out value – *LPSL* – Selection is made of the 'cut-out' pressure value normally made on the mechanical low-pressure control switch. The value displayed is a pressure in 'psig' format. The pressure range is 0 psig to 30 psig.

Electronic Pressure Regulator Manufacturer - *VALM* - This parameter controls the Electronic Pressure Regulator Settings that are loaded for each corresponding application to match the installed valve (Carel or Alco). Default: Carel (CARL).

Electronic Pressure Regulator - *PRFS, PRUI, DFIO* - These parameters control the operation of the pressure regulator during the defrost period and the default selections are tuned to specific condensing unit models. Field modification is not recommended. Default: See table of factory default settings.

Liquid solenoid pulse feature - *LLSP* - In the period immediately after defrost, the evaporator fans will energize and the liquid solenoid valve may be pulsed to reduce the evaporating temperature and give the warm thermostatic expansion valve additional time to close. This feature will function primarily on medium temperature systems and is adjustable from 0 to 15 minutes. Default: 5 minutes.

Evaporator fan run operation¹ - *EVPF* - This parameter controls the status of the evaporator fans during the refrigeration off-cycle when the thermostat is satisfied. (On or OFF) Default: On.

High auxiliary temperature alarm – *ALHR* – This parameter is the temperature set point that when measured above by the auxiliary temperature sensor will cause an ALR5 alarm after the alarm time has been exceeded. Default: OFF.

Low auxiliary temperature alarm – *ALRL* – This parameter is the temperature set point that when measured below by the auxiliary temperature sensor will cause an ALR6 alarm after the alarm time has been exceeded. Default: OFF.

Auxiliary temperature sensor thermostat control – *AUX T* – This parameter will allow the auxiliary temperature sensor to be used as a box thermostat control. Auxiliary temperature sensor can be extended up to 500ft using 18 gauge wire. There is no alarm provision for an auxiliary sensor failure and an external box temperature alarm is recommended if this functionality is desired. When used for box thermostat functionality setting the low and high temperature alarms (parameters ALRL, ALRH) is recommended. The recommended location of the auxiliary temperature sensor for box thermostat control is on the Inlet air side of the evaporator. Default: OFF.

Box thermostat set point – *BOX T* – This parameter is the box temperature, or room temperature, set point that the Mohave board will control to using the auxiliary temperature sensor if parameter AUXT is enabled. There is a non-changeable 1 degree differential around this set point for refrigeration operation. This parameter will only appear in the menu if *AUX T* is enabled. Default 35 degrees Fahrenheit. The box thermostat set-point range is -25°F to 50°F.

Modbus address - *MBA d* - multiple Mohave control boards may be connected via Modbus RS-485, which allows monitor menu functions and system status to be viewed. This setting allows each board to be addressed uniquely (1 to 50). Default: 1. Consult Heatcraft application engineering for further support.

NOTE: *Available on Software version V1.04 and higher
**Available on Software version V1.06 and higher
***Menu Re-Ordered on Software version V2.05 and higher

Monitoring and Reviewing Operation Values

Reviewing Operation Values

The Monitor button is used to examine and review the current operating conditions of the system.

Press **MONITOR** button. A descriptive abbreviation of the item will appear on the LED. After a few seconds delay the current value of the item will display. Each time the button is pressed a different item is displayed.

Monitor Button Items

VRLPDefrost Regulator Valve percent of opening (0 to 100%)
SUPHSuperheat (°F) measured at inlet of Suction Accumulator
SUCTSuction Temperature (°F) at inlet of Suction Accumulator
SUCPSuction Pressure (PSIG/HG) at inlet of Suction Accumulator
SSUCSaturated Suction Temperature (°F)
LIDPLiquid Pressure measured between CU Receiver and Condenser
AMBTAmbient Temperature (°F) measured at condenser coil
AUXTAuxiliary Temperature (°F)
E1DTEvaporator #1 Defrost Termination Temp (°F)
E2DTEvaporator #2 Defrost Termination Temp (°F)
ACINControl Board voltage (24VAC nominal)
TMMSCurrent time minutes-seconds
TMMHCurrent time hours-minutes
CCYCCompressor cycles since midnight
RnTMCompressor run time since midnight
DFTMDuration of last defrost
ETLDElapsed time since last defrost
RTL DRun time since last defrost
VERSSoftware version

Force Defrost

To force a 'defrost', press the **FORCE DEFROST** button. The system will pump-down and shut off the compressor. The system will activate the solenoids required for the 'pre-defrost' bypass operation, and a defrost will commence as described in a later section. The display will show *DEF 1*.

Reset Time

Pressing this button will reset the time clock in the microprocessor to zero. At initial power up, pressing this button will bypass the two minute hold off and the system will start immediately after a valid 'T-stat' signal is recognized. The display will show *DELAY*.

Force Service

Pressing this button TWICE will cause the system to pump down and the compressor to shut off. The system will remain off until the **CLEAR** button is pressed. When the system is initially placed into **FORCE SERVICE** mode, the display will show *SERV*.

While in 'Service mode', individual outputs may be activated by selecting the desired output circuit and pressing the **ENTER** button. The output circuit is selected by turning the blue knob. Turning the blue knob completely counter-clockwise selects *EVPF* or evaporator fans.

Forced Output Items

These items are displayed as the blue knob is turned in a clockwise direction. Turning the knob counter clockwise reverses the order. Pressing **ENTER** will activate the displayed item.

EVPFEvaporator Fan Contactor
LIDSLiquid Line Solenoid
EVPHEvaporator Pan Heater
FAN4Condenser Fan #4 Contactor
FAN3Condenser Fan #3 Contactor
FAN2Condenser Fan #2 Contactor
FAN1Condenser Fan #1 Contactor
COMPCompressor Contactor
BYPVBypass Solenoid
SUCSSuction Stop Solenoid
DEFSDefrost Solenoid
3WAY3-Way Valve Solenoid
ALRMAlarm Contacts
VALSRegulator Valve control
EVACEvacuate System Mode

Pressing **ENTER** when *VALS* is selected causes the number 0 to be displayed. This represents the percentage of regulator valve opening. Turning the blue knob will increase or decrease this number until a desired setting is made. Press the **ENTER** button to force the regulator to change to the desired setting.

CLEAR/TEST Button

Pressing this button ONCE will return the LED display to the default display. With the system in the *OFF* mode, pressing this button will activate the *TEST* mode. In the *TEST* mode, the controller will activate the outputs one at a time starting with the evaporator fans for 4 seconds per output. The sequencing will continue until the **CLEAR** button is pressed again.

Status Indicator Led

A red, four digit, alphanumeric LED on the hot gas control board indicates status, alarms, and error codes.

LED Display

Mode

<i>OFF</i>	Off
<i>COOL</i>	Cooling
<i>DELY</i>	Delay
<i>PMP D</i>	Pump Down
<i>DEF 1</i>	Pre-Defrost Bypass
<i>DEF 2</i>	Defrost
<i>DEF 3</i>	Drain down
<i>FREZ</i>	Refreeze
<i>TEST</i>	Test
<i>SERV</i>	Service

Error and Alarm Details

Alarms

<i>Alr 1</i>	Persistent input sensor/transducer failure
<i>Alr 2</i>	Combined Err4 and Err8, system off
<i>Alr 3</i>	Repeated Safety Circuit Open condition
<i>Alr 4</i>	Prolonged cooling startup failure
<i>Alr 5</i>	High auxiliary temperature sensor alarm
<i>Alr 6</i>	Low auxiliary temperature sensor alarm.

NOTE: An Alarm Activation turns on the Alarm Relay and LED

Errors

<i>Err 1</i>	Suction temperature sensor open or short
<i>Err 2</i>	Ambient temp sensor open or short
<i>Err 3</i>	Auxiliary temp sensor open or short
<i>Err 4</i>	Suction Pressure sensor open or short
<i>Err 5</i>	Liquid Pressure sensor open or short
<i>Err 6</i>	Evap 1 defrost temp sensor open or short
<i>Err 7</i>	Evap 2 defrost temp sensor open or short
<i>Err 8</i>	Redundant low pressure switch open or short
<i>Err 9</i>	Safety Circuit interruption during normal operation
<i>Err 10</i>	Prolonged Low Suction Pressure during cooling
<i>Err 11</i>	Low Suction Pressure startup failure
<i>Err 12</i>	High Suction Pressure startup failure
<i>Err 13</i>	Post Defrost pump down error

Component Errors - Alr1

During operation, the hot gas control board examines each input device to determine if its signal falls within a preset operational window. When the input device fails, the control board identifies the member by flashing an error code on the LED display. If the signal is restored to normal parameters, the error code is immediately removed.

If the error persists for the amount of time programmed in step *ALRT* of the Program Review menu, Alarm #1 will activate. Alarm 1 causes the Alarm Relay and the alarm LED to turn on, **it does not shut the system down.**

When one of the input sensors fail, the hot gas controller will adjust its decision making process to accommodate the loss. These adjustments are referred to as contingencies and are stop-gap measures to keep the system running until the failed component can be replaced.

Shut down Error - Alr2

If the suction pressure sensor fails (*Err 4*, *Alr 1*), the redundant low pressure switch is used to operate the system during refrigeration until the pressure sensor can be replaced. If the redundant low pressure switch also fails (*Err 8*), the system will stop operating and display *Alr 2*.

If the pressure sensor is replaced, the system will begin operating again normally. If the pressure switch is replaced, the system will operate under the *Err 4*, *Alr 1* constraints.

Component Errors - Alarm 1 - Contingency Chart

Component	Error #	Contingency
Suction Temperature Sensor Open or Short	<i>Err 1</i>	Regulator control during defrost will be by pressure only
Ambient Temperature Sensor Open or Short	<i>Err 2</i>	Condenser fans configured for ambient control will cycle with compressor
Suction Pressure Sensor Open or Short	<i>Err 4</i>	Medium temperature systems will air defrost*, low temperature systems will refrigerate as long as possible without defrost. Redundant low pressure switch used to control refrigeration
Liquid Pressure Sensor Open or Short	<i>Err 5</i>	Condenser fans configured for pressure control will cycle with the compressor; defrosts will terminate by evap temperature
Evap 1 Defrost Temperature Sensor Open or Short	<i>Err 6</i>	Two evap systems will use other evap sensor or system will pressure terminate defrost, refreeze will be time value
Evap 2 Defrost Temperature Sensor Open or Short	<i>Err 7</i>	Two evap systems will use other evap sensor or system will pressure terminate defrost, refreeze will be time value
Redundant Low Pressure Switch Malfunction Detected	<i>Err 8</i>	System will operate normally, this is a back-up device

*DEFA Displayed in this Mode

Safety Circuit Interruption - Alr3

If the safety circuit input signal is broken during normal refrigeration or defrost, *Err 9* is displayed. This failure is caused when one of the components connected to the Service Mate™ such as the oil pressure switch or the high pressure switch opens unexpectedly.

The hot gas controller will wait 4 minutes and attempt to restart the interrupted process. If successful, the error is cleared. If unsuccessful, the system will shutdown again and try to restart later. If the problem persists, *Alr 3* will be activated.

Failure to Start Errors - Alr4

Normal start up processes for cooling mode requires a specific pressure range to be present at the suction pressure sensor. If the measured pressure is too high or too low, steps are taken to cause the pressure to adjust before full cooling mode can be achieved. If these methods are not successful within 2 minutes, *Err 11* (for a pressure too low) or *Err 12* (for a pressure too high) is displayed. The system will continue trying to start every four minutes. If the error persists for the amount of time programmed in step *ALRT*, *Alr 4* will be activated.

Box Thermostat (Feature Enabled) Limits Exceeded - Alr5, Alr6

High auxiliary temperature sensor alarm - *ALRS*: This alarm energizes the alarm relay output if the measure auxiliary temperature sensor value is above the *ALRH* set point for a length of the *ALRT* time, and de-energizes the alarm relay output immediately when the temperature is no longer above the *ALRH* set point.

Low auxiliary temperature sensor alarm - *ALRE*: This alarm energizes the alarm relay output if the measured auxiliary temperature sensor value is below the *ALRL* set point for a length of the *ALRT* time, and de-energizes the alarm relay output immediately when the temperature is no longer below the *ALRL* set point.

Persistent Low Suction Pressure - Er10

When the measured suction pressure falls to 0 psig or less, the system will shut down and display *Err 10*. The duration of time that is allowed is dependent on the measured ambient temperature. If the ambient temperature is above 20°F, the shut down is immediate. If the ambient is 20°F or less, the low pressure condition must persist for 15 seconds before the error is identified.

Suction Pressure Fails to Drop Following Defrost or Cooling, ER12, ER13

If the suction pressure does not drop after 4 minutes of operation following the defrost 3 period, *Err 13* is displayed. This will not cause an alarm condition because the system will begin attempting to start a cooling cycle 4 minutes later, and the high pressure start-up fault (*Err 12*) will take over.

Refrigerant Charging

Refrigerant Charging Instructions

1. Install a liquid line drier in the refrigerant supply line between the service gauge and the liquid service port of the receiver. This extra drier will insure that all refrigerant supplied to the system is clean and dry.
2. When initially charging a system that is in a vacuum, liquid refrigerant can be added directly into the receiver tank.
3. Check serial data tag attached to the unit for refrigerant capacity (if special application). Maximum system refrigerant capacity is 90% of receiver capacity. Do not add more refrigerant than the data tag indicates, unless the line run exceeds 25ft. Then, additional refrigerant may be added as per the chart on page 20. Weigh the refrigerant drum before charging so an accurate record can be kept of the weight of refrigerant put in the system. See adjacent table for Standard Receiver Capacities.
4. Start the system and finish charging until the sight glass indicates a full charge and the proper amount has been weighed in. If the refrigerant must be added to the system through the suction side of the compressor, charge in vapor form only. Liquid charging must be done in the high side only or with liquid metering devices to protect the compressor.

Charge Quantity and Condenser Fan Control

The method of head pressure control affects refrigerant charge and the staging of the condenser fans. The system should have the minimum charge necessary to allow for proper operation at all expected conditions. Condenser fan control settings should balance system efficiency with fan motor power consumption. Stable pressures during refrigeration are another important consideration. The following guidelines are intended to support these goals.

Receiver Capacities and Head Pressure Valve Flooding Charges

Additional Refrigerant Charge (Lbs) Required for Various Evaporating Temperatures (SST)

Legacy Medium Temperature Model Refrigerant Charges

MODEL/ REFRIG	MODEL SIZE	(90%) RECEIVER CAPACITY Lbs	Condenser Flooding Charge, Lbs			
			20F SST -20F AMB	10F SST -20F AMB	20F SST 20F AMB	10F SST 20F AMB
M6 (R404A/R507)	752, 762	81	15	16	13	14
M6 (R404A/R507)	802	81	20	21	17	19
M6 (R404A/R507)	1002, 1202	81	27	29	24	25
M6 (R404A/R507)	1502, 2002	123	45	47	39	42
M6 (R404A/R507)	2502	123	67	71	59	63
M6 (R404A/R507)	3002	188	67	71	59	63
M6 (R404A/R507)	3502	188	89	95	78	84
M6 (R404A/R507)	4002	188	84	90	74	79
M6 (R407A,C,F)	752, 762	88	17	18	15	16
M6 (R407A,C,F)	802	88	22	23	19	20
M6 (R407A,C,F)	1002, 1202	88	30	31	26	28
M6 (R407A,C,F)	1502, 2002	135	49	52	43	46
M6 (R407A,C,F)	2502	135	73	78	64	69
M6 (R407A,C,F)	3002	205	73	78	64	69
M6 (R407A,C,F)	3502	205	98	104	86	92
M6 (R407A,C,F)	4002	205	92	98	81	87
M6 (R448A/449A)	752, 762	85	16	17	14	15
M6 (R448A/449A)	802	85	21	22	19	20
M6 (R448A/449A)	1002, 1202	85	29	31	25	27
M6 (R448A/449A)	1502, 2002	131	47	50	42	45
M6 (R448A/449A)	2502	131	71	76	63	67
M6 (R448A/449A)	3002	199	71	76	63	67
M6 (R448A/449A)	3502	199	95	101	83	89

Refrigerant Charging

Meet Minimum AWEF Medium Temperature Model Refrigerant Charges

MODEL/ REFRIG	MODEL SIZE	(90%) RECEIVER CAPACITY Lbs	Condenser Flooding Charge, Lbs			
			20F SST -20F AMB	10F SST -20F AMB	20F SST 20F AMB	10F SST 20F AMB
MT (R404A/R507)	0077, 0078	123	62	62	60	60
MT (R404A/R507)	0082, 0102, 0122	123	83	83	79	79
MT (R404A/R507)	0152	123	62	62	59	59
MT (R404A/R507)	0202	123	83	83	79	79
MT (R404A/R507)	0252	123	92	92	88	88
MT (R404A/R507)	0302	188	92	92	88	88
MT (R404A/R507)	0352	188	123	123	118	118
MT (R404A/R507)	0402	188	122	122	117	117
MT (R407A,C,F)	0077, 0078	128	64	64	62	62
MT (R407A,C,F)	0082, 0102, 0122	128	86	86	82	82
MT (R407A,C,F)	0152	128	64	64	61	61
MT (R407A,C,F)	0202	128	86	86	82	82
MT (R407A,C,F)	0252	128	96	96	92	92
MT (R407A,C,F)	0302	196	96	96	92	92
MT (R407A,C,F)	0352	196	127	127	122	122
MT (R407A,C,F)	0402	196	127	127	122	122
MT (R448A/449A)	0077, 0078	129	65	65	62	62
MT (R448A/449A)	0082, 0102, 0122	129	87	87	83	83
MT (R448A/449A)	0152	129	65	65	62	62
MT (R448A/449A)	0202	129	87	87	83	83
MT (R448A/449A)	0252	129	97	97	92	92
MT (R448A/449A)	0302	197	97	97	92	92
MT (R448A/449A)	0352	197	129	129	123	123
MT (R448A/449A)	0402	197	128	128	123	123

Refrigerant Charging

Legacy Low Temperature Model Refrigerant Charges

MODEL/ REFRIG	SIZE	(90%) RECEIVER CAPACITY Lbs	Condenser Flooding Charge, Lbs			
			-5F SST -20F AMB	-25F SST -20F AMB	-5F SST 20F AMB	-25F SST 20F AMB
L6 (R404A/R507)	0602, 0752	81	16	17	14	16
L6 (R404A/R507)	0902, 1002, 1202	81	21	22	19	21
L6 (R404A/R507)	1502	81	28	30	26	28
L6 (R404A/R507)	2202	123	47	50	42	47
L6 (R404A/R507)	2702, 3002	123	65	69	59	65
L6 (R407A,F)	0602, 0752	88	17	18	16	17
L6 (R407A,F)	0902, 1002, 1202	88	23	24	21	23
L6 (R407A,F)	1502	88	31	33	28	31
L6 (R407A,F)	2202	135	51	54	46	51
L6 (R407A,F)	2702, 3002	135	71	75	65	71
L6 (R448A/449A)	0602, 0752	85	17	18	15	17
L6 (R448A/449A)	0902, 1002, 1202	85	22	23	20	22
L6 (R448A/449A)	1502	85	30	32	27	30
L6 (R448A/449A)	2202	131	50	53	45	50
L6 (R448A/449A)	2702, 3002	131	69	73	63	69

Meet Minimum AWEF Low Temperature Model Refrigerant Charges

MODEL/ REFRIG	SIZE	(90%) RECEIVER CAPACITY Lbs	Condenser Flooding Charge, Lbs			
			-5F SST -20F AMB	-25F SST -20F AMB	-5F SST 20F AMB	-25F SST 20F AMB
LT (R404A/R507)	0062	123	65	65	63	63
LT (R404A/R507)	0077, 0092,0102,0122	123	87	87	83	83
LT (R404A/R507)	0152, 0222, 0272,0302	123	86	86	83	83
LT (R407A,F)	0062	128	68	68	65	65
LT (R407A,F)	0077, 0092,0102,0122	128	90	90	86	86
LT (R407A,F)	0152, 0222, 0272,0302	128	89	89	86	86
LT (R448A/449A)	0062	129	68	68	66	66
LT (R448A/449A)	0077, 0092,0102,0122	129	91	91	87	87
LT (R448A/449A)	0152, 0222, 0272,0302	129	90	90	87	87

Refrigerant Charging

Systems with Pressure Fan Cycling for Head Pressure Control (Standard)

For these systems the general recommendation is to use a clear sight glass as an indication of proper refrigerant charge, then add another 10% to compensate for liquid pressure changes during fan cycling. During cooler ambient temperatures the fan cycle settings should be temporarily changed to yield a 105°F minimum condensing temperature during the charging process. An alternate method is to temporarily block a portion of the entering air condenser surface to restrict airflow. In these cases, the settings should be maintained until the evaporator superheat has been checked and adjusted.

The default pressure fan cycling settings are optimized to maintain a minimum 65°F condensing temperature for medium temperature applications, and 45°F condensing temperature for low temperature applications.

Systems with Head Pressure Valves (ORI/ORD)

For these systems the general recommendation is to use a clear sight glass as an indication of proper refrigerant charge, then add an additional amount for condenser flooding (See Table on Pages 52-53). During cooler ambient temperatures the fan cycle settings should be temporarily changed to yield a 105°F minimum condensing temperature during the charging process. An alternate method is to temporarily block a portion of the entering air condenser surface to restrict airflow. In these cases, the settings should be maintained until the evaporator superheat has been checked and adjusted.

The default pressure fan cycling settings should be appropriate for 150psi discharge pressure setting on the ORI valve for medium temperature applications and 100psi discharge pressure setting on the ORI valve for low temperature applications.

Systems with Floating (Low) Head Pressure

For these systems the general recommendation is to use a clear sight glass as an indication of proper refrigerant charge. During cooler ambient temperatures the fan cycle settings should be temporarily changed to yield a 105°F minimum condensing temperature during the charging process. An alternate method is to temporarily block a portion of the entering air condenser surface to restrict airflow. In these cases, the settings should be maintained until the evaporator superheat has been checked and adjusted.

There are a number of different fan cycling possibilities for floating head systems. Generally, fans are turned off with decreasing ambient temperature to save energy. The first (header) fan is run continuously with the compressor and other fans are controlled by pressure or ambient temperature.

Please note that special expansion valve and nozzle selections are often required for floating head pressure applications.

Operational Check Out

Operational Check Out

After the system has been charged and has operated for at least two hours at normal operating conditions without any indication of malfunction, it should be allowed to operate overnight on automatic controls. Then a thorough recheck of the entire system operation should be made as follows:

- (a) Check compressor discharge and suction pressures.
If not within system design limits, determine why and take corrective action.
- (b) Check liquid line sight glass and expansion valve operation. If there are indications that more refrigerant is required, leak test all connections and system components and repair any leaks before adding refrigerant.
- (c) Observe oil level in compressor crankcase sight glass. Add oil as necessary to bring level to bottom 1/4 of the sight glass.
- (d) Thermostatic expansion valves must be checked for proper superheat settings. Valves set at high superheat will lower refrigeration capacity. Low superheat promotes liquid slugging and compressor bearing washout.
- (e) Using suitable instruments, carefully check line voltage and amperage at the compressor terminals. Voltage must be within 10% of that indicated on the condensing unit nameplate. If high or low voltage is indicated, notify the power company. If amperage draw is excessive, immediately determine the cause and take corrective action. On three phase motor compressors, check to see that a balanced load is drawn by each phase.
- (f) The maximum approved settings for high pressure controls on our air cooled condensing equipment is 425 psig. On air cooled systems, check as follows: Disconnect the fan motors or block the condenser inlet air. Watch high pressure gauge for cutout point. Recheck all safety and operating controls for proper operation and adjust if necessary.
- (g) Once the room is near design temperature, observe a defrost cycle. The defrost sequence may be manually started by pressing the force defrost button
- (h) Check drain pan for proper drainage.
- (i) Check head pressure controls for pressure setting.
- (j) Check crankcase heater operation.
- (k) Install instruction card and control system diagram for use of building manager or owner.

IMPORTANT: In order to obtain the maximum capacity from a system, and to ensure trouble-free operation, it is necessary to balance each and every system.

This is extremely important with any refrigeration system.

The critical value which must be checked is suction superheat.

Suction superheat should be checked **at the compressor** as follows:

1. Measure the suction pressure at the suction service valve of the compressor and determine the saturation temperature corresponding to this pressure from a "Temperature-Pressure" chart.
2. Measure the suction temperature of the suction line about one foot back from the compressor using an accurate thermometer.
3. Subtract the saturated temperature from the actual suction line temperature. The difference is superheat.

Too low a suction superheat can result in liquid being returned to the compressor. This will cause dilution of the oil and eventual failure of the bearings and rings or in the extreme case, valve failure.

Too high a suction superheat will result in excessive discharge temperatures which cause a break down of the oil and results in piston ring wear, piston and cylinder wall damage.

It should also be remembered that the system capacity decreases as the suction superheat increases. For maximum system capacity, suction superheat should be kept as low as is practical. Copeland mandates a **minimum** superheat of 20°F **at the compressor**. We recommend that the superheat **at the compressor** be between 20°F and 30°F.

If adjustments to the suction superheat need to be made, the expansion valve at the evaporator should be adjusted.

Evaporator Superheat

Check Your Superheat. After the box temperature has reached or is close to reaching the desired temperature, the evaporator superheat should be checked and adjustments made if necessary. Generally, systems with a design TD of 10°F should have a superheat value of 6' to 10°F for maximum efficiency. For systems operating at higher TD's, the superheat can be adjusted to 12' to 15' °F as required.

NOTE: *Minimum compressor suction superheat of 20°F may override these recommendations on some systems with short line runs.*

To properly determine the superheat of the evaporator, the following procedure is the method Heatcraft recommends:

1. Measure the temperature of the suction line at the point the bulb is clamped.
2. Obtain the suction pressure that exists in the suction line at the bulb location using a gauge in the external equalized line will gauge directly in the suction line near the evaporator or directly in the suction header of the evaporator.
3. Convert the pressure obtained above to saturated evaporator temperature by using a temperature-pressure chart.
4. Subtract the saturated temperature from the actual suction line temperature. The difference is superheat.
5. For refrigerants with glide use dew point saturation values.

Refrigeration Oils

Polyol Ester Lubricants

Hygroscopicity

Ester lubricants (POE) have the characteristic of quickly absorbing moisture from the ambient surroundings. This is shown graphically in Figure 7 where it can be seen that such lubricants absorb moisture faster and in greater quantity than conventional mineral oils. Since moisture levels greater than 100 ppm will result in system corrosion and ultimate failure, it is imperative that compressors, components, containers and the entire system be kept sealed as much as possible. Lubricants will be packaged in specially designed, sealed containers. After opening, all the lubricant in a container should be used at once since it will readily absorb moisture if left exposed to the ambient. Any unused lubricant should be properly disposed of. Similarly, work on systems and compressors must be carried out with the open time as short as possible. Leaving the system or compressor open during breaks or overnight **MUST BE AVOIDED!**

Polyol Ester Lubricants

The Mobil EAL ARCTIC 22 CC is the preferred Polyol ester due to unique additives included in this lubricant. ICI Emkarate RL 32S is an acceptable Polyol ester lubricant approved for use when Mobil is not available. These POE's **must** be used if HFC refrigerants are used in the system. They are also acceptable for use with any of the traditional refrigerants or interim blends and are compatible with mineral oils. They can therefore be mixed with mineral oils when used in systems with CFC or HCFC refrigerants. These lubricants are compatible with one another and can be mixed.

Table 7. Refrigeration Oils

Traditional Refrigerants and Refrigeration Oils		HFC's R-404A, R-507, R-407A, R-407C, R-407F HFO Blends R-448A, R-449A
POE's	Mobil EAL ARCTIC 22 CC	P
	ICI (Virginia KMP) EMKARATE RL 32CF	P

P = Preferred Lubricant Choice A = Acceptable Alternative
*(Reprinted by permission from Copeland Corporation)

Color

As received, the POE lubricant will be clear or straw colored. After use, it may acquire a darker color. This does not indicate a problem as the darker color merely reflects the activity of the lubricant's protective additive.

Oil Level

During Copeland's testing of Polyol ester oil, it was found that this lubricant exhibits a greater tendency to introduce oil into the cylinder during flooded start conditions. If allowed to continue, this condition will cause mechanical failure of the compressor.

A crankcase heater is required with condensing units and it must be turned on several hours before start-up.

Oil level should not exceed 1/2 sight glass during operation.

Figure 7.

Hygroscopicity 68 F, 50% Relative Humidity

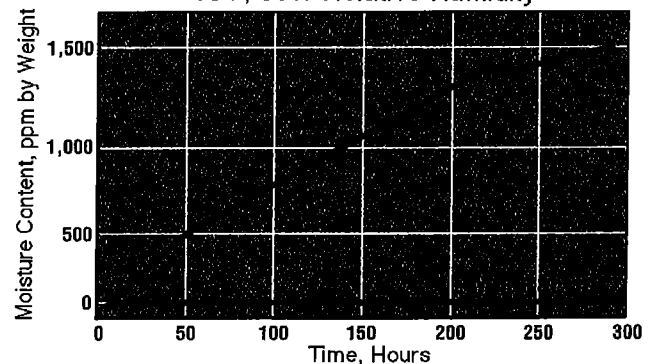

Troubleshooting

Hot Gas Controller Troubleshooting Chart

Problem	Step	Action Item	If OK	If Not OK
Input Power LED on Controller Board is not lit	1	Check Primary Power Supply Disconnected		Check fuses and/or circuit breakers
	2	Check Voltage to 24V Transformers in Condensing Unit Electrical Box	Go to next step	Re-set circuit breaker(s) on transformers
	3	Check Transformer Secondary Output Volts	Go to next step	Replace transformers if necessary, if voltage is low, check tap position on primary
	4	Check Voltage to Controller Board		Check factory wiring and connections
	5	Replace Board		
Controller Board has Input Power, Display is Blank	1	Verify that Black Jumper is Installed on "Pic Pwr" Pins to the Right of the Backup Battery Power Supply	Go to next step	Install Jumper if Missing
	1	Replace Battery on Controller Board	Go to next step	
Board Loses Time of Day Settings when Power Interrupted	1	Check that the Sensor Connections are Secure at Board. Check Field Wiring if Evap Defrost Temp Sensor		Secure, Correct the Wiring if Loose, Incorrect or Shorted
	2	Ohm the Sensor to Detect Open or Short Condition	Go to next step	Replace Sensor if Open or Shorted
	3	Check the Sensor Positions for Correct Placement	Go to next step	Place Sensor in Correct Position++
	4	Compare Displayed Value (Use Monitor Function) to Thermometer at Sensor Location		Replace Sensor if Readings do not agree
	5	Compare Displayed Value (Use Monitor Function) to Reference Temp on Ohm Table++		Replace Board if Readings do not agree
	6	Check that the Sensor Connections are Secure at Board and at the Sensor		Secure, Correct the Wiring if Loose, Incorrect or Shorted
Err4, Err5 (with or without Air1) Displaying on Controller Sensor Open or Shorted-and-Pressure Sensor General Troubleshooting	1	Ohm the Sensor to Detect Open or Short Condition	Go to next step	Replace Sensor if Damaged
	2	Check Controller Board for Shorted Components if Sensor was Shorted		Change Refrigerant Type Selected to Actual Refrigerant Used
	3	Check Refrigerant Type in Program Menu		Place Sensor in Correct Position (see Piping Diagram in Manual)
	4	Check the Sensor Positions for Correct Placement		Replace Sensor if Readings do not agree
	5	Compare Displayed Value (Use Monitor Function) to Gauge at Sensor Location		Follow General System Troubleshooting Chart, LPS Function is on the Control Board
	6	Check Service/Make Status and Service/Make Reference Guide		Replace contact(s) or Auxiliary Switch(es)
Err3 (with or without Air3) (Safety Circuit Opening)	1	Check Compressor Contactors and Auxiliary Switch(es) for Proper Operation	Go to next step	Replace Relay 1 or Correct Wiring
	2	Check Relay 1 for Proper Wiring and Operation		Follow General System Troubleshooting Chart for Low Suction Pressure
	3	View Displayed Value (Use Monitor Function) for the Suction Pressure Sensor	Go to next step	Go to Pressure Sensor Troubleshooting
Err10 (Prolonged Low Suction Pressure)	1	Compare Displayed Value (Use Monitor Function) to Gauge at Suction Pressure Sensor Location	Go to next step	Follow General System Troubleshooting Chart for Low Suction Pressure
	2	View Displayed Value (Use Monitor Function) for the Suction Pressure Sensor	Go to next step	Go to Pressure Sensor Troubleshooting
	3	Compare Displayed Value (Use Monitor Function) to Gauge at Suction Pressure Sensor Location	Go to next step	Replace valve or correct wiring
Err11 (Low Suction Pressure at Startup) (with or without Air4)	1	Check the Liquid Solenoid Valve for Proper Wiring and Operation	Go to next step	Follow General System Troubleshooting Chart for High Suction Pressure
	2	View Displayed Value (Use Monitor Function) for the Suction Pressure Sensor	Go to next step	Go to Pressure Sensor Troubleshooting
	3	Compare Displayed Value (Use Monitor Function) to Gauge at Suction Pressure Sensor Location	Go to next step	Replace valve or correct wiring
Err12 (High Suction Pressure at Startup) (with or without Air4)	1	Check Bypass Valve for Proper Wiring and Operation	Go to next step	Replace valve or correct wiring
	2	Check Defrost Valve for Proper Wiring and Operation	Go to next step	Replace valve or correct wiring
	3	Check the Liquid Solenoid Valve for Proper Wiring and Operation	Go to next step	Replace valve or correct wiring
Err13 (Post Defrost Pumpdown Error)	1	Check compressor for problems (valve or running gear issues)	Go to next step	Replace or repair compressor
	2	Check Bypass Valve for Proper Wiring and Operation	Go to next step	Replace valve or correct wiring
	3	Check the Liquid Solenoid Valve for Proper Wiring and Operation	Go to next step	Replace valve or correct wiring
	4	Check compressor for problems (valve or running gear issues)	Go to next step	Replace or repair compressor

+ Temperature Sensor Positions:
Ambient Sensor is Secured on the Condenser Side Panel to Measure Air Temperature Entering #1 Condenser Coil
Suction and Defrost Temperature Sensors are Secured in Copper Sensor Well on the Side of the Suction Line
++ Temperature Sensor Ohm Range

TEMP °F	OHMS	TEMP °F	OHMS
104	5320	32	32850
86	8060	22	42330
77	10000	14	55330
68	12480	5	72950
59	15710	-4	97070
50	19900	-13	130410
41	25400	-22	176960

Troubleshooting

General Evaporator Troubleshooting Chart

SYMPTOMS	POSSIBLE CAUSES	POSSIBLE CORRECTIVE STEPS
Fan(s) will not operate	<ol style="list-style-type: none"> 1. Main switch open 2. Blown fuses 3. Defective motor 4. Defective timer or defrost thermostat 5. Unit in defrost cycle 	<ol style="list-style-type: none"> 1. Close switch 2. Replace fuses. Check for short circuits or overload conditions 3. Replace motor 4. Replace defective component 5. Wait for completion of cycle
Room temperature too high	<ol style="list-style-type: none"> 1. Room thermostat set too high 2. Superheat too high 3. System low on refrigerant 4. Coil iced-up 5. Unit cooler located too close to doors 6. Heavy air infiltration 	<ol style="list-style-type: none"> 1. Adjust thermostat 2. Adjust thermal expansion valve 3. Add refrigerant 4. Manually defrost coil. Check defrost controls for malfunction 5. Relocate unit cooler or add strip curtain to door opening 6. Seal unwanted openings in room
Ice accumulating on ceiling around evaporator and/or on fan guards venturi or blades	<ol style="list-style-type: none"> 1. Defrost duration is too long 2. Defective defrost thermostat or timer 3. Too many defrosts 	<ol style="list-style-type: none"> 1. Adjust defrost termination settings 2. Replace defective component 3. Reduce number of defrosts
Coil not clearing of frost during defrost cycle	<ol style="list-style-type: none"> 1. Coil temperature not getting above freezing point during defrost 2. Not enough defrost cycles per day 3. Defrost cycle too short 4. Defective timer or defrost thermostat 	<ol style="list-style-type: none"> 1. Check heater operation 2. Adjust controller for more defrost cycles 3. Adjust defrost settings for longer cycle 4. Replace defective component
Ice accumulating in drain pan	<ol style="list-style-type: none"> 1. Defective heater 2. Unit not pitched properly 3. Drain line plugged 4. Defective drain line heater 5. Defective timer or thermostat 	<ol style="list-style-type: none"> 1. Replace heater 2. Check and adjust if necessary 3. Clean drain line 4. Replace heater 5. Replace defective component
Uneven coil frosting	<ol style="list-style-type: none"> 1. Located too close to door or opening 2. Defrost termination set too low 3. Incorrect or missing distributor nozzle 	<ol style="list-style-type: none"> 1. Relocate evaporator 2. Adjust defrost termination setting higher. 3. Add or replace nozzle with appropriately sized orifice for conditions.

Troubleshooting

General System Troubleshooting Chart

PROBLEM	POSSIBLE CAUSES	POSSIBLE CORRECTIVE STEPS
Compressor will not run	<ol style="list-style-type: none"> 1. Main switch open. 2. Fuse blown. 3. Thermal overloads tripped. 4. Defective contactor or coil. 5. System shut down by safety devices. 6. No cooling required. 7. Liquid line solenoid will not open. 8. Motor electrical trouble. 9. Loose wiring. 10. Phase loss monitor inoperative. 	<ol style="list-style-type: none"> 1. Close switch. 2. Check electrical circuits and motor winding for shorts or grounds Investigate for possible overloading. Replace fuse after fault is corrected. 3. Overloads are automatically reset. Check unit closely when unit comes back on line. 4. Repair or replace. 5. Determine type and cause of shutdown and correct it before resetting safety switch. 6. None. Wait until calls for cooling. 7. Repair or replace coil. 8. Check motor for open windings, short circuit or burn out. 9. Check all wire junctions. Tighten all terminal screws. 10. Refer to page 24.
Compressor noisy or vibrating	<ol style="list-style-type: none"> 1. Flooding of refrigerant into crankcase. 2. Improper piping support on suction or liquid line. 3. Worn compressor. 	<ol style="list-style-type: none"> 1. Check setting of expansion valves. 2. Relocate, add or remove hangers. 3. Replace.
High discharge pressure	<ol style="list-style-type: none"> 1. Non-condensables in system. 2. System overcharges with refrigerant. 3. Discharge shutoff valve partially closed. 4. Fan not running. 5. Head pressure control setting. 6. Dirty condenser coil. 	<ol style="list-style-type: none"> 1. Remove the non-condensables. 2. Remove excess. 3. Open valve. 4. Check electrical circuit. 5. Adjust. 6. Clean.
Low discharge pressure	<ol style="list-style-type: none"> 1. Faulty condenser temperature regulation. 2. Suction shutoff valve partially closed. 3. Insufficient refrigerant in system. 4. Low suction pressure. 5. Variable head pressure valve. 	<ol style="list-style-type: none"> 1. Check condenser control operation. 2. Open valve. 3. Check for leaks. Repair and add charge. 4. See corrective steps for low suction pressure. 5. Check valve setting.
High suction pressure	<ol style="list-style-type: none"> 1. Excessive load. 2. Expansion valve overfeeding. 	<ol style="list-style-type: none"> 1. Reduce load or add additional equipment. 2. Check remote bulb. Regulate superheat.
Low suction pressure	<ol style="list-style-type: none"> 1. Lack of refrigerant. 2. Evaporator dirty or iced. 3. Clogged liquid line filter drier. 4. Clogged suction line or compressor suction gas strainers. 5. Expansion valve malfunctioning. 6. Condensing temperature too low. 7. Improper TXV. 	<ol style="list-style-type: none"> 1. Check for leaks. Repair and add charge. 2. Clean. 3. Replace cartridge(s). 4. Clean strainers. 5. Check and reset for proper superheat. 6. Check means for regulating condensing temperature. 7. Check for proper sizing.
Little or no oil pressure	<ol style="list-style-type: none"> 1. Clogged suction oil strainer. 2. Excessive liquid in crankcase. 3. Low oil pressure safety switch defective. 4. Worn oil pump. 5. Oil pump reversing gear stuck in wrong position. 6. Worn bearings. 7. Low oil level. 8. Loose fitting on oil lines. 9. Pump housing gasket leaks. 	<ol style="list-style-type: none"> 1. Clean. 2. Check crankcase heater. Reset expansion valve for higher superheat. Check liquid line solenoid valve operation. 3. Replace. 4. Replace. 5. Reverse direction of compressor rotation. 6. Replace compressor. 7. Add oil and/or through defrost. 8. Check and tighten system. 9. Replace gasket.
Compressor loses oil	<ol style="list-style-type: none"> 1. Lack of refrigerant. 2. Excessive compression ring blow by. 3. Refrigerant flood back. 4. Improper piping or traps. 	<ol style="list-style-type: none"> 1. Check for leaks and repair. Add refrigerant. 2. Replace compressor. 3. Maintain proper superheat at compressor. 4. Correct piping.
Compressor thermal protector switch open	<ol style="list-style-type: none"> 1. Operating beyond design conditions. 2. Discharge valve partially shut. 3. Blown valve plate gasket. 4. Dirty condenser coil. 5. Overcharged system. 	<ol style="list-style-type: none"> 1. Add components to bring conditions within acceptable limits (Consult Heatcraft) 2. Open valve. 3. Replace gasket. 4. Clean coil. 5. Reduce charge.

Preventive Maintenance

Unit Coolers

At every six month interval, or sooner if local conditions cause clogging or fouling of air passages through the finned surface, the following items should be checked.

- 1) Visually inspect unit
 - Look for signs of corrosion on fins, cabinet, copper tubing and solder joints.
 - Look for excessive or unusual vibration for fan blades or sheet metal panels when in operation. Identify fan cell(s) causing vibration and check motor and blade carefully.
 - Look for oil stains on headers, return bends, and coil fins. Check any suspect areas with an electronic leak detector.
 - Check drain pan to insure that drain is clear of debris, obstructions or ice buildup and is free draining.
- 2) Clean evaporator coil and blades
 - Periodic cleaning can be accomplished by using a brush, pressurized water or a commercially available evaporator coil cleaner or mild detergent. Never use an acid based cleaner. Follow label directions for appropriate use. Be sure the product you use is approved for use in your particular application.
 - Flush and rinse coil until no residue remains.
 - Pay close attention to drain pan, drain line and trap.
- 3) Check the operation of all fans and ensure airflow is unobstructed
 - Check that each fan rotates freely and quietly. Replace any fan motor that does not rotate smoothly or makes an unusual noise.
 - Check all fan set screws and tighten if needed.
 - Check all fan blades for signs of stress or wear. Replace any blades that are worn, cracked or bent.
 - Verify that all fan motors are securely fastened to the motor rail.
 - Lubricate motors if applicable.
- 4) Inspect electrical wiring and components
 - Visually inspect all wiring for wear, kinks, bare areas and discoloration. Replace any wiring found to be damaged.
 - Verify that all electrical and ground connections are secure, tighten if necessary.
 - Check operation/calibration of all fan cycle and defrost controls when used.
 - Look for abnormal accumulation of ice patterns and adjust defrost cycles accordingly
 - Compare actual defrost heater amp draw against unit data plate.
 - Check drain line heat tape for proper operation (supplied and installed by others).
- 5) Refrigeration Cycle
 - Check unit cooler superheat and compare reading for your specific application
 - Visually inspect coil for even distribution

Air Cooled Condensing Units

Quarterly

- 1) Visually inspect unit
 - Look for signs of oil stains on interconnection piping and condenser coil. Pay close attention to areas around solder joints, building penetrations and pipe clamps. Check any suspect areas with an electronic leak detector. Repair any leaks found and add refrigerant as needed.
 - Check condition of moisture indicator/sightglass in the sight glass if so equipped. Replace liquid line drier if there is indication of slight presence of moisture. Replace refrigerant, oil and drier if moisture concentration is indicated to be high.
 - Check moisture indicator/sightglass for flash gas. If found check entire system for refrigerant leaks and add refrigerant as needed after repairing any leaks.
 - Check compressor sightglass (if equipped) for proper oil level.
 - Check condition of condenser. Look for accumulation of dirt and debris (clean as required).
 - Check for unusual noise or vibration. Take corrective action as required.
 - Inspect wiring for signs of wear or discoloration and repair if needed.
 - Check and tighten all flare connections.

Semi-Annually

- 2) Repeat all quarterly inspection items.
- 3) Clean condenser coil and blades
 - Periodic cleaning can be accomplished by using a brush, pressurized water and a commercially available foam coil cleaner. If foam cleaner is used, it should not be an acid based cleaner. Follow label directions for appropriate use.
 - Rinse until no residue remains.
- 4) Check operation of condenser fans
 - Check that each fan rotates freely and quietly. Replace any fan motor that does not rotate smoothly or makes excessive noise.
 - Check all fan blade set screws and tighten as required.
 - Check all fan blades for signs of cracks, wear or stress. Pay close attention to the hub and spider. Replace blades as required.
 - Verify that all motors are mounted securely.
 - Lubricate motors if applicable. Do not lubricate permanently sealed, ball bearing motors.

Preventive Maintenance

Semi-Annually (cont.)

- 5) Inspect electrical wiring and components
 - Verify that all electrical and ground connections are secure, tighten as required.
 - Check condition of compressor and heater contactors. Look for discoloration and pitting. Replace as required.
 - Check operation and calibration of all timers, relays pressure controls and safety controls.
 - Clean electrical cabinet. Look for signs of moisture, dirt, debris, insects and wildlife. Take corrective action as required.
 - Verify operation of crankcase heater by measuring amp draw.
- 6) Check refrigeration cycle
 - Check suction, discharge and net oil pressure readings. If abnormal take appropriate action.
 - Check pressure drop across all filters and driers. Replace as required.
 - Verify that superheat at the compressor conforms to specification. (See page 54)
 - Check pressure and safety control settings and verify proper operation.

Annually

- 7) In addition to quarterly and semiannual maintenance checks, submit an oil sample for analysis
 - Look for high concentrations of acid or moisture. Change oil and driers until test results read normal.
 - Investigate source of high metal concentrations, which normally are due to abnormal bearing wear. Look for liquid refrigerant in the crankcase, low oil pressure or low superheat as a possible source.
- 8) Inspect suction accumulator (if equipped)
 - If the accumulator is insulated remove insulation and inspect for leaks and corrosion.
 - Pay close attention to all copper to steel brazed connections
 - Wire brush all corroded areas and peeling paint.
 - Apply an anticorrosion primer and paint as required. Re-insulate if applicable.
 - Check accuracy of the suction line temperature and pressure sensors before the suction accumulator by comparing the controller reading in the monitor mode to a thermometer and pressure gauge of known accuracy

InterLink Service Parts

Hot Gas Defrost System Service Parts

Whenever possible, replacement parts are to be obtained from a local wholesaler authorized to sell one of Heatcraft Refrigeration Products' brands. Replacement parts which are covered under the terms of the warranty statement on page 6 of this manual, will be reimbursed for total part cost only. The original invoice from the parts supplier must accompany all warranty claims for replacement part reimbursement. Heatcraft Refrigeration Products reserves the right to adjust the compensation amount paid on any parts submitted for warranty reimbursement when a parts supplier's original invoice is not provided with a claim. You may obtain information regarding local authorized wholesalers by calling the InterLink Service Parts Center at 1-800-686-7278 between the hours of 7:30 AM to 4:30 PM Central Time.

ELECTRICAL PARTS	
Description	Part Number
Hot Gas Control Board	28910302
Transformer 100VA 24V - 208/230V	22555601
Electronic Pressure Regulator ⁺	29326701
Pressure Regulator Harness ⁺	22592201
Suction Pressure Transducer (0-300 PSIA)	28911202
Suction Transducer Harness (Blue)	22515102
Liquid Pressure Transducer (0-500 PSIA)	28911203
Liquid Transducer Harness (Black)	22515103
Suction Temp Sensor (Blue)	28900310
Ambient /Room Temp Sensor (White 93" leads)	28900311
High Pressure Switch	28913201
Evaporator Sensor	28900108
Evaporator Contactor 30A	2252430
Evaporator Contactor 40A	2252440
Evap Liquid Solenoid 1/2" conn	29324201
Evap Liquid Solenoid 5/8" conn	29324301
Evap Liquid Solenoid 7/8" conn	29324401
Low Pressure Switch (Redundant)	2890099
Coil (Parker SC) 24V	22593201

LEGACY CONDENSING UNIT PIPING COMPONENTS					
Legacy Condensing Unit Model	3-Way Valve	Suction Stop Solenoid Valve	Defrost Solenoid Valve	Bypass Solenoid Valve	Aeroquip Hose
0602L6	29323601	29330301	29321701	29324201	28991004
0752L6	29323601	29330301	29321701	29324201	28991004
0902L6	29323701	29330401	29321801	29324201	28991002
01002L6	29323701	29330401	29321801	29324201	28991002
01202L6	29323701	29330401	29321901	29324201	28991002
01502L6	29323701	29330402	29321901	29324301	28991002
2202L6	29323701	29330402	29330402	29324301	28991001
2702L6	29323801	29330403	29330402	29324301	28991009
3002L6	29323801	29330403	29330402	29324301	28991009
0752 M6	29323701	29330301	29321701	29324201	28991003
0762 M6	29323701	29330301	29321701	29324201	28991003
0802 M6	29323701	29330401	29321801	29324201	28991002
1002 M6	29323701	29330401	29321801	29324201	28991002
1202 M6	29323701	29330402	29321901	29324301	28991002
1502 M6	29323801	29330402	29321901	29324301	28991009
2002 M6	29323801	29330402	29321901	29324301	28991002
2502 M6	29323801	29330403	29330402	29324401	28991001
3002 M6	29323801	29330403	29330402	29324401	28991001
3502 M6	29323801	29330402 (2)	29330403	29324401	28991001
4002 M6	29323801	29330402 (2)	29330403	29324401	28991001
0752 M2	29323701	29330301	29321701	29324201	28991003
0762 M2	29323701	29330301	29321701	29324201	28991003
0802 M2	29323701	29330401	29321801	29324201	28991002
1002 M2	29323701	29330401	29321801	29324201	28991002
1202 M2	29323701	29330402	29321901	29324301	28991002
1502 M2	29323801	29330402	29321901	29324301	28991009
2002 M2	29323801	29330402	29321901	29324301	28991002
2502 M2	29323801	29330403	29330402	29324401	28991001
3002 M2	29323801	29330403	29330402	29324401	28991001
3502 M2	29323801	29330402 (2)	29330403	29324401	28991001
4002 M2	29323801	29330402 (2)	29330403	29324401	28991001

InterLink Service Parts

Hot Gas Defrost System Service Parts (cont.)

MEET MINIMUM AWEF CONDENSING UNIT PIPING COMPONENTS					
Meet Minimum AWEF Condensing Unit Model	3-Way Valve	Suction Stop Solenoid Valve	Defrost Solenoid Valve	Bypass Solenoid Valve	Aeroquip Hose
0062L	29323701	29330402	29330402	29324301	28991001
0077L	29323701	29330402	29330402	29324301	28991001
0092L	29323701	29330402	29330402	29324301	28991001
0102L	29323701	29330402	29330402	29324301	28991001
0122L	29323701	29330402	29330402	29324301	28991001
0152L	29323701	29330402	29330402	29324301	28991001
0222L	29323701	29330402	29330402	29324301	28991001
0272L	29323801	29330403	29330402	29324301	28991009
0302L	29323801	29330403	29330402	29324301	28991009
0077M	29323801	29330402	29321901	29324301	28991009
0078M	29323801	29330402	29321901	29324301	28991009
0082M	29323801	29330402	29321901	29324301	28991009
0102M	29323801	29330402	29321901	29324301	28991009
0122M	29323801	29330402	29321901	29324301	28991009
0152M	29323801	29330402	29321901	29324301	28991009
0202M	29323801	29330402	29321901	29324301	28991002
0252M	29323801	29330403	29330402	29324401	28991001
0302M	29323801	29330403	29330402	29324401	28991001
0352M	29323801	29330402 (2)	29330403	29324401	28991001
0402M	29323801	29330402 (2)	29330403	29324401	28991001

*Effective 2/15/12, production and service parts will use the 28910302 control board with V1.06 software which is backwards compatible with all previous versions. See Pages 65 for installation and wiring differences.
 + Effective 11/1/11, production and service parts will use the 29326701 Carel pressure regulator and 22592201 harness. See Page 66 for valve identification and Page 63-64 for regulator program settings. V1.06 software is programmed for the Carel valve. Also may be selected in Expert mode or the parameters may be programmed manually on the previous 28910301 control board.

NOTE: for suction stop and defrost valves use the following valve seal kits:

Valve: HRP # 29330301 use Parker #204671

Valve: HRP# 29330401,02,03 use Parker #204670

Service Record

A permanent data sheet should be prepared on each refrigeration system at an installation, with a copy for the owner and the original for the installing contractor's files.

If another firm is to handle service and maintenance, additional copies should be prepared as necessary.

System Reference Data

The following information should be filled out and signed by Refrigeration Installation Contractor at time of start-up.

Date System Installed: _____

Installer and Address: _____

Condensing Unit

Unit Model#: _____

Unit Serial #: _____

Compressor Model #: _____ Compressor Model #: _____

Compressor Serial #: _____ Compressor Serial #: _____

Electrical _____ Volts _____ Phase _____

Voltage at Compressor L1 _____ L2 _____ L3 _____

Amperage at Compressor L1 _____ L2 _____ L3 _____

Evaporator(s)

Quantity _____

Evaporator Model #: _____ Evaporator Model #: _____

Evaporator Serial #: _____ Evaporator Serial #: _____

Electrical _____ Volts _____ Phase _____

Expansion Valve Manufacturer/Model _____

Ambient at Start-Up _____ °F

Design Box Temperature _____ °F _____ °F

Operating Box Temperature _____ °F _____ °F

Thermostat Setting _____ °F _____ °F

Defrost Setting _____ / day _____ minutes fail-safe _____ /day _____ minutes fail-safe

Compressor Discharge Pressure _____ PSIG _____ PSIG

Compressor Suction Pressure _____ PSIG _____ PSIG

Suction Line Temperature @ Comp. _____ °F _____ °F

Discharge Line Temperature @ Comp. _____ °F _____ °F

Superheat at Compressor _____ °F _____ °F

Suction Line Temperature @ Evaporator _____ °F _____ °F

Superheat at Evaporator _____ °F _____ °F

Evacuation: # times _____ Final Micron _____ # Times _____ Final Micron _____

Evaporator Drain Line Trapped Outside of Box: yes no

Factory Default Settings

Legacy Model Factory Default Settings

APPLICATION	REFRIGERANT	MODEL SIZE	Fan Cycle Settings (Liquid Pressure, PRES), psig								DFT 1								CAREL		ALCO	
			Fan 1	Fan 2	Fan 3	Fan 4	Fan 1	Fan 2	Fan 3	Fan 4	DFT 2	DEFP	DEFT	EQU	LPSH	LPSL	FZET	FZTM	PRFS	PRFS	PRUI	DFIO
			ON	ON	ON	ON	OFF	OFF	OFF	OFF	°F	psig	Min.	Min.	psig	psig	°F	Min.				
M2	R22	752, 762	155	170	---	---	110	145	---	---	85	210	25	2	16	6	35	4	320	300	15	100
M2	R22	802	155	170	---	---	110	145	---	---	85	210	25	2	16	6	35	4	320	300	15	100
M2	R22	1002	155	170	---	---	110	145	---	---	85	210	25	2	16	6	35	4	350	320	15	100
M2	R22	1202	155	170	---	---	110	145	---	---	85	210	25	2	16	6	35	4	380	340	15	100
M2	R22	1502	155	170	---	---	110	145	---	---	85	210	25	2	16	6	35	4	410	380	15	100
M2	R22	2002	155	170	---	---	110	145	---	---	85	210	25	2	16	6	35	4	470	440	15	100
M2	R22	2502	155	170	180	---	110	145	155	---	85	210	25	2	16	6	35	4	510	520	17	100
M2	R22	3002	155	170	180	---	110	145	155	---	85	210	25	2	16	6	35	4	550	600	20	100
M2	R22	3502	155	170	180	---	110	145	155	---	85	210	25	2	16	6	35	4	570	700	23	100
M2	R22	4002	155	170	180	195	110	145	155	170	85	210	25	2	16	6	35	4	590	780	25	100
M6	R404A	752, 762	190	205	---	---	135	175	---	---	85	210	25	2	24	10	35	4	320	300	15	100
M6	R404A	802	190	205	---	---	135	175	---	---	85	210	25	2	24	10	35	4	320	300	15	100
M6	R404A	1002	190	205	---	---	135	175	---	---	85	210	25	2	24	10	35	4	350	320	15	100
M6	R404A	1202	190	205	---	---	135	175	---	---	85	210	25	2	24	10	35	4	380	340	15	100
M6	R404A	1502	190	205	---	---	135	175	---	---	85	210	25	2	24	10	35	4	410	380	15	100
M6	R404A	2002	190	205	---	---	135	175	---	---	85	210	25	2	24	10	35	4	470	440	15	100
M6	R404A	2502	190	205	220	---	135	175	190	---	85	210	25	2	24	10	35	4	510	520	17	100
M6	R404A	3002	190	205	220	---	135	175	190	---	85	210	25	2	24	10	35	4	550	600	20	100
M6	R404A	3502	190	205	220	---	135	175	190	---	85	210	25	2	24	10	35	4	570	700	23	100
M6	R404A	4002	190	205	220	235	135	175	190	205	85	210	25	2	24	10	35	4	590	780	25	100
M6	R507	752, 762	195	210	---	---	140	180	---	---	85	210	25	2	26	11	35	4	320	300	15	100
M6	R507	802	195	210	---	---	140	180	---	---	85	210	25	2	26	11	35	4	320	300	15	100
M6	R507	1002	195	210	---	---	140	180	---	---	85	210	25	2	26	11	35	4	350	320	15	100
M6	R507	1202	195	210	---	---	140	180	---	---	85	210	25	2	26	11	35	4	380	340	15	100
M6	R507	1502	195	210	---	---	140	180	---	---	85	210	25	2	26	11	35	4	410	380	15	100
M6	R507	2002	195	210	---	---	140	180	---	---	85	210	25	2	26	11	35	4	470	440	15	100
M6	R507	2502	195	210	225	---	140	180	195	---	85	210	25	2	26	11	35	4	510	520	17	100
M6	R507	3002	195	210	225	---	140	180	195	---	85	210	25	2	26	11	35	4	550	600	20	100
M6	R507	3502	195	210	225	---	140	180	195	---	85	210	25	2	26	11	35	4	570	700	23	100
M6	R507	4002	195	210	225	245	140	180	195	210	85	210	25	2	26	11	35	4	590	780	25	100
M6	R407A	752, 762	190	205	---	---	135	175	---	---	85	210	25	2	15	3	35	4	320	300	15	100
M6	R407A	802	190	205	---	---	135	175	---	---	85	210	25	2	15	3	35	4	320	300	15	100
M6	R407A	1002	190	205	---	---	135	175	---	---	85	210	25	2	15	3	35	4	350	320	15	100
M6	R407A	1202	190	205	---	---	135	175	---	---	85	210	25	2	15	3	35	4	380	340	15	100
M6	R407A	1502	190	205	---	---	135	175	---	---	85	210	25	2	15	3	35	4	410	380	15	100
M6	R407A	2002	190	205	---	---	135	175	---	---	85	210	25	2	15	3	35	4	470	440	15	100
M6	R407A	2502	190	205	220	---	135	175	190	---	85	210	25	2	15	3	35	4	510	520	17	100
M6	R407A	3002	190	205	220	---	135	175	190	---	85	210	25	2	15	3	35	4	550	600	20	100
M6	R407A	3502	190	205	220	---	135	175	190	---	85	210	25	2	15	3	35	4	570	700	23	100

Factory Default Settings

Legacy Model Factory Default Settings (cont.)

APPLICATION	REFRIGERANT	MODEL SIZE	Fan Cycle Settings (Liquid Pressure, PRES), psig								DFT 1									CAREL	ALCO	
			Fan 1	Fan 2	Fan 3	Fan 4	Fan 1	Fan 2	Fan 3	Fan 4		DFT 2	DEFP	DEFT	EQU	LPSH	LPSL	FZET	FZTM			
			ON	ON	ON	ON	OFF	OFF	OFF	OFF		°F	psig	Min.	Min.	psig	psig	°F	Min.			PRFS
M6	R407A	4002	190	205	220	235	135	175	190	205	85	210	25	2	15	3	35	4	590	780	25	100
M6	R407C	752, 762	180	195	---	---	130	165	---	---	85	210	25	2	12	1	35	4	320	300	15	100
M6	R407C	802	180	195	---	---	130	165	---	---	85	210	25	2	12	1	35	4	320	300	15	100
M6	R407C	1002	180	195	---	---	130	165	---	---	85	210	25	2	12	1	35	4	350	320	15	100
M6	R407C	1202	180	195	---	---	130	165	---	---	85	210	25	2	12	1	35	4	380	340	15	100
M6	R407C	1502	180	195	---	---	130	165	---	---	85	210	25	2	12	1	35	4	410	380	15	100
M6	R407C	2002	180	195	---	---	130	165	---	---	85	210	25	2	12	1	35	4	470	440	15	100
M6	R407C	2502	180	195	210	---	130	165	180	---	85	210	25	2	12	1	35	4	510	520	17	100
M6	R407C	3002	180	195	210	---	130	165	180	---	85	210	25	2	12	1	35	4	550	600	20	100
M6	R407C	3502	180	195	210	---	130	165	180	---	85	210	25	2	12	1	35	4	570	700	23	100
M6	R407C	4002	180	195	210	225	130	165	180	195	85	210	25	2	12	1	35	4	590	780	25	100
M6	R407F	752, 762	200	215	---	---	145	185	---	---	85	215	25	2	16	4	35	4	320	300	15	100
M6	R407F	802	200	215	---	---	145	185	---	---	85	215	25	2	16	4	35	4	320	300	15	100
M6	R407F	1002	200	215	---	---	145	185	---	---	85	215	25	2	16	4	35	4	350	320	15	100
M6	R407F	1202	200	215	---	---	145	185	---	---	85	215	25	2	16	4	35	4	380	340	15	100
M6	R407F	1502	200	215	---	---	145	185	---	---	85	215	25	2	16	4	35	4	410	380	15	100
M6	R407F	2002	200	215	---	---	145	185	---	---	85	215	25	2	16	4	35	4	470	440	15	100
M6	R407F	2502	200	215	230	---	145	185	200	---	85	215	25	2	16	4	35	4	510	520	17	100
M6	R407F	3002	200	215	230	---	145	185	200	---	85	215	25	2	16	4	35	4	550	600	20	100
M6	R407F	3502	200	215	230	---	145	185	200	---	85	215	25	2	16	4	35	4	570	700	23	100
M6	R407F	4002	200	215	230	250	145	185	200	215	85	215	25	2	16	4	35	4	590	780	25	100
L6	R404A	602	190	205	---	---	135	175	---	---	75	180	25	2	10	2	30	4	320	300	15	100
L6	R404A	752	190	205	---	---	135	175	---	---	75	180	25	2	10	2	30	4	350	320	15	100
L6	R404A	902	190	205	---	---	135	175	---	---	75	180	25	2	10	2	30	4	400	360	15	100
L6	R404A	1002	190	205	---	---	135	175	---	---	75	180	25	2	10	2	30	4	410	380	15	100
L6	R404A	1202	190	205	---	---	135	175	---	---	75	180	25	2	10	2	30	4	450	420	15	100
L6	R404A	1502	190	205	---	---	135	175	---	---	75	180	25	2	10	2	30	4	480	460	16	100
L6	R404A	2202	190	205	---	---	135	175	---	---	75	180	25	2	10	2	30	4	540	580	19	100
L6	R404A	2702	190	205	---	---	135	175	---	---	75	180	25	2	10	2	30	4	560	660	22	100
L6	R404A	3002	190	205	---	---	135	175	---	---	75	180	25	2	10	2	30	4	580	720	23	100
L6	R507	602	195	210	---	---	140	180	---	---	75	180	25	2	11	2	30	4	320	300	15	100
L6	R507	752	195	210	---	---	140	180	---	---	75	180	25	2	11	2	30	4	350	320	15	100
L6	R507	902	195	210	---	---	140	180	---	---	75	180	25	2	11	2	30	4	400	360	15	100
L6	R507	1002	195	210	---	---	140	180	---	---	75	180	25	2	11	2	30	4	410	380	15	100
L6	R507	1202	195	210	---	---	140	180	---	---	75	180	25	2	11	2	30	4	450	420	15	100
L6	R507	1502	195	210	---	---	140	180	---	---	75	180	25	2	11	2	30	4	480	460	16	100
L6	R507	2202	195	210	---	---	140	180	---	---	75	180	25	2	11	2	30	4	540	580	19	100
L6	R507	2703	195	210	---	---	140	180	---	---	75	180	25	2	11	2	30	4	560	660	22	100
L6	R507	3002	195	210	---	---	140	180	---	---	75	180	25	2	11	2	30	4	580	720	23	100

Factory Default Settings

Legacy Model Factory Default Settings (cont.)

APPLICATION	REFRIGERANT	MODEL SIZE	Fan Cycle Settings (Liquid Pressure, PRES), psig								DFT 1								CAREL	ALCO		
			Fan 1	Fan 2	Fan 3	Fan 4	Fan 1	Fan 2	Fan 3	Fan 4	DFT 2	DEFP	DEFT	EQU	LPSH	LPSL	FZET	FZTM				
			ON	ON	ON	ON	OFF	OFF	OFF	OFF	°F	psig	Min.	Min.	psig	psig	°F	Min.	PRFS	PRFS	PRUI	DFIO
M6	R448A	752, 762	195	210	---	---	140	180	---	---	85	215	25	2	26	10	35	4	320	300	15	100
M6	R448A	802	195	210	---	---	140	180	---	---	85	215	25	2	26	10	35	4	320	300	15	100
M6	R448A	1002	195	210	---	---	140	180	---	---	85	215	25	2	26	10	35	4	320	300	15	100
M6	R448A	1202	195	210	---	---	140	180	---	---	85	215	25	2	26	10	35	4	350	320	15	100
M6	R448A	1502	195	210	---	---	140	180	---	---	85	215	25	2	26	10	35	4	380	340	15	100
M6	R448A	2002	195	210	---	---	140	180	---	---	85	215	25	2	26	10	35	4	410	380	15	100
M6	R448A	2502	195	210	225	---	140	180	195	---	85	215	25	2	26	10	35	4	470	440	17	100
M6	R448A	3002	195	210	225	---	140	180	195	---	85	215	25	2	26	10	35	4	510	520	20	100
M6	R448A	3502	195	210	225	---	140	180	195	---	85	215	25	2	26	10	35	4	550	600	23	100
M6	R448A	4002	195	210	225	240	140	180	195	210	85	215	25	2	26	10	35	4	570	700	25	100
M6	R449A	752, 762	195	210	---	---	140	180	---	---	85	215	25	2	26	10	35	4	590	780	15	100
M6	R449A	802	195	210	---	---	140	180	---	---	85	215	25	2	26	10	35	4	320	300	15	100
M6	R449A	1002	195	210	---	---	140	180	---	---	85	215	25	2	26	10	35	4	320	300	15	100
M6	R449A	1202	195	210	---	---	140	180	---	---	85	215	25	2	26	10	35	4	350	320	15	100
M6	R449A	1502	195	210	---	---	140	180	---	---	85	215	25	2	26	10	35	4	380	340	15	100
M6	R449A	2002	195	210	---	---	140	180	---	---	85	215	25	2	26	10	35	4	410	380	15	100
M6	R449A	2502	195	210	225	---	140	180	195	---	85	215	25	2	26	10	35	4	470	440	17	100
M6	R449A	3002	195	210	225	---	140	180	195	---	85	215	25	2	26	10	35	4	510	520	20	100
M6	R449A	3502	195	210	225	---	140	180	195	---	85	215	25	2	26	10	35	4	550	600	23	100
M6	R449A	4002	195	210	225	240	140	180	195	210	85	215	25	2	26	10	35	4	570	700	25	100
L6	R448A	602	195	210	---	---	140	180	---	---	75	215	25	2	26	2	30	4	590	780	15	100
L6	R448A	752	195	210	---	---	140	180	---	---	75	215	25	2	10	2	30	4	320	300	15	100
L6	R448A	902	195	210	---	---	140	180	---	---	75	215	25	2	10	2	30	4	350	320	15	100
L6	R448A	1002	195	210	---	---	140	180	---	---	75	215	25	2	10	2	30	4	400	360	15	100
L6	R448A	1202	195	210	---	---	140	180	---	---	75	215	25	2	10	2	30	4	410	380	15	100
L6	R448A	1502	195	210	---	---	140	180	---	---	75	215	25	2	10	2	30	4	450	420	16	100
L6	R448A	2202	195	210	---	---	140	180	---	---	75	215	25	2	10	2	30	4	480	460	19	100
L6	R448A	2702	195	210	---	---	140	180	---	---	75	215	25	2	10	2	30	4	540	580	22	100
L6	R448A	3002	195	210	---	---	140	180	---	---	75	215	25	2	10	2	30	4	560	660	23	100
L6	R449A	602	195	210	---	---	140	180	---	---	75	215	25	2	10	2	30	4	580	720	15	100
L6	R449A	752	195	210	---	---	140	180	---	---	75	215	25	2	10	2	30	4	320	300	15	100
L6	R449A	902	195	210	---	---	140	180	---	---	75	215	25	2	10	2	30	4	350	320	15	100
L6	R449A	1002	195	210	---	---	140	180	---	---	75	215	25	2	10	2	30	4	400	360	15	100
L6	R449A	1202	195	210	---	---	140	180	---	---	75	215	25	2	10	2	30	4	410	380	15	100
L6	R449A	1502	195	210	---	---	140	180	---	---	75	215	25	2	10	2	30	4	450	420	16	100
L6	R449A	2202	195	210	---	---	140	180	---	---	75	215	25	2	10	2	30	4	480	460	19	100
L6	R449A	2702	195	210	---	---	140	180	---	---	75	215	25	2	10	2	30	4	540	580	22	100
L6	R449A	3002	195	210	---	---	140	180	---	---	75	215	25	2	10	2	30	4	560	660	23	100
L6	R407A	602	190	205	---	---	135	175	---	---	75	210	25	2	7	0	30	4	580	720	15	100
L6	R407A	752	190	205	---	---	135	175	---	---	75	210	25	2	7	0	30	4	320	300	15	100
L6	R407A	902	190	205	---	---	135	175	---	---	75	210	25	2	7	0	30	4	350	320	15	100

Factory Default Settings

Legacy Model Factory Default Settings (cont.)

APPLICATION	REFRIGERANT	MODEL SIZE	Fan Cycle Settings (Liquid Pressure, PRES), psig								DFT 1								CAREL		ALCO	
			Fan 1	Fan 2	Fan 3	Fan 4	Fan 1	Fan 2	Fan 3	Fan 4	DFT 2	DEFP	DEFT	EQU	LPSH	LPSL	FZET	FZTM	PRFS	PRFS	PRUI	DFIO
			ON	ON	ON	ON	OFF	OFF	OFF	OFF	°F	psig	Min.	Min.	psig	psig	°F	Min.				
L6	R407A	1002	190	205	---	---	135	175	---	---	75	210	25	2	7	0	30	4	410	380	15	100
L6	R407A	1202	190	205	---	---	135	175	---	---	75	210	25	2	7	0	30	4	450	420	15	100
L6	R407A	1502	190	205	---	---	135	175	---	---	75	210	25	2	7	0	30	4	480	460	16	100
L6	R407A	2202	190	205	---	---	135	175	---	---	75	210	25	2	7	0	30	4	540	580	19	100
L6	R407A	2702	190	205	---	---	135	175	---	---	75	210	25	2	7	0	30	4	560	660	22	100
L6	R407A	3002	190	205	---	---	135	175	---	---	75	210	25	2	7	0	30	4	580	720	23	100
L6	R407C	602	180	195	---	---	130	165	---	---	75	210	25	2	7	0	30	4	320	300	15	100
L6	R407C	752	180	195	---	---	130	165	---	---	75	210	25	2	7	0	30	4	350	320	15	100
L6	R407C	902	180	195	---	---	130	165	---	---	75	210	25	2	7	0	30	4	400	360	15	100
L6	R407C	1002	180	195	---	---	130	165	---	---	75	210	25	2	7	0	30	4	410	380	15	100
L6	R407C	1202	180	195	---	---	130	165	---	---	75	210	25	2	7	0	30	4	450	420	15	100
L6	R407C	1502	180	195	---	---	130	165	---	---	75	210	25	2	7	0	30	4	480	460	16	100
L6	R407C	2202	180	195	---	---	130	165	---	---	75	210	25	2	7	0	30	4	540	580	19	100
L6	R407C	2702	180	195	---	---	130	165	---	---	75	210	25	2	7	0	30	4	560	660	22	100
L6	R407C	3002	180	195	---	---	130	165	---	---	75	210	25	2	7	0	30	4	580	720	23	100
L6	R407F	602	200	215	---	---	145	185	---	---	75	215	25	2	7	0	30	4	320	300	15	100
L6	R407F	752	200	215	---	---	145	185	---	---	75	215	25	2	7	0	30	4	350	320	15	100
L6	R407F	902	200	215	---	---	145	185	---	---	75	215	25	2	7	0	30	4	400	360	15	100
L6	R407F	1002	200	215	---	---	145	185	---	---	75	215	25	2	7	0	30	4	410	380	15	100
L6	R407F	1202	200	215	---	---	145	185	---	---	75	215	25	2	7	0	30	4	450	420	15	100
L6	R407F	1502	200	215	---	---	145	185	---	---	75	215	25	2	7	0	30	4	480	460	16	100
L6	R407F	2202	200	215	---	---	145	185	---	---	75	215	25	2	7	0	30	4	540	580	19	100
L6	R407F	2702	200	215	---	---	145	185	---	---	75	215	25	2	7	0	30	4	560	660	22	100
L6	R407F	3002	200	215	---	---	145	185	---	---	75	215	25	2	7	0	30	4	580	720	23	100

- DEFP - Defrost Termination Pressure
- DEFT - Defrost Failsafe Time
- EQU - Equalizing Time
- LPSH - Low Pressure Switch Cut In
- LPSL - Low Pressure Switch Cut Out
- FZET - Evaporator Refreeze Temperature
- FZTM - Evaporator Refreeze Maximum Time
- DFT - Defrost Termination Temperature
- PRFS - Pressure Regulator Full Scale Range Setting
- PRUI - Electronic Valve Update Interval (in seconds)
- DFIO - Defrost Initial Valve Opening Position (% open)
- MT - Medium Temperature
- LT - Low Temperature

**Drawing 29326701 indicates, " Valve has been qualified by Heatcraft for a minimum room temperature of -30C (-22F) and a minimum refrigerant temperature of -35C (-31F)

***Suction Pressure Transducer, 28911202, (0-300 psia)

Factory Default Settings

Meet Minimum AWEF Model Factory Default Settings

APPLICATION	REFRIGERANT	MODEL SIZE	Fan Cycle Settings (Liquid Pressure, PRES), psig								DFT 1								CAREL		ALCO	
			Fan 1	Fan 2	Fan 3	Fan 4	Fan 1	Fan 2	Fan 3	Fan 4	DFT 2	DEFP	DEFT	EQU	LPSH	LPSL	FZET	FZTM	PRFS	PRFS	PRU	DFIO
			ON	ON	ON	ON	OFF	OFF	OFF	OFF	°F	psig	Min.	Min.	psig	psig	°F	Min.				
MT	R22	0077, 0078	155	170	—	—	110	145	—	—	85	210	25	2	16	6	35	4	320	300	15	100
MT	R22	0082	155	170	—	—	110	145	—	—	85	210	25	2	16	6	35	4	320	300	15	100
MT	R22	0102	155	170	—	—	110	145	—	—	85	210	25	2	16	6	35	4	350	320	15	100
MT	R22	0122	155	170	—	—	110	145	—	—	85	210	25	2	16	6	35	4	380	340	15	100
MT	R22	0152	155	170	—	—	110	145	—	—	85	210	25	2	16	6	35	4	410	380	15	100
MT	R22	0202	155	170	—	—	110	145	—	—	85	210	25	2	16	6	35	4	470	440	15	100
MT	R22	0252	155	170	180	—	110	145	155	—	85	210	25	2	16	6	35	4	510	520	17	100
MT	R22	0302	155	170	180	—	110	145	155	—	85	210	25	2	16	6	35	4	550	600	20	100
MT	R22	0352	155	170	180	—	110	145	155	—	85	210	25	2	16	6	35	4	570	700	23	100
MT	R22	0402	155	170	180	195	110	145	155	170	85	210	25	2	16	6	35	4	590	780	25	100
MT	R404A	0077, 0078	190	205	—	—	135	175	—	—	85	210	25	2	24	10	35	4	320	300	15	100
MT	R404A	0082	190	205	—	—	135	175	—	—	85	210	25	2	24	10	35	4	320	300	15	100
MT	R404A	0102	190	205	—	—	135	175	—	—	85	210	25	2	24	10	35	4	350	320	15	100
MT	R404A	0122	190	205	—	—	135	175	—	—	85	210	25	2	24	10	35	4	380	340	15	100
MT	R404A	0152	190	205	—	—	135	175	—	—	85	210	25	2	24	10	35	4	410	380	15	100
MT	R404A	0202	190	205	—	—	135	175	—	—	85	210	25	2	24	10	35	4	470	440	15	100
MT	R404A	0252	190	205	220	—	135	175	190	—	85	210	25	2	24	10	35	4	510	520	17	100
MT	R404A	0302	190	205	220	—	135	175	190	—	85	210	25	2	24	10	35	4	550	600	20	100
MT	R404A	0352	190	205	220	—	135	175	190	—	85	210	25	2	24	10	35	4	570	700	23	100
MT	R404A	0402	190	205	220	235	135	175	190	205	85	210	25	2	24	10	35	4	590	780	25	100
MT	R507	0077, 0078	195	210	—	—	140	180	—	—	85	210	25	2	26	11	35	4	320	300	15	100
MT	R507	0082	195	210	—	—	140	180	—	—	85	210	25	2	26	11	35	4	320	300	15	100
MT	R507	0102	195	210	—	—	140	180	—	—	85	210	25	2	26	11	35	4	350	320	15	100
MT	R507	0122	195	210	—	—	140	180	—	—	85	210	25	2	26	11	35	4	380	340	15	100
MT	R507	0152	195	210	—	—	140	180	—	—	85	210	25	2	26	11	35	4	410	380	15	100
MT	R507	0202	195	210	—	—	140	180	—	—	85	210	25	2	26	11	35	4	470	440	15	100
MT	R507	0252	195	210	225	—	140	180	195	—	85	210	25	2	26	11	35	4	510	520	17	100
MT	R507	0302	195	210	225	—	140	180	195	—	85	210	25	2	26	11	35	4	550	600	20	100
MT	R507	0352	195	210	225	—	140	180	195	—	85	210	25	2	26	11	35	4	570	700	23	100
MT	R507	0402	195	210	225	245	140	180	195	210	85	210	25	2	26	11	35	4	590	780	25	100
MT	R407A	0077, 0078	190	205	—	—	135	175	—	—	85	210	25	2	15	3	35	4	320	300	15	100
MT	R407A	0082	190	205	—	—	135	175	—	—	85	210	25	2	15	3	35	4	320	300	15	100
MT	R407A	0102	190	205	—	—	135	175	—	—	85	210	25	2	15	3	35	4	350	320	15	100
MT	R407A	0122	190	205	—	—	135	175	—	—	85	210	25	2	15	3	35	4	380	340	15	100
MT	R407A	0152	190	205	—	—	135	175	—	—	85	210	25	2	15	3	35	4	410	380	15	100
MT	R407A	0202	190	205	—	—	135	175	—	—	85	210	25	2	15	3	35	4	470	440	15	100
MT	R407A	0252	190	205	220	—	135	175	190	—	85	210	25	2	15	3	35	4	510	520	17	100
MT	R407A	0302	190	205	220	—	135	175	190	—	85	210	25	2	15	3	35	4	550	600	20	100
MT	R407A	0352	190	205	220	—	135	175	190	—	85	210	25	2	15	3	35	4	570	700	23	100
MT	R407A	0402	190	205	220	235	135	175	190	205	85	210	25	2	15	3	35	4	590	780	25	100

Factory Default Settings

Meet Minimum AWEF Model Factory Default Settings (cont.)

APPLICATION	REFRIGERANT	MODEL SIZE	Fan Cycle Settings (Liquid Pressure, PRES), psig								DFT 1								CAREL	ALCO		
			Fan 1	Fan 2	Fan 3	Fan 4	Fan 1	Fan 2	Fan 3	Fan 4	DFT 2	DEFP	DEFT	EQU	LPSH	LPSL	FZET	FZTM				
			ON	ON	ON	ON	OFF	OFF	OFF	OFF	°F	psig	Min.	Min.	psig	psig	°F	Min.	PRFS	PRFS	PRUI	DFIO
MT	R407C	0077, 0078	180	195	—	—	130	165	—	—	85	210	25	2	12	1	35	4	320	300	15	100
MT	R407C	0082	180	195	—	—	130	165	—	—	85	210	25	2	12	1	35	4	320	300	15	100
MT	R407C	0102	180	195	—	—	130	165	—	—	85	210	25	2	12	1	35	4	350	320	15	100
MT	R407C	0122	180	195	—	—	130	165	—	—	85	210	25	2	12	1	35	4	380	340	15	100
MT	R407C	0152	180	195	—	—	130	165	—	—	85	210	25	2	12	1	35	4	410	380	15	100
MT	R407C	0202	180	195	—	—	130	165	—	—	85	210	25	2	12	1	35	4	470	440	15	100
MT	R407C	0252	180	195	210	—	130	165	180	—	85	210	25	2	12	1	35	4	510	520	17	100
MT	R407C	0302	180	195	210	—	130	165	180	—	85	210	25	2	12	1	35	4	550	600	20	100
MT	R407C	0352	180	195	210	—	130	165	180	—	85	210	25	2	12	1	35	4	570	700	23	100
MT	R407C	0402	180	195	210	225	130	165	180	195	85	210	25	2	12	1	35	4	590	780	25	100
MT	R407F	0077, 0078	200	215	—	—	145	185	—	—	85	215	25	2	16	4	35	4	320	300	15	100
MT	R407F	0082	200	215	—	—	145	185	—	—	85	215	25	2	16	4	35	4	320	300	15	100
MT	R407F	0102	200	215	—	—	145	185	—	—	85	215	25	2	16	4	35	4	350	320	15	100
MT	R407F	0122	200	215	—	—	145	185	—	—	85	215	25	2	16	4	35	4	380	340	15	100
MT	R407F	0152	200	215	—	—	145	185	—	—	85	215	25	2	16	4	35	4	410	380	15	100
MT	R407F	0202	200	215	—	—	145	185	—	—	85	215	25	2	16	4	35	4	470	440	15	100
MT	R407F	0252	200	215	230	—	145	185	200	—	85	215	25	2	16	4	35	4	510	520	17	100
MT	R407F	0302	200	215	230	—	145	185	200	—	85	215	25	2	16	4	35	4	550	600	20	100
MT	R407F	0352	200	215	230	—	145	185	200	—	85	215	25	2	16	4	35	4	570	700	23	100
MT	R407F	0402	200	215	230	250	145	185	200	215	85	215	25	2	16	4	35	4	590	780	25	100
LT	R404A	0062	155	170	—	—	100	140	—	—	75	210	25	2	10	2	30	4	320	300	15	100
LT	R404A	0077	155	170	—	—	100	140	—	—	75	210	25	2	10	2	30	4	350	320	15	100
LT	R404A	0092	155	170	—	—	100	140	—	—	75	210	25	2	10	2	30	4	400	360	15	100
LT	R404A	0102	155	170	—	—	100	140	—	—	75	210	25	2	10	2	30	4	410	380	15	100
LT	R404A	0122	155	170	—	—	100	140	—	—	75	210	25	2	10	2	30	4	450	420	15	100
LT	R404A	0152	155	170	—	—	100	140	—	—	75	210	25	2	10	2	30	4	480	460	16	100
LT	R404A	0222	155	170	—	—	100	140	—	—	75	210	25	2	10	2	30	4	540	580	19	100
LT	R404A	0272	155	170	—	—	100	140	—	—	75	210	25	2	10	2	30	4	560	660	22	100
LT	R404A	0302	155	170	—	—	100	140	—	—	75	210	25	2	10	2	30	4	580	720	23	100
LT	R507	0062	155	170	—	—	100	140	—	—	75	180	25	2	11	2	30	4	320	300	15	100
LT	R507	0077	155	170	—	—	100	140	—	—	75	180	25	2	11	2	30	4	350	320	15	100
LT	R507	0092	155	170	—	—	100	140	—	—	75	180	25	2	11	2	30	4	400	360	15	100
LT	R507	0102	155	170	—	—	100	140	—	—	75	180	25	2	11	2	30	4	410	380	15	100
LT	R507	0122	155	170	—	—	100	140	—	—	75	180	25	2	11	2	30	4	450	420	15	100
LT	R507	0152	155	170	—	—	100	140	—	—	75	180	25	2	11	2	30	4	480	460	16	100
LT	R507	0222	155	170	—	—	100	140	—	—	75	180	25	2	11	2	30	4	540	580	19	100
LT	R507	0272	155	170	—	—	100	140	—	—	75	180	25	2	11	2	30	4	560	660	22	100
LT	R507	0302	155	170	—	—	100	140	—	—	75	180	25	2	11	2	30	4	580	720	23	100
MT	R448A	0077, 0078	195	210	—	—	140	180	—	—	85	215	25	2	26	10	35	4	320	300	15	100
MT	R448A	0082	195	210	—	—	140	180	—	—	85	215	25	2	26	10	35	4	320	300	15	100

Factory Default Settings

Meet Minimum AWEF Model Factory Default Settings (cont.)

APPLICATION	REFRIGERANT	MODEL SIZE	Fan Cycle Settings (Liquid Pressure, PRES), psig								DFT 1								CAREL		ALGO	
			Fan 1	Fan 2	Fan 3	Fan 4	Fan 1	Fan 2	Fan 3	Fan 4	DFT 2	DEFP	DEFT	EQUO	LPSH	LPSL	FZET	FZTM	PRFS	PRFS	PRUI	DFIO
			ON	ON	ON	ON	OFF	OFF	OFF	OFF	°F	psig	Min.	Min.	psig	psig	°F	Min.	PRFS	PRFS	PRUI	DFIO
MT	R448A	0102	195	210	—	—	140	180	—	—	85	215	25	2	26	10	35	4	350	320	15	100
MT	R448A	0122	195	210	—	—	140	180	—	—	85	215	25	2	26	10	35	4	380	340	15	100
MT	R448A	0152	195	210	—	—	140	180	—	—	85	215	25	2	26	10	35	4	410	380	15	100
MT	R448A	0202	195	210	—	—	140	180	—	—	85	215	25	2	26	10	35	4	470	440	15	100
MT	R448A	0252	195	210	225	—	140	180	195	—	85	215	25	2	26	10	35	4	510	520	17	100
MT	R448A	0302	195	210	225	—	140	180	195	—	85	215	25	2	26	10	35	4	550	600	20	100
MT	R448A	0352	195	210	225	—	140	180	195	—	85	215	25	2	26	10	35	4	570	700	23	100
MT	R448A	0402	195	210	225	240	140	180	195	210	85	215	25	2	26	10	35	4	590	780	25	100
MT	R449A	0077, 0078	195	210	—	—	140	180	—	—	85	215	25	2	26	10	35	4	320	300	15	100
MT	R449A	0082	195	210	—	—	140	180	—	—	85	215	25	2	26	10	35	4	320	300	15	100
MT	R449A	0102	195	210	—	—	140	180	—	—	85	215	25	2	26	10	35	4	350	320	15	100
MT	R449A	0122	195	210	—	—	140	180	—	—	85	215	25	2	26	10	35	4	380	340	15	100
MT	R449A	0152	195	210	—	—	140	180	—	—	85	215	25	2	26	10	35	4	410	380	15	100
MT	R449A	0202	195	210	—	—	140	180	—	—	85	215	25	2	26	10	35	4	470	440	15	100
MT	R449A	0252	195	210	225	—	140	180	195	—	85	215	25	2	26	10	35	4	510	520	17	100
MT	R449A	0302	195	210	225	—	140	180	195	—	85	215	25	2	26	10	35	4	550	600	20	100
MT	R449A	0352	195	210	225	—	140	180	195	—	85	215	25	2	26	10	35	4	570	700	23	100
MT	R449A	0402	195	210	225	240	140	180	195	210	85	215	25	2	26	10	35	4	590	780	25	100
LT	R448A	0062	155	170	—	—	100	140	—	—	75	215	25	2	10	2	30	4	320	300	15	100
LT	R448A	0077	155	170	—	—	100	140	—	—	75	215	25	2	10	2	30	4	350	320	15	100
LT	R448A	0092	155	170	—	—	100	140	—	—	75	215	25	2	10	2	30	4	400	360	15	100
LT	R448A	0102	155	170	—	—	100	140	—	—	75	215	25	2	10	2	30	4	410	380	15	100
LT	R448A	0122	155	170	—	—	100	140	—	—	75	215	25	2	10	2	30	4	450	420	15	100
LT	R448A	0152	155	170	—	—	100	140	—	—	75	215	25	2	10	2	30	4	480	460	16	100
LT	R448A	0222	155	170	—	—	100	140	—	—	75	215	25	2	10	2	30	4	540	580	19	100
LT	R448A	0272	155	170	—	—	100	140	—	—	75	215	25	2	10	2	30	4	560	660	22	100
LT	R448A	0302	155	170	—	—	100	140	—	—	75	215	25	2	10	2	30	4	580	720	23	100
LT	R449A	0062	155	170	—	—	100	140	—	—	75	215	25	2	10	2	30	4	320	300	15	100
LT	R449A	0077	155	170	—	—	100	140	—	—	75	215	25	2	10	2	30	4	350	320	15	100
LT	R449A	0092	155	170	—	—	100	140	—	—	75	215	25	2	10	2	30	4	400	360	15	100
LT	R449A	0102	155	170	—	—	100	140	—	—	75	215	25	2	10	2	30	4	410	380	15	100
LT	R449A	0122	155	170	—	—	100	140	—	—	75	215	25	2	10	2	30	4	450	420	15	100
LT	R449A	0152	155	170	—	—	100	140	—	—	75	215	25	2	10	2	30	4	480	460	16	100
LT	R449A	0222	155	170	—	—	100	140	—	—	75	215	25	2	10	2	30	4	540	580	19	100
LT	R449A	0272	155	170	—	—	100	140	—	—	75	215	25	2	10	2	30	4	560	660	22	100
LT	R449A	0302	155	170	—	—	100	140	—	—	75	215	25	2	10	2	30	4	580	720	23	100
LT	R407A	0062	155	170	—	—	100	140	—	—	75	210	25	2	7	0	30	4	320	300	15	100
LT	R407A	0077	155	170	—	—	100	140	—	—	75	210	25	2	7	0	30	4	350	320	15	100
LT	R407A	0092	155	170	—	—	100	140	—	—	75	210	25	2	7	0	30	4	400	360	15	100
LT	R407A	0102	155	170	—	—	100	140	—	—	75	210	25	2	7	0	30	4	410	380	15	100
LT	R407A	0122	155	170	—	—	100	140	—	—	75	210	25	2	7	0	30	4	450	420	15	100
LT	R407A	0152	155	170	—	—	100	140	—	—	75	210	25	2	7	0	30	4	480	460	16	100

Factory Default Settings

Meet Minimum AWEF Model Factory Default Settings (cont.)

APPLICATION	REFRIGERANT	MODEL SIZE	Fan Cycle Settings (Liquid Pressure, PRES), psig								DFT 1								CAREL	ALCO		
			Fan 1	Fan 2	Fan 3	Fan 4	Fan 1	Fan 2	Fan 3	Fan 4	DFT 2	DEFP	DEFT	EQU	LPSH	LPSL	FZET	FZTM				
			ON	ON	ON	ON	OFF	OFF	OFF	OFF	°F	psig	Min.	Min.	psig	psig	°F	Min.	PRFS	PRFS	PRUI	DFIO
LT	R407A	0222	155	170	—	—	100	140	—	—	75	210	25	2	7	0	30	4	540	580	19	100
LT	R407A	0272	155	170	—	—	100	140	—	—	75	210	25	2	7	0	30	4	560	660	22	100
LT	R407A	0302	155	170	—	—	100	140	—	—	75	210	25	2	7	0	30	4	580	720	23	100
LT	R407C	0062	150	165	—	—	100	135	—	—	75	210	25	2	7	0	30	4	320	300	15	100
LT	R407C	0077	150	165	—	—	100	135	—	—	75	210	25	2	7	0	30	4	350	320	15	100
LT	R407C	0092	150	165	—	—	100	135	—	—	75	210	25	2	7	0	30	4	400	360	15	100
LT	R407C	0102	150	165	—	—	100	135	—	—	75	210	25	2	7	0	30	4	410	380	15	100
LT	R407C	0122	150	165	—	—	100	135	—	—	75	210	25	2	7	0	30	4	450	420	15	100
LT	R407C	0152	150	165	—	—	100	135	—	—	75	210	25	2	7	0	30	4	480	460	16	100
LT	R407C	0222	150	165	—	—	100	135	—	—	75	210	25	2	7	0	30	4	540	580	19	100
LT	R407C	0272	150	165	—	—	100	135	—	—	75	210	25	2	7	0	30	4	560	660	22	100
LT	R407C	0302	150	165	—	—	100	135	—	—	75	210	25	2	7	0	30	4	580	720	23	100
LT	R407F	0062	155	170	—	—	100	140	—	—	75	215	25	2	7	0	30	4	320	300	15	100
LT	R407F	0077	155	170	—	—	100	140	—	—	75	215	25	2	7	0	30	4	350	320	15	100
LT	R407F	0092	155	170	—	—	100	140	—	—	75	215	25	2	7	0	30	4	400	360	15	100
LT	R407F	0102	155	170	—	—	100	140	—	—	75	215	25	2	7	0	30	4	410	380	15	100
LT	R407F	0122	155	170	—	—	100	140	—	—	75	215	25	2	7	0	30	4	450	420	15	100
LT	R407F	0152	155	170	—	—	100	140	—	—	75	215	25	2	7	0	30	4	480	460	16	100
LT	R407F	0222	155	170	—	—	100	140	—	—	75	215	25	2	7	0	30	4	540	580	19	100
LT	R407F	0272	155	170	—	—	100	140	—	—	75	215	25	2	7	0	30	4	560	660	22	100
LT	R407F	0302	155	170	—	—	100	140	—	—	75	215	25	2	7	0	30	4	580	720	23	100

- DEFP - Defrost Termination Pressure
- DEFT - Defrost Failsafe Time
- EQU - Equalizing Time
- LPSH - Low Pressure Switch Cut In
- LPSL - Low Pressure Switch Cut Out
- FZET - Evaporator Refreeze Temperature
- FZTM - Evaporator Refreeze Maximum Time
- DFT - Defrost Termination Temperature
- PRFS - Pressure Regulator Full Scale Range Setting
- PRUI - Electronic Valve Update Interval (in seconds)
- DFIO - Defrost Initial Valve Opening Position (% open)
- MT - Medium Temperature
- LT - Low Temperature

**Drawing 29326701 indicates, " Valve has been qualified by Heatcraft for a minimum room temperature of -30C (-22F) and a minimum refrigerant temperature of -35C (-31F)

***Suction Pressure Transducer, 28911202, (0-300 psia)

Mohave Control Board Comparison

FIRST GENERATION HRP# 28910301

SECOND GENERATION HRP# 28910302

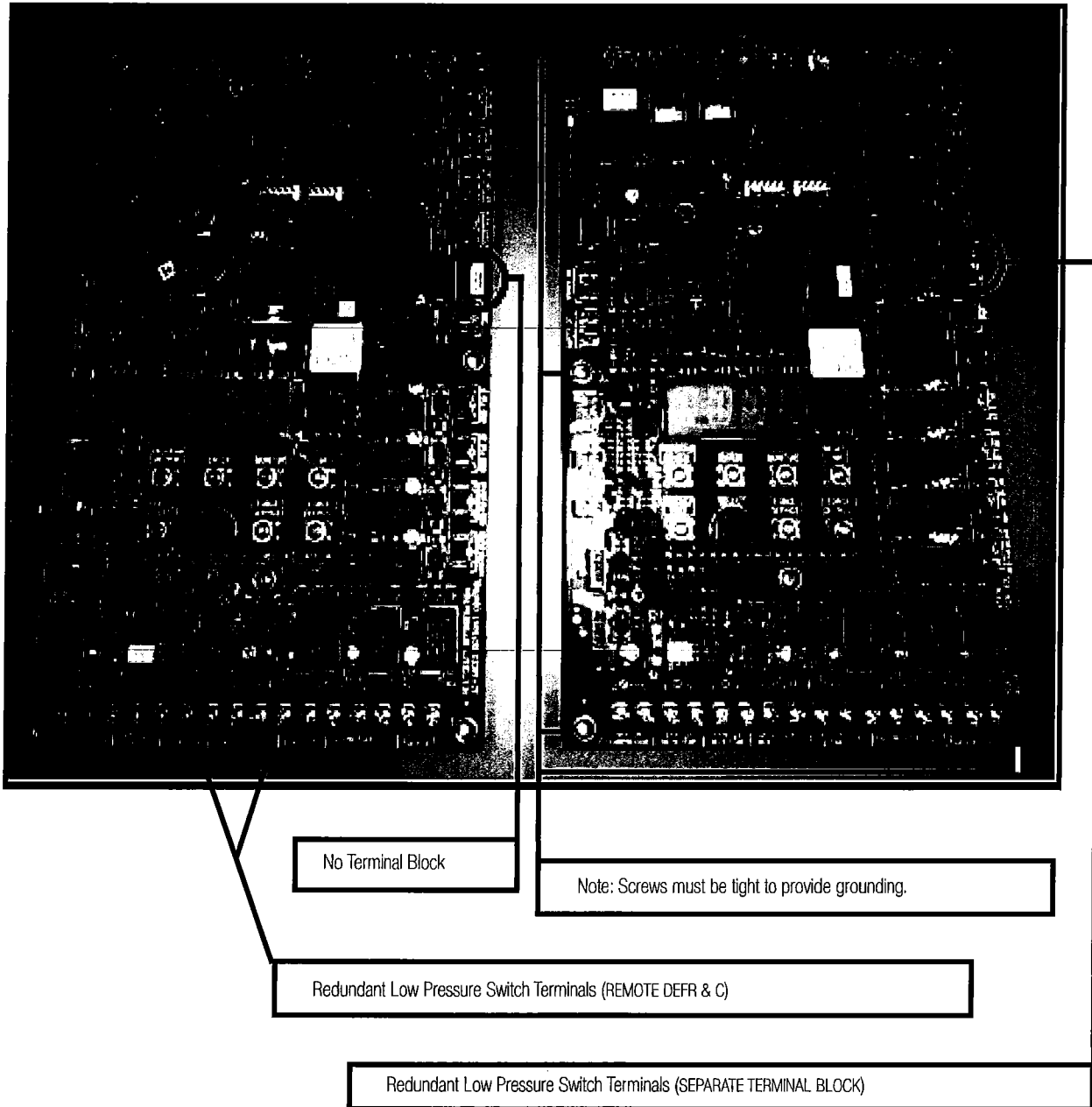

Service Part Note: Review wiring and mounting differences when replacing a First Gen Board with a Second Gen Board.

Electronic Pressure Regulator Comparison

MANUFACTURER: ALCO
PRODUCTION THROUGH OCT. 2011
HRP# 29330501

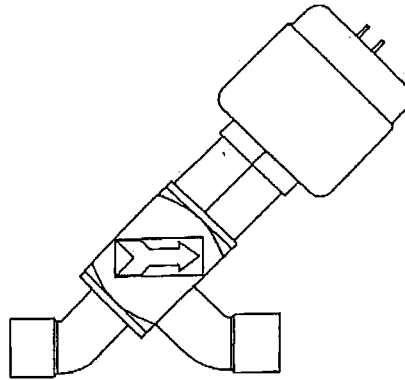

MANUFACTURER: CAREL
CURRENT PRODUCTION
HRP# 29326701

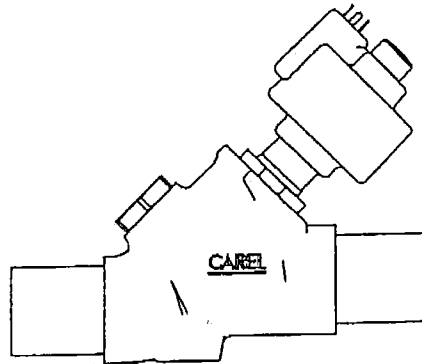

SEE PAGE 41 OF INSTALLATION MANUAL FOR LOCATION OF PRESSURE
REGULATOR IN CONDENSING UNIT. DETERMINE THE MANUFACTURER
BASED UPON THIS PICTORIAL.

Heatcraft Mohave Control Modbus Definitions

NOTE: For this device, ModBus message frames must be no larger than 256 bytes

NOTE: For ModBus commands, temperatures are always degrees F, pressures are always psia, and times are always 24-hour HHMM

Discrete Inputs - CMD 0x02 (Read)

	Input Address	Byte Addr.	Bit Addr.
"Enter" pushbutton	0	0	0
"Clear/Test" pushbutton	1	0	1
"Program Review" pushbutton	2	0	2
"Force Service" pushbutton	3	0	3
"Monitor" pushbutton	4	0	4
"Force Defrost" pushbutton	5	0	5
"Reset Time" pushbutton	6	0	6
Service Switch contacts	7	0	7
Safety Switch contacts	8	1	0
CU Suction Pressure switch contacts	9	1	1
T-Stat contacts	10	1	2
Beacon I/F current sense	11	1	3
Remote Defrost switch contacts	12	1	4

Coils - CMD 0x01 (Read), CMD 0x05 (Single Write) CMD 0x0F (Multiple Write)

	Coil Address	Byte Addr.	Bit Addr.
Beacon "Low Pressure Switch" output	0	0	0
Evaporator Heater relay	1	0	1
Liquid Line Solenoids relay	2	0	2
Evaporator Fan relay	3	0	3
Condenser Fan 4 relay	4	0	4
Condenser Fan 3 relay	5	0	5
Condenser Fan 2 relay	6	0	6
Condenser Fan 1 relay	7	0	7
Alarm relay	8	1	0
Compressor relay	9	1	1
Bypass Valve relay	10	1	2
Suction Solenoid relay	11	1	3
Defrost Solenoid relay	12	1	4
3-Way Valve relay	13	1	5

Input Registers - CMD 0x04 (Read)

	Data Type	Word Addr.	Label
Suction Temperature (-55 to +125 degrees F)	Word, signed	0	SUC T
Ambient Temperature (-55 to +125 degrees F)	Word, signed	1	AMBT
Auxilliary Temperature (-55 to +125 degrees F)	Word, signed	2	AUX T

Mohave Hot Gas Control Modbus Definitions

Suction Pressure (0 to 300 psia), displayed as 30" Hg to 285 psig	Word	3	<i>SUCP</i>
Liquid Pressure (0 to 500 psia), displayed as 30" Hg to 485 psig	Word	4	<i>LIQP</i>
Evap 1 Defrost Temp (-55 to +125 degrees F)	Word, signed	5	<i>E1DT</i>
Evap 2 Defrost Temp (-55 to +125 degrees F)	Word, signed	6	<i>E2DT</i>
Saturated Suction Temp (-55 to +125 degrees F)	Word, signed	7	<i>SSUC</i>
Suction Superheat (-128 to +127 degrees F)	Word, signed	8	<i>SUPH</i>
Regulator Valve position (0 to 820 steps)	Word	9	<i>VALP</i>
AC input voltage (0 to 315 volts*10), e.g. 243 = 24.3 Vac	Word	10	<i>ACIN</i>
SELECT control position (0=full CCW to 255=full CW)	Word	11	
Errors (bit-packed):	Word	12	
0x0001 CU Suction Temperature sensor error			<i>Err 1</i>
0x0002 CU Ambient Temperature sensor error			<i>Err 2</i>
0x0004 CU Aux Temperature sensor error			<i>Err 3</i>
0x0008 CU Suction Pressure sensor error			<i>Err 4</i>
0x0010 CU Liquid Pressure sensor error			<i>Err 5</i>
0x0020 Evaporator #1 Defrost Temperature sensor error			<i>Err 6</i>
0x0040 Evaporator #2 Defrost Temperature sensor error			<i>Err 7</i>
0x0080 CU Suction Pressure switch error			<i>Err 8</i>
0x0100 Safety Circuit shut-down error			<i>Err 9</i>
0x0200 Prolonged low suction pressure shut-down error			<i>Er 10</i>
0x0400 Low-pressure start-up error			<i>Er 11</i>
0x0800 High-pressure start-up error			<i>Er 12</i>
0x1000 Defrost pump-down error			<i>Er 13</i>
(0x2000 to 0x8000 not used)			
Alarms (bit-packed):	Word	13	
0x0001 Persistent input sensor failure alarm			<i>Alr 1</i>
0x0002 CU Suction Pressure sensor & switch failure alarm			<i>Alr 2</i>
0x0004 repeated safety circuit open condition alarm			<i>Alr 3</i>
0x0008 Persistent low- or high-pressure startup failure alarm			<i>Alr 4</i>
0x0010 High CU Aux (Room) Temperature alarm			<i>Alr 5</i>
0x0020 Low CU Aux (Room) Temperature alarm			<i>Alr 6</i>
(0x0040 to 0x8000 not used)			
Software Version (RRrr - MAJOR.minor revision); e.g. 107 = 1.07	Word	14	<i>VERS</i>
Operating Mode (0=Off, 1=Delay, 2=Cooling, 3=Pump-Down, 4=Defrost1, 5=Defrost2, 6=Defrost3, 7=DefrostA, 8=Re-Freeze, 9=Test, 10=Service)	Word	15	<i>OFF DELY COOL PUMP DEF 1 DEF2 DEF3 DEFA FREEZ TEST SERV</i>
Status/Configuration (bit-packed):	Word	16	
0x0001 Displayed temperature units (0=degrees F, 1=degrees C)			
0x0002 Displayed time mode (0=12 hour, 1=24 hour)			
0x0004 Application Type (0=Low temp, 1=Medium temp)			
0x0008 Evaporator fan mode if not cooling (0=off, 1=on)			
0x0010 Expert mode (0=off, 1=on)			<i>XPRT</i>
0x0020 Parameter lock mode (0=unlocked, 1=locked)			
0x0040 Service mode configured (0=off, 1=on)			
0x0080 CU Aux Room Temperature control (0=off, 1=on)			
0x0100 CU Aux Temperature sensor attached (0=no, 1=yes)			
0x0200 Evaporator #2 temperature sensor attached (0=no, 1=yes)			
0x1000 Remote control (0=off, 1=on)			
0x2000 Error status (0=no errors, 1=one or more errors detected)			
0x4000 Alarm status (0=no alarms, 1=one or more alarms detected)			
(0x0400, 0x0800, 0x8000 not used)			

Heatcraft Mohave Control Modbus Definitions

Last elapsed defrost time (minutes)	Word	17	DFTM
Compressor cycles since midnight (0 to 255)	Word	18	CCYC
Run time since midnight (0000 to 2359 HHMM)	Word	19	RnTM
Elapsed time since last defrost (00000 to 25559 HHHMM)	Word	20	ETLD
Run time since last defrost (00000 to 25559 HHHMM)	Word	21	RTL D

Holding Registers - CMD 0x03 (Read), CMD 0x06 (Single Write) CMD 0x10 (Multiple Write)

	Data Type	Word Addr.	Label
Display Right char. (7-bit ASCII + 0x80 DP)	Word	0	
Display Ctr-Right char. (7-bit ASCII + 0x80 DP)	Word	1	
Display Ctr-Left char. (7-bit ASCII + 0x80 DP)	Word	2	
Display Left char. (7-bit ASCII + 0x80 DP)	Word	3	
Time of Day (0000 to 2359 HHMM)	Word	4	CLKH CLKM
Pressure Regulator setpoint (0 to 820 steps)	Word	5	
revised Refrigerant Type (0=R-22, 1=R-404A, 2=R-507, 3=R-407A, 4=R-407C, 5=R-407F, 6=R-448A, 7=R-449A)	Word	6	REFR
Application Type (0=Low temp, 1=Medium temp)	Word	7	APPL
Model Number (500 to 5000)	Word	8	MODL
Displayed temperature units (0=degrees F, 1=degrees C)	Word	9	'F 'C
Displayed time mode (0=12 hour, 1=24 hour)	Word	10	1224
Evaporator fan mode if not cooling (0=off, 1=on)	Word	11	EVPF
Parameter lock mode (0=unlocked, 1=locked)	Word	12	
Number of evaporators (1 or 2)	Word	13	
Evaporator #1 defrost termination temp (+50 to +100 degrees F)	Word, signed	14	DF11
Evaporator #2 defrost termination temp (+50 to +100 degrees F)	Word, signed	15	DF12
Defrost termination pressure (175 to 315 psia), displayed as 160 to 300 psig	Word	16	DEFP
Defrost override time limit (5 to 30 minutes)	Word	17	DEFT
Alarm condition duration (2 to 120 minutes)	Word	18	ALRT
Pressure Regulator full scale (100 to 820 steps)	Word	19	PRFS
Equalization time (1 to 10 minutes)	Word	20	EQU T
Low Pressure Switch high limit (15 to 45 psia), displayed as 0 to 30 psig	Word	21	LPSH
Low Pressure Switch low limit (15 to 45 psia), displayed as 0 to 30 psig	Word	22	LPSL
Evaporator re-freeze temperature threshold (+20 to +40 degrees F)	Word, signed	23	FZET
Normal valve update interval (10 to 30 seconds)	Word	24	PRUI
Initial defrost Pressure Regulator opening (50 to 100%)	Word	25	DFID
Evaporator re-freeze time limit (0 to 10 minutes)	Word	26	FZTM
Cooling mode LLS Pulsing time limit (0 to 15 minutes)	Word	27	LLSP
ESV/PR valve manufacturer (0=Carel or 1=Alco)	Word	28	VALM
CU Aux Room Temperature control (0=off, 1=on)	Word	29	AUX T
CU Aux Room Temperature setpoint (-25 to +50 degrees F)	Word, signed	30	BOX T
High CU Aux Temp Alarm threshold (-35 to +100 degrees F), +127 if disabled	Word, signed	31	ALRH
Low CU Aux Temp Alarm threshold (-35 to +100 degrees F), -128 if disabled	Word, signed	32	ALRL
Run-time defrost interval (0030 to 1200 HHMM), 0000 if disabled	Word	33	RTDF
Defrost #1 start time (0000 to 2330 HHMM), 2530 if not used	Word	34	DF01
Defrost #2 start time (0000 to 2330 HHMM), 2530 if not used	Word	35	DF02
Defrost #3 start time (0000 to 2330 HHMM), 2530 if not used	Word	36	DF03
Defrost #4 start time (0000 to 2330 HHMM), 2530 if not used	Word	37	DF04
Defrost #5 start time (0000 to 2330 HHMM), 2530 if not used	Word	38	DF05
Defrost #6 start time (0000 to 2330 HHMM), 2530 if not used	Word	39	DF06
Defrost #7 start time (0000 to 2330 HHMM), 2530 if not used	Word	40	DF07

Mohave Hot Gas Control Modbus Definitions

Defrost #8 start time (0000 to 2330 HHMM), 2530 if not used	Word	41	DF08
Defrost #9 start time (0000 to 2330 HHMM), 2530 if not used	Word	42	DF09
Defrost #10 start time (0000 to 2330 HHMM), 2530 if not used	Word	43	DF10
Defrost #11 start time (0000 to 2330 HHMM), 2530 if not used	Word	44	DF11
Defrost #12 start time (0000 to 2330 HHMM), 2530 if not used	Word	45	DF12
Number of CU fans (1 to 4)	Word	46	
CU Fan #1 mode (0=off, 1=on, 2=press. ctl., 3=temp. ctl.)	Word	47	FAN1
CU Fan #2 mode (0=off, 1=on, 2=press. ctl., 3=temp. ctl.)	Word	48	FAN2
CU Fan #3 mode (0=off, 1=on, 2=press. ctl., 3=temp. ctl.)	Word	49	FAN3
CU Fan #4 mode (0=off, 1=on, 2=press. ctl., 3=temp. ctl.)	Word	50	FAN4
CU Fan #1 On pressure (125 to 315 psia), displayed as 110 to 300 psig	Word	51	F10N
CU Fan #2 On pressure (125 to 315 psia), displayed as 110 to 300 psig	Word	52	F20N
CU Fan #3 On pressure (125 to 315 psia), displayed as 110 to 300 psig	Word	53	F30N
CU Fan #4 On pressure (125 to 315 psia), displayed as 110 to 300 psig	Word	54	F40N
CU Fan #1 Off pressure (125 to 315 psia), displayed as 110 to 300 psig	Word	55	F10F
CU Fan #2 Off pressure (125 to 315 psia), displayed as 110 to 300 psig	Word	56	F20F
CU Fan #3 Off pressure (125 to 315 psia), displayed as 110 to 300 psig	Word	57	F30F
CU Fan #4 Off pressure (125 to 315 psia), displayed as 110 to 300 psig	Word	58	F40F
CU Fan #1 On temperature (+30 to +90 degrees F)	Word, signed	59	F10N
CU Fan #2 On temperature (+30 to +90 degrees F)	Word, signed	60	F20N
CU Fan #3 On temperature (+30 to +90 degrees F)	Word, signed	61	F30N
CU Fan #4 On temperature (+30 to +90 degrees F)	Word, signed	62	F40N
CU Fan #1 Off temperature (+30 to +90 degrees F)	Word, signed	63	F10F
CU Fan #2 Off temperature (+30 to +90 degrees F)	Word, signed	64	F20F
CU Fan #3 Off temperature (+30 to +90 degrees F)	Word, signed	65	F30F
CU Fan #4 Off temperature (+30 to +90 degrees F)	Word, signed	66	F40F
(not used)	---	67 to 7999	
Remote Control (0xAA55=activate, 0xFF00=deactivate)	Word	8000	

NOTE: The Write Remote Control command with a data value of 'activate' is ignored unless the Mohave Control is in "Off" or "Service" modes

Diagnostic - CMD 0x08 (Read/Write)

	Sub-Function
Restart communications	0x01
Clear Counters and Diagnostic Register	0x0A
Read Bus Message Counter	0x0B
Read Bus Communication Error Counter	0x0C
Read Bus Exception Error Counter	0x0D
Read Slave Message Counter	0x0E
Read Slave No Response Counter	0x0F
Read Slave NAK Counter	0x10
Read Slave Busy Counter	0x11
Read Bus Character Overrun Counter	0x12
Clear Overrun Counter and Flag	0x14
Activate Remote Control mode	0xAA55
Deactivate Remote Control mode	0xFF00

NOTE: The Activate Remote Control command is ignored unless the Mohave Control is in "Off" or "Service" modes

Notes

Notes

Since product improvement is a continuing effort,
we reserve the right to make changes in specifications without notice.

Heatcraft Refrigeration Products LLC

2175 West Park Place Blvd. • Stone Mountain, GA 30087
770-465-5600 • Fax: 770-465-5990 • www.heatcraftrpd.com

