



# Installation and Operation Manual

Bulletin No. H-IM-PCS

October 2004

Part Number 25000102

(Replaces H-IM-72B, October 2004)

# Parallel Compressor Systems

## Table of Contents

<b>Introduction</b> .....	<b>3</b>	<b>Table 14. Oil Safety Switch</b> .....	<b>22</b>
Inspection		Table 15. Part Load Performance Multipliers	
Unit Designation		Table 16. Required Differential Pressure	
Model Definition		Three-Phase Voltage Monitor	
<b>System Warranty</b> .....	<b>4</b>	<b>Sight Glass &amp; Moisture Indicator</b> .....	<b>23</b>
Rigging		Figure 10. Sight Glass	
Location of Equipment - INDOOR		Safety Relief Devices	
Clearances		Figure 11. Direct Type Relief Valves	
Floor & Foundation Requirements		Figure 12. 3-Way Relief Valve	
Vibration Mounts		<b>Table 17. Henry Relief Valve Capacity Ratings</b> .....	<b>24</b>
Figure 1. Vibration Pad & Spring Isolator		Table 18. Discharge Piping Table	
Figure 2. Vibration Pad Locations		<b>Series P100 Pressure Control</b> .....	<b>25</b>
<b>Location of Equipment - OUTDOOR</b> .....	<b>5</b>	Figure 13. P100 Pressure Controls	
Ground Mounting		Auto Reset Models	
Roof Mounting		Manual Reset Models	
Unit Vibration Isolation		Liquid Level Switch	
Compressor Spring Vibration Isolators		S-9400 Level Switch Series	
Figure 3. Spring Mount		Table 19. Level Switch Table	
<b>Unit Access</b> .....	<b>6</b>	Figure 14. S-9400	
Vertical Clearance		S-9400 Operation	
Lateral Clearance		<b>Module Replacement</b> .....	<b>26</b>
Decorative Fences		Figure 15. Module Replacement	
Units in Pits		Oil Control	
Multiple Units		Low Pressure Oil System	
<b>Ventilation Requirements</b> .....	<b>7</b>	Figure 16. Low Pressure Oil System	
Electrical		Oil Separators	
Refrigerant Piping		<b>Table 20. AC&amp;R Models</b> .....	<b>27</b>
Suction P-Traps		Temprite Models	
Figure 4. P-Trap requirements		Temprite Valve Adjustment	
Figure 5. P-Trap construction		Table 21. Temprite Models	
<b>Figure 6. Double Suction Risers</b> .....	<b>8</b>	Figure 17. Temprite Oil System	
Figure 7. Inverted Trap		Oil Level Regulators	
Refrigerant Line Insulation		<b>Table 22. AC&amp;R Model Regulators</b> .....	<b>28</b>
Refrigerant Line Support		Troubleshooting Oil System	
Figure 8. Pipe Support		Liquid Filter-Driers & Suction Filters	
<b>Expansion Loops</b> .....	<b>9</b>	Table 23. Sporlan Valve Company	
Figure 9. Offsets		Table 24. Alco Controls	
Table 1. Expansion Chart		<b>Suction Filter</b> .....	<b>29</b>
<b>Table 2. Pressure Loss of Liquid Refrigerants</b> .....	<b>10</b>	Compressor Motor Burnout Clean-up Procedure	
Table 3. Equivalent Feet of Pipe		Sporlan Valve Company	
<b>Table 4. Weight of Refrigerants in Copper Lines During Operation</b> .....	<b>11</b>	<b>Superior Valve Company</b> .....	<b>30</b>
<b>Table 5A. Recommended Line Sizes for R-404A and R-507</b> .....	<b>12</b>	Table 25. Type F Filter	
<b>Table 5B. Recommended Line Sizes for R-404A and R-507 (continued)</b> .....	<b>13</b>	Table 26. Type DF (for clean-up)	
<b>Table 6A. Recommended Line Sizes for R-22</b> .....	<b>14</b>	Alco Controls	
<b>Table 6B. Recommended Line Sizes for R-22 (continued)</b> .....	<b>15</b>	Table 27. Type AF Filter	
<b>Table 7. Recommended Remote Condenser Line Sizes</b> .....	<b>16</b>	Table 28. Type AFD (for clean-up)	
<b>Leak Checking, Evacuation, and Start-up</b> .....	<b>17</b>	Head Pressure Control	
<b>Refrigerant Distribution</b> .....	<b>18</b>	Valve Functions	
Off-Cycle		<b>Liquid Drain Control Method</b> .....	<b>31</b>
Electric Defrost		Recommended Valve Settings	
Priority I Hot Gas Defrost		Table 29. Pressure Range, Set Point & Change per Turn	
Head Pressure Control System		Field Adjustment	
<b>Electronic Control System</b> .....	<b>19</b>	Hot Gas Bypass Regulator Adjustment	
System Balancing		Sporlan Valve Company	
System Superheat (NOTE: Superheat is not preset at factory)		Valve Setting and Adjustment	
Evaporator Superheat		<b>Alco Controls</b> .....	<b>32</b>
Alternative Superheat Method		Valve Setting and Adjustment	
<b>Compressors</b> .....	<b>20</b>	Control Settings	
Copeland Compressors		Table 30. Control settings for R-404A/R-507	
Table 8. 3D/4D/6D Solid State Modules		Table 31. Control settings for R-22	
Table 9. Typical Voltage Ranges		Low Pressure Switch Setting for RMCC	
Table 10. Unloader Factors		<b>General Maintenance Schedule</b> .....	<b>33</b>
<b>Table 11. Oil Safety Switch</b> .....	<b>21</b>	<b>SERVICE DIAGNOSIS CHART</b> .....	<b>34-35</b>
Table 12. Oil Charges		<b>Service Record</b> .....	<b>36</b>
Approved Copeland Lubricants		System Reference Data	
Carlyle Compressors			
Approved Carlyle Lubricants			
Oil Pressure			
Table 13. O6D/E Oil Pressure History			

## Introduction

Parallel Compressor systems are central refrigeration units employing 2 to 8 parallel piped compressors, a control panel, and receiver mounted on one common base frame. The system may be designed for either Indoor or Outdoor use. The Outdoor design may include the condenser mounted and piped.

The selection and design of the system is based on the needs of the individual customer. The most important point in planning an installation of the Heatcraft parallel system is the proper selection of the system components for the particular application.

Component parts have been selected for their dependability and availability to keep service problems to a minimum. Simplicity of design has also made the Heatcraft parallel system one of the easiest to service and install. The simplicity and compactness of the Heatcraft design make the addition of hot gas defrost and/or heat reclaim a simple and economical feature.

In the following pages will be found explanations of system components, wiring and piping diagrams, control settings, and operational guides.

## Inspection

Unit inspection should be assigned to a dependable individual. Inspect the parallel system and any accessories shipped with them for damages or shortages before and during unloading. All items on bill of lading should be accounted for prior to signing the shipping receipt. Note any shortages or damage on carrier's delivery receipt (Specify the extent and type of damage found). Unit should be inspected carefully for concealed damage. Notify the Heatcraft sales representative and the carrier of the damage immediately. Request an immediate joint inspection with the carrier (Do not repair the unit until inspected by carrier's representative). Care should be exercised when uncrating units to prevent damage.

The system is shipped with a holding charge of dry nitrogen. Check to see that pressure is still in the unit upon receipt. Report lack of pressure immediately to the Heatcraft service department.

**NOTE:** Accessory items such as drier cores, mounting pads, modems, etc. may be packaged in a separate carton. Be sure that you receive all items.

## Unit Designation

Units are identified by letter, brand, compressor type, quantity of compressors, horsepower, condenser type, control voltage, defrost type, refrigerant/range, unit voltage and application. Unless otherwise requested by the customer all refrigeration circuits are numbered from one to the highest and from left to right while facing the electrical panel.

## Model Definition:

### 1st digit - Brand (B, C, H, or L)

### 2nd digit - Compressor Type

H - Hermetic  
R - Reciprocating  
S - Screw  
O - Open  
Z - Scroll\*  
C - Compound

### 3rd digit - Unit Construction

R - Remote Condenser  
U - Attached Condenser  
H - Hybrid  
M - Multi-compressor Platform  
F - Frame Hybrid (Frame + Standard Unit)

### 4th digit - Compressor Quantity

2 - 2 Compressors  
3 - 3 Compressors  
4 - 4 Compressors  
Etc.

### 5th, 6th, & 7th digit - Horsepower

030 - 30 HP  
075 - 75 HP  
100 - 100 HP  
Etc.

### 8th digit - Condenser Type

A - Air  
W - Water  
E - Evaporative

### 9th digit - Control Voltage

A - 115/1/60  
B - 208-230/1/60  
C - 24/1/60

### 10th digit - Defrost Type

A - Air/Off-Cycle  
E - Electric  
G - Hot Gas  
M - Multiple  
W - Water

### 11th digit - Temperature Range

L - Low  
M - Medium  
H - High  
C - Combination  
X - Ultra Low

### 12th digit - Refrigerant Type

2 - R-22  
4 - R-134A  
6 - R-404A, R-507  
8 - Multiple

### 13th digit - Unit Voltage

C - 208-230/3/60  
D - 460/3/60  
E - 575/3/60  
J - 208/3/60  
K - 230/3/60  
M - 380/3/60

### 14th digit - Application

1 - Indoor  
2 - Outdoor

## System Warranty

This equipment is designed to operate properly and produce the rated capacity when installed in accordance with good refrigeration practice.

The following conditions should be adhered to when installing this unit to maintain the manufacturers warranty:

- System piping must be in accordance with good refrigeration practices
- Inert gas must be charged into the piping during brazing
- The power supply to the unit must meet the following conditions:
  - All voltages must be +/- 10% of the name plate ratings
  - Phase (voltage) imbalance cannot exceed 2%
- All control and safety switch circuits must be properly connected according to the wiring diagram
- The factory installed wiring must not be changed without written factory approval

## Rigging

**Warning:** Careful considerations for lifting should be made before the unit is lifted by any means. The only part of the unit designed to carry any of the lifting load is the welded channel base. The unit may be lifted at the base with a forklift or by

### Figure 1. Vibration Pad and Spring Isolator

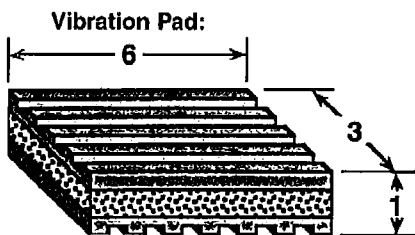

Spring Isolator:



Spring Isolator Dimensions:

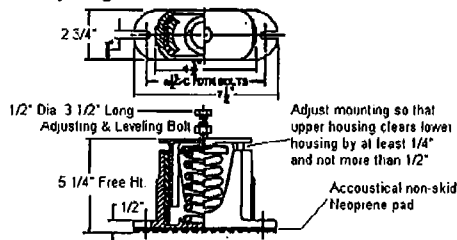

means of cables at the four corners of the base. If cables are used, the lifting cables should be prevented from contacting any of the unit piping or electrical components.

## Location Of Equipment - Indoor

### Clearances

The parallel systems should be located so they are level and easily serviced. The minimum suggested clearance around the units should be 24 inches at the rear and 42 inches in the front of panel (or as required by National or Local Codes). For parallel system units placed end to end, 24 inches between units is suggested.

### Floor & Foundation Requirements

The total weight of a single unit will vary between 1200 pounds and 10,000 pounds. Allowances must be made for the parallel rack and all other equipment installed in the same area as the parallel units. The location and installation of all equipment should be in accordance with all local and national code requirements.

While each unit is constructed with a welded steel base frame adequately designed to withstand vibration, the natural pulsating action of the interconnected motor-compressors may cause considerable noise and vibration if the unit is not mounted on a firm level surface and isolated from the structure of the building.

### Vibration Mounts

In ordinary ground level or basement installations, all that is necessary to assure a vibration-free installation is to place the unit on the concrete floor with the waffle-surfaced resilient pads supplied. See Figure 2 for suggested pad locations. Mezzanine and other installations require some special considerations. The equivalent of 6 inch thick properly reinforced concrete floor must be provided for mounting parallel units above grade. It is recommended that the suggestions previously given for rigid floor construction on above-grade installations be closely adhered to. If this is not possible, special vibration

**NOTE:** Turn each leveling nut until the tip casting rises 1/4" to 3/8" above the bottom casting. MOUNT ADJUSTMENT SHOULD NEVER EXCEED 3/4".

### Figure 2. Vibration Pad Locations

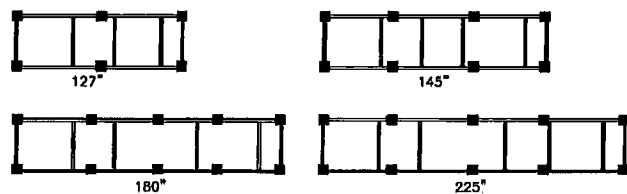

absorbing spring mounts (optional equipment) must be placed under the base frame of each unit. See Figure 1 for view of Spring Isolator. The spring mounts are placed under the unit and the unit carefully lowered on to the mounts. Note that no other mounting hardware is required and any unevenness in the floor or uneven weight distribution may be compensated for by turning the spring mount leveling nuts with an open-end wrench. This adjustment should be made after all piping is installed and the system is charged with refrigerant.

## Location of Equipment - Outdoor

- The mounting platform or base should be level and located so as to permit free access of supply air.
- Units must not be located in the vicinity of steam, hot air or fume exhausts.
- The unit should be mounted away from noise sensitive spaces such as offices.
- The unit must have adequate support to avoid vibration and noise transmission into the building. Sound and structural consultants should be retained for recommendations.

## Ground Mounting

The unit must be set on a flat and level foundation. A single piece concrete slab with footings extending below the frost line and raised approximately six inches above ground level provides a suitable base. Raising the base above ground level provides some protection from ground water and wind blown matter. The concrete slab should be isolated from the building structure. Finally, before tightening mounting bolts, recheck the level of the unit.

## Roof Mounting

Rooftop installations require adequate structural beams to support the weight of the unit and service personnel. The design of the beams/supports must minimize deflection and attendant vibration transmission.

Due to the weights involved, a structural analysis by a qualified engineer may be required before mounting. Also, for sound sensitive applications, unit vibration isolators should be used.

## Unit Vibration Isolation

Under certain critical conditions, it is recommended that vibration isolators, of a suitable type, be installed under the base. The isolators must be designed for the operating weight of the unit. Rubber-in-shear or spring type isolators (by others) are available for this purpose.

## Compressor Spring Vibration Isolators

On units with this option, the compressors are secured rigidly to make sure there is no transit damage. Before operating the unit, it is necessary to follow these steps:

1. Remove the upper nuts and washers
2. Discard the shipping spacers
3. Install the neoprene spacers (Spacers located in the electrical panel or tied to compressor)
4. Replace the upper mounting nuts and washers
5. Allow 1/16 inch space between the mounting nut/washer and the neoprene spacer

**Figure 3. Spring Mount**

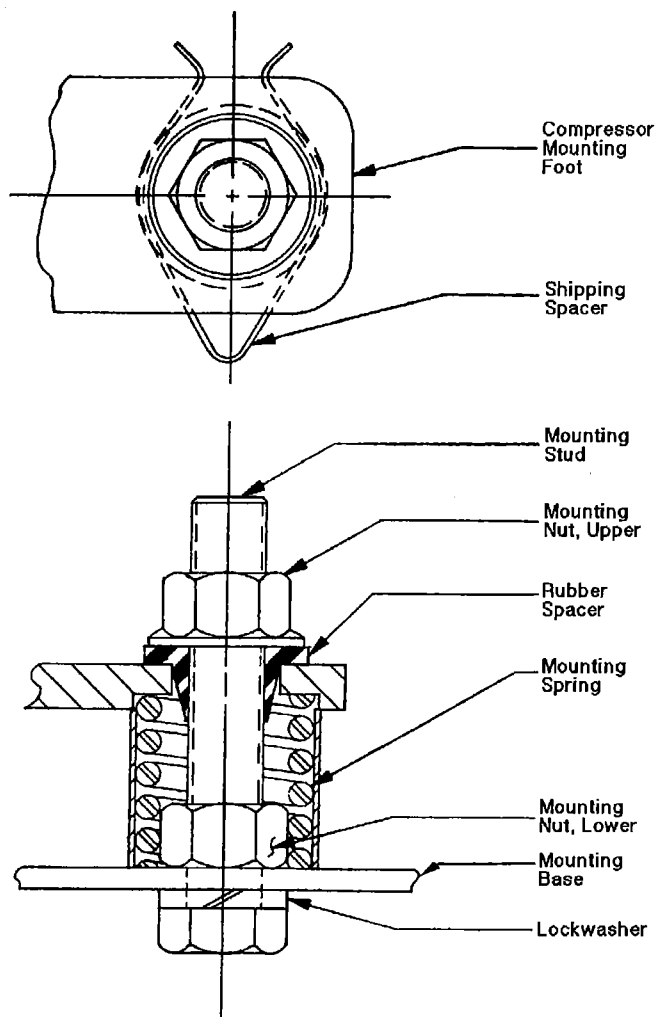

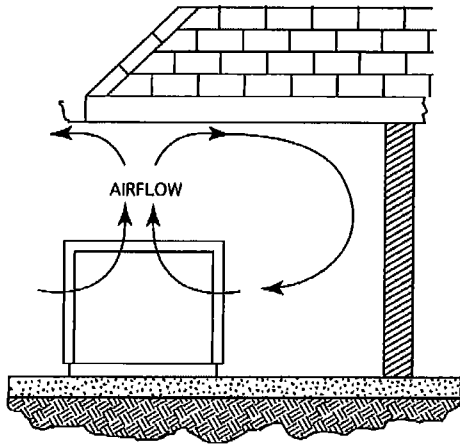

## Unit Access

Always provide sufficient clearance for unit maintenance and service. Minimum clearances for most situations are described below (except 60 Inches of free space is required in front of the control panel). Please note that these are minimums and more clearance may be required by local codes.

## Vertical Clearance

Overhead obstructions are not permitted. Vertical air discharge from the condenser must have no obstructions that can cause the discharge air to be recirculated back to the inlet side of the unit.

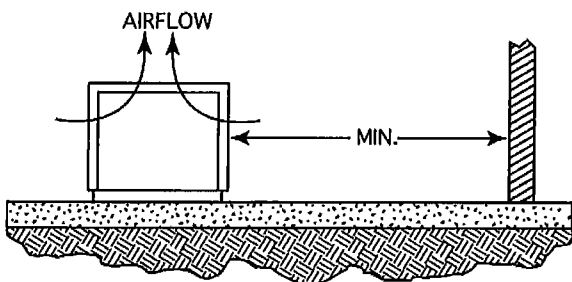

## Lateral Clearance (Walls or Obstructions)

The unit should be located so that air may circulate freely and not be recirculated. For proper air flow and access, all sides of the unit (except control panel end) should be a minimum of four feet (1.2 m) away from any wall or obstruction. It is preferred that this distance be increased whenever possible. Care should be taken to see that ample room is left for maintenance work through access doors and panels. When the unit is in an area where it is enclosed by three walls the unit must be installed under the guidelines for unit installations in pits.

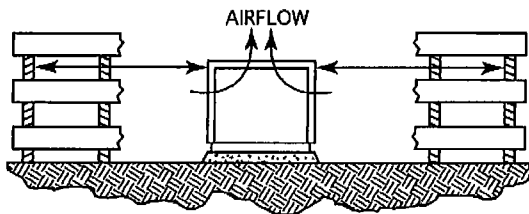

## Decorative Fences

Fences may be installed closer than the four foot (1.2 m) lateral minimum (except on the control panel end) requirement whenever fences permit sufficient free area to allow adequate air flow to the unit. Once again, care should be taken to leave ample room for unit service. Recommended service clearances are listed above.

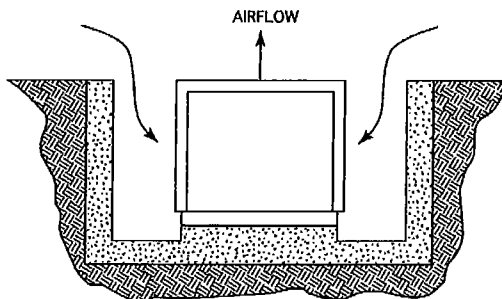

## Units in Pits

The top of the unit should be level with the top of the pit. If the top of the unit is not level with the top of the pit, a wider pit or discharge stacks must be used to raise discharge air to the top of the pit. This is a minimum requirement.

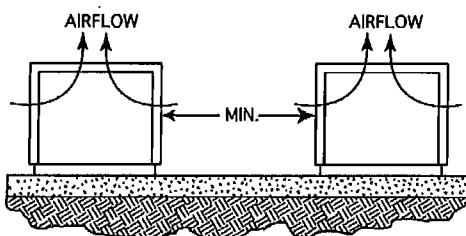

## Multiple Units (Unit-to-Unit Clearance)

For units placed side by side, the minimum distance between units is eight feet (2.4 m) to prevent air recirculation.

## Ventilation Requirements

### Indoor Units

If compressors or condensing units are located in a machine room, adequate ventilation air must be provided to avoid an excessive temperature rise in the room. To allow for peak summer temperatures a 10°F temperature rise is recommended, although a 15°F rise might be acceptable.

With compressors with remote condensers, approximately 10% of the heat rejected is given off by the compressor casting and the discharge tubing. The correct formula for calculating the ventilation requirement of the Indoor Parallel unit is:

$$\text{CFM} = \frac{10\% \text{ of THR} / \text{hr}}{10^\circ \text{TD}}$$

The air intake should be positioned so that air passes over the units. All State, Local, and National codes should be followed.

### Electrical

To insure the proper operation of equipment and reduce the possibility of interruption of refrigeration due to electrical power failure, the following precautions must be observed:

- All electrical work must be done in accordance with the National Electrical Code and existing local codes
- The power supply must be the same as specified on the unit data plate
- An adequate power supply must be provided
- Voltage fluctuations in excess of 10 percent must be corrected
- Overload relays (Carrier compressors only) are selected in accordance with specified limits as determined by the motor-compressor manufacturer. They must not be changed in size or shorted-out
- Control panels must be provided with a single phase, 60 Hertz supply. See the unit wiring diagram for the voltage requirement
- Before starting up a parallel unit, insure that all fuses and motor-protective devices are in place and that all wiring is secure. A complete wiring diagram for troubleshooting the unit will be found inside the control panel cover

### Refrigerant Piping

The system as supplied by Heatcraft, was thoroughly cleaned and dehydrated at the factory. Foreign matter may enter the system by way of the field piping required. Therefore, care must be used during installation of the piping to prevent introduction of foreign matter.

Install all refrigeration system components in accordance with all applicable local and national codes and in conformance with good practice required for the proper operation of the system.

Proper size refrigeration lines are essential to good refrigeration performance. Suction lines are more critical than liquid or

discharge lines. Oversized suction lines may prevent proper oil return to the compressor. Undersized lines can rob refrigeration capacity and increase operating cost. Consult the line sizing charts in this manual for proper pipe sizes.

The following procedures should be followed:

1. Do not leave dehydrated compressors or filter-driers open to the atmosphere
2. Use only refrigeration grade copper tubing, properly sealed against contamination
3. Suction lines should slope 1/4" per 10 feet towards the compressor
4. Discharge lines should slope 1/4" per 20 feet toward the condenser

### Suction P-Traps

- Provide P-Traps at the base of each suction riser of four (4) feet or more to enhance oil return to the compressor. Use a P-Trap for each 20 feet section of riser. See Figure 4 below:

**Figure 4. P-Trap Requirements**

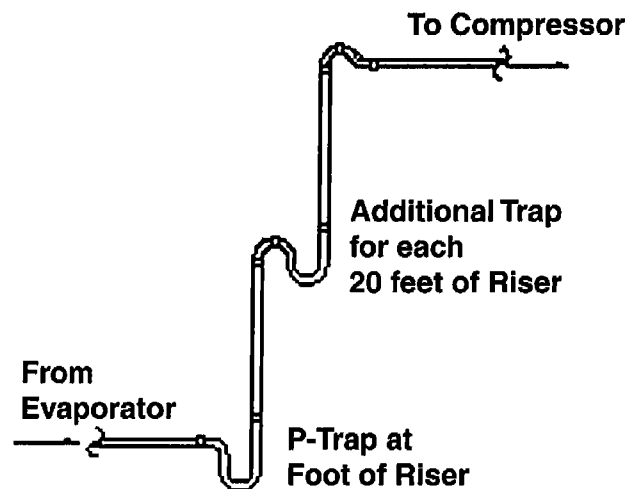

\*The P-Trap should be the same size as the horizontal line  
See Figure 5 below

**Figure 5. P-Trap Construction**

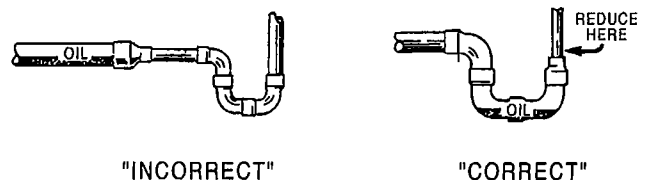

- In systems equipped with capacity control compressors, or where multiple compressors are used with one or more compressors cycled off for capacity control, double suction risers should be installed. See Figure 6 below. The two lines should be sized so that the total cross-section area is equivalent to the cross section area of a single riser that would have both satisfactory gas velocity and acceptable pressure drop at maximum load conditions. The two lines normally are different in size, with the larger line trapped as shown. The smaller line must be sized to provide adequate velocities and acceptable pressure drop when the entire minimum load is carried in the smaller riser.

**Figure 6. Double Suction Risers**

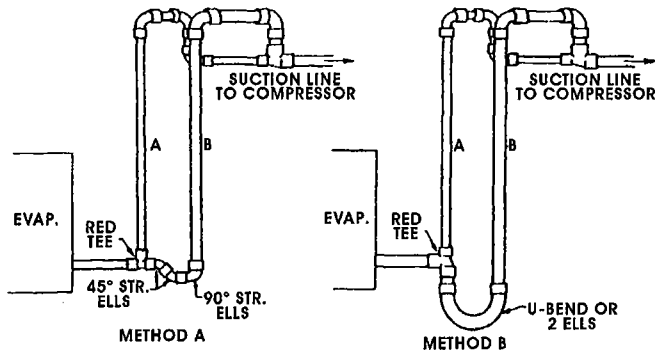

- In operation, at maximum load conditions gas and entrained oil will be flowing through both risers. At minimum load conditions, the gas velocity will not be high enough to carry oil up both risers. The entrained oil will drop out of the refrigerant gas flow and accumulate in the "P" trap forming a liquid seal. This will force all of the flow up the smaller riser, thereby raising the velocity and assuring oil circulation through the system.
- When connecting more than one suction line to a main trunk line, connect each branch line with an inverted trap. See Figure 7 below:

**Figure 7. Inverted Trap**

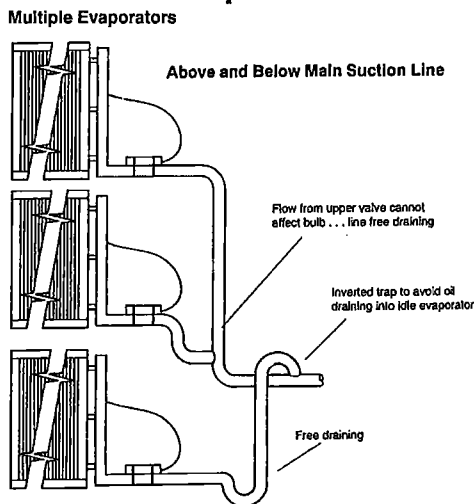

- When brazing refrigerant lines, an inert gas should be passed through the line at low pressure to prevent scaling and oxidation inside the tubing. Dry nitrogen is preferred.
- Use long radius ell's for lower pressure drop.
- Provide expansion loops in long straight refrigerant lines that are subject to expansion and contraction. See Expansion Loops in this manual for more information.

## Refrigerant Line Insulation

- Insulate suction lines from the evaporators to the parallel unit with minimum 3/4" thickness closed-cell type insulation on low temperature circuits. Insulate suction lines on medium temperature circuits with minimum 1/2" thick insulation to prevent condensation.
- Long liquid lines run in areas exposed to high temperatures should be fully insulated with minimum 1/2" insulation.
- Suction and liquid lines should never be taped or soldered together.

## Refrigerant Line Support

- Strap and support tubing to prevent excessive line vibration and noise. All tubing clamps should have an insulating material (i.e. Hydra Sorb bushing) to prevent metal to metal contact.

**Figure 8. Pipe Support**

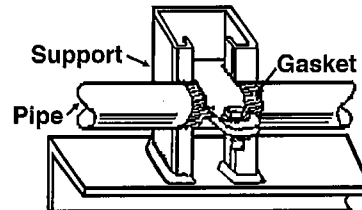

- Straight runs should be supported near each end.
- Long runs require additional supports.
- A general guide is:
  - 3/8" to 7/8" every 5 feet
  - 1-1/8" to 1-3/8" every 7 feet
  - 1-5/8" to 2-1/8" every 10 feet
- When changing directions, supports should be placed a maximum of 2 feet in each direction.
- Piping attached to a vibrating object (such as a compressor or compressor base) must be supported in such a manner that will not restrict the movement of the vibrating object. Rigid mounting will fatigue the copper tubing.
- Use only a suitable silver solder alloy on suction and liquid lines.
- Limit the soldering paste or flux to the minimum required to prevent contamination of the solder joint internally. Flux only the male portion of the connection, never the female. After brazing, remove excess flux.



## Expansion Loops

Suction, liquid and remote condenser lines are subject to expansion and contraction and proper piping techniques must be employed (especially on hot gas lines) to prevent line breakage. This is critical on long straight runs of generally 70' or more where expansion loops must be provided and hangers should allow for longitudinal movement of the piping.

On a refrigeration system with gas defrost, the refrigerant lines expand and contract with temperature changes. The suction line normally has the greatest movement since it has the largest temperature change during defrost. If the expansion and contraction is not planned for during the installation of refrigeration lines, kinking and breaking of the lines could occur.

In order to compensate for the expansion of the tubing, it is necessary to estimate the amount of expansion and then provide offsets or loops in the refrigerant piping. Normally the area to be most concerned with is the straight line distance from the fixture to the parallel compressor unit.

A simple form of expansion loop can be made of soft tempered copper tube by bending it to the correct size and shape. A neater type is made by assembling hard tube with solder elbows as in Figure 9. The correct proportions of such expansion loops to meet various conditions are shown in Table 1.

In compensating for expansion and contraction, two items are very important:

- Liquid and suction lines can not be joined together and should not touch at any point
- Pipe hangers must be located and installed in such a manner as not to restrict the expansion and contraction of the tubing. All tubing clamps should have an insulating material (i.e. Hydra Sorb bushing) to prevent metal to metal contact

**Figure 9. Offsets**

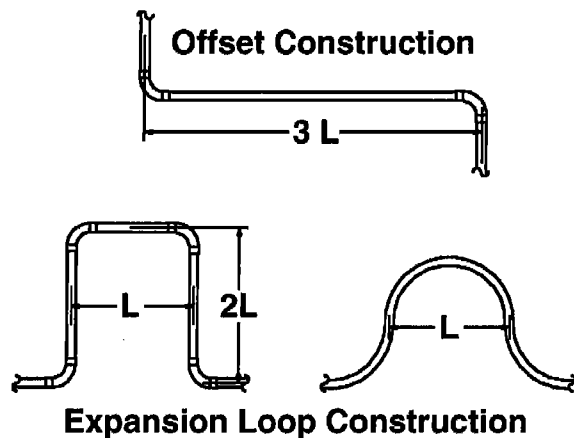

**Table 1. Expansion Chart**

Table of Values for "L"

Ref. Line OD (in.)	Amount of Expansion (in.)								
	1/2	1	1-1/2	2	2-1/2	3	4	5	6
7/8	10	15	19	22	25	27	30	34	38
1-1/8	11	16	20	24	27	29	33	38	42
1-3/8	11	17	21	26	29	32	36	42	47
1-5/8	12	18	23	28	31	35	39	46	51
2-1/8	14	20	25	31	34	38	44	51	57
2-5/8	16	22	27	32	37	42	47	56	62

**NOTES:** Calculations for expansion and contraction should be based on the average coefficient of expansion of copper which is .0000094 per degree Fahrenheit between 77°F and 212°F. Example, the expansion for each 100 feet of length of any size of tube heated from room temperature of 70°F to 170°F, a rise of 100°F, is:

$$100^{\circ}\text{F (rise }^{\circ}\text{F)} \times 100 \text{ (linear feet)} \times 12 \text{ (inches)} \times 0.0000094 \text{ (coefficient)} = 1.128 \text{ inches}$$

(Reprinted from Copper & Brass Research Association)

**Table 2. Pressure Loss of Liquid Refrigerants**  
(In Liquid Line Risers - Expressed in Pressure Drop, PSIG, and Subcooling Loss, °F)

Refrigerant	Liquid Line Rise in Feet																	
	10'		15'		20'		25'		30'		40'		50'		75'		100'	
	PSIG	°F	PSIG	°F	PSIG	°F	PSIG	°F	PSIG	°F	PSIG	°F	PSIG	°F	PSIG	°F	PSIG	°F
<b>R-12</b>	5.4	2.8	8.1	4.2	10.7	5.4	13.4	6.9	16.1	8.3	21.5	11.3	26.9	14.3	40.3	22.4	53.7	31.0
<b>R-22</b>	4.8	1.6	7.3	2.3	9.7	3.1	12.1	3.8	14.5	4.7	19.4	6.2	24.2	8.0	36.3	12.1	48.4	16.5
<b>R-502</b>	4.9	1.5	7.3	2.2	9.7	3.0	12.1	3.7	14.6	4.5	19.5	6.0	24.3	7.6	36.4	11.5	48.6	14.8
<b>R-134A</b>	4.9	2.0	7.4	2.9	9.8	4.1	12.3	5.2	14.7	6.3	19.7	8.8	24.6	11.0	36.8	17.0	49.1	23.7
<b>R-404A/R-507</b>	4.1	1.1	6.1	1.6	8.2	2.1	10.2	2.7	12.2	3.3	16.3	4.1	20.4	5.6	30.6	8.3	40.8	11.8

Based on 110°F liquid temperature at bottom of riser

**Table 3. Equivalent Feet of Pipe**  
(Due to Valve and Fitting Friction)

Copper Tube OD, Type "L"	1/2	5/8	7/8	1-1/8	1-3/8	1-5/8	2-1/8	2-5/8	3-1/8	3-5/8	4-1/8	5-1/8	6-1/8
Globe Valve (Open)	14	16	22	28	36	42	57	69	83	99	118	138	168
Angle Valve (Open)	7	9	12	15	18	21	28	34	42	49	57	70	83
90° Turn Through Tee	3	4	5	6	8	9	12	14	17	20	22	28	34
Tee - Straight Through or Sweep Below	.75	1	1.5	2	2.5	3	3.5	4	5	6	7	9	11
90° Elbow or Reducing Tee (Straight Through)	1	2	2	3	4	4	5	7	8	10	12	14	16

**Table 4. Weight of Refrigerants in Copper Lines During Operation**  
(Pounds per 100 Lineal Feet of Type "L" Tubing)

Line Size OD (in.)	Refrigerant	Liquid Line	Hot Gas Line	Suction Line at Suction Temperature				
				-40°F	-20°F	0°F	20°F	40°F
3/8	12, 134A	4.0	.15	.01	.01	.02	.04	.06
	22	3.9	.22	.02	.03	.04	.06	.08
	R-507, 502, 404A	3.4	.31	.03	.04	.06	.09	.13
1/2	12, 134A	7.4	.30	.01	.03	.04	.07	.11
	22	7.4	.41	.03	.05	.07	.11	.15
	R-507, 502, 404A	6.4	.58	.04	.07	.13	.16	.24
5/8	12, 134A	11.9	.47	.02	.05	.07	.12	.17
	22	11.8	.65	.05	.08	.12	.17	.25
	R-507, 502, 404A	10.3	.93	.07	.11	.17	.25	.35
7/8	12, 134A	24.7	.99	.05	.10	.15	.24	.36
	22	24.4	1.35	.10	.16	.24	.36	.51
	R-507, 502, 404A	21.2	1.92	.15	.23	.37	.51	.72
1-1/8	12, 134A	42.2	1.70	.08	.17	.26	.41	.60
	22	41.6	2.30	.17	.28	.42	.61	.87
	R-507, 502, 404A	36.1	3.27	.26	.39	.63	.86	1.24
1-3/8	12, 134A	64.2	2.57	.14	.26	.40	.61	1.91
	22	63.5	3.50	.27	.42	.64	.93	1.33
	R-507, 502, 404A	55.0	4.98	.40	.58	.95	1.32	1.87
1-5/8	12, 134A	90.9	3.65	.20	.37	.57	.87	1.30
	22	90.0	4.96	.37	.59	.90	1.33	1.88
	R-507, 502, 404A	78.0	7.07	.56	.82	1.35	1.86	2.64
2-1/8	12, 134A	158	6.34	.34	.64	.98	1.51	2.24
	22	156	8.61	.65	1.03	1.57	2.30	3.26
	R-507, 502, 404A	134	12.25	.98	1.43	2.35	3.23	4.58
2-5/8	12, 134A	244	9.78	.52	.99	1.51	2.32	3.47
	22	241	13.70	1.01	1.59	2.42	3.54	5.03
	R-507, 502, 404A	209	18.92	1.51	2.21	3.62	5.00	7.07
3-1/8	12, 134A	348	13.97	.75	1.41	2.16	3.31	4.96
	22	344	18.95	1.44	2.28	3.45	5.05	7.18
	R-507, 502, 404A	298	27.05	2.16	3.15	5.17	7.14	9.95
3-5/8	12, 134A	471	18.90	.99	1.91	2.92	4.48	6.69
	22	465	25.60	1.94	3.08	4.67	6.83	9.74
	R-507, 502, 404A	403	36.50	2.92	4.25	6.97	19.65	13.67
4-1/8	12, 134A	612	24.56	1.29	2.49	3.81	5.84	8.75
	22	605	33.40	2.53	4.01	6.08	8.90	12.70
	R-507, 502, 404A	526	47.57	3.80	5.55	9.09	12.58	17.80

### Table 5A. Recommended Line Sizes for R-404A/R-507\*

System Capacity BTU/H	Suction Line Size																				
	Suction Temperature																				
	20°F						10°F						-10°F						-20°F		
	Equivalent Lengths						Equivalent Lengths						Equivalent Lengths						Equivalent		
	25'	50'	75'	100'	150'	200'	25'	50'	75'	100'	150'	200'	25'	50'	75'	100'	150'	200'	25'	50'	75'
1,000	3/8	3/8	3/8	3/8	3/8	3/8	3/8	3/8	3/8	3/8	3/8	1/2	3/8	3/8	3/8	1/2	1/2	1/2	3/8	3/8	1/2
3,000	3/8	3/8	1/2	1/2	1/2	5/8	3/8	1/2	1/2	1/2	5/8	5/8	1/2	1/2	5/8	5/8	5/8	7/8	1/2	1/2	5/8
4,000	3/8	1/2	1/2	1/2	5/8	5/8	1/2	1/2	1/2	5/8	5/8	7/8	1/2	5/8	5/8	5/8	7/8	7/8	1/2	5/8	5/8
6,000	1/2	1/2	5/8	5/8	7/8	7/8	1/2	1/2	5/8	5/8	7/8	7/8	1/2	5/8	5/8	7/8	7/8	7/8	5/8	5/8	7/8
9,000	5/8	5/8	7/8	7/8	7/8	7/8	5/8	5/8	7/8	7/8	7/8	7/8	5/8	7/8	7/8	7/8	7/8	1-1/8	5/8	7/8	7/8
12,000	5/8	7/8	7/8	7/8	7/8	7/8	5/8	7/8	7/8	7/8	7/8	1-1/8	7/8	7/8	7/8	7/8	1-1/8	1-1/8	7/8	7/8	7/8
15,000	5/8	7/8	7/8	7/8	7/8	1-1/8	7/8	7/8	7/8	7/8	1-1/8	1-1/8	7/8	7/8	7/8	1-1/8	1-1/8	1-1/8	7/8	7/8	1-1/8
18,000	7/8	7/8	7/8	7/8	1-1/8	1-1/8	7/8	7/8	7/8	1-1/8	1-1/8	1-1/8	7/8	7/8	1-1/8	1-1/8	1-1/8	1-3/8	7/8	1-1/8	1-1/8
24,000	7/8	7/8	7/8	1-1/8	1-1/8	1-1/8	7/8	1-1/8	1-1/8	1-1/8	1-1/8	1-3/8	7/8	1-1/8	1-1/8	1-3/8	1-3/8	1-3/8	1-1/8	1-1/8	1-1/8
30,000	7/8	7/8	1-1/8	1-1/8	1-1/8	1-3/8	7/8	1-1/8	1-1/8	1-1/8	1-3/8	1-3/8	1-1/8	1-1/8	1-1/8	1-3/8	1-3/8	1-3/8	1-1/8	1-1/8	1-1/8
36,000	7/8	1-1/8	1-1/8	1-1/8	1-3/8	1-3/8	1-1/8	1-1/8	1-1/8	1-3/8	1-3/8	1-3/8	1-1/8	1-1/8	1-3/8	1-3/8	1-3/8	1-5/8	1-1/8	1-1/8	1-3/8
42,000	1-1/8	1-1/8	1-1/8	1-3/8	1-3/8	1-3/8	1-1/8	1-1/8	1-3/8	1-3/8	1-3/8	1-5/8	1-1/8	1-3/8	1-3/8	1-3/8	1-5/8	1-5/8	1-1/8	1-3/8	1-3/8
48,000	1-1/8	1-1/8	1-3/8	1-3/8	1-3/8	1-3/8	1-1/8	1-1/8	1-3/8	1-3/8	1-5/8	1-5/8	1-1/8	1-3/8	1-3/8	1-3/8	1-5/8	1-5/8	1-1/8	1-3/8	1-3/8
54,000	1-1/8	1-1/8	1-3/8	1-3/8	1-3/8	1-5/8	1-1/8	1-3/8	1-3/8	1-3/8	1-5/8	1-5/8	1-3/8	1-3/8	1-3/8	1-5/8	1-5/8	1-5/8	1-3/8	1-3/8	1-5/8
60,000	1-1/8	1-1/8	1-3/8	1-3/8	1-5/8	1-5/8	1-1/8	1-3/8	1-3/8	1-5/8	1-5/8	1-5/8	1-3/8	1-3/8	1-5/8	1-5/8	1-5/8	2-1/8	1-3/8	1-3/8	1-5/8
66,000	1-1/8	1-3/8	1-3/8	1-3/8	1-5/8	1-5/8	1-1/8	1-3/8	1-3/8	1-5/8	1-5/8	1-5/8	1-3/8	1-5/8	1-5/8	1-5/8	1-5/8	1-5/8	1-3/8	1-5/8	1-5/8
72,000	1-1/8	1-3/8	1-3/8	1-5/8	1-5/8	1-5/8	1-1/8	1-3/8	1-5/8	1-5/8	1-5/8	1-5/8	1-3/8	1-5/8	1-5/8	1-5/8	1-5/8	1-5/8	1-3/8	1-5/8	1-5/8
78,000	1-1/8	1-3/8	1-3/8	1-5/8	1-5/8	2-1/8	1-3/8	1-3/8	1-5/8	1-5/8	1-5/8	2-1/8	1-3/8	1-5/8	1-5/8	1-5/8	1-5/8	2-1/8	1-5/8	1-5/8	1-5/8
84,000	1-1/8	1-3/8	1-5/8	1-5/8	1-5/8	2-1/8	1-3/8	1-3/8	1-5/8	1-5/8	2-1/8	2-1/8	1-3/8	1-5/8	1-5/8	1-5/8	2-1/8	2-1/8	1-5/8	1-5/8	1-5/8
90,000	1-3/8	1-3/8	1-5/8	1-5/8	2-1/8	2-1/8	1-3/8	1-5/8	1-5/8	1-5/8	2-1/8	2-1/8	1-5/8	1-5/8	1-5/8	2-1/8	2-1/8	2-5/8	1-5/8	1-5/8	2-1/8
120,000	1-3/8	1-5/8	1-5/8	2-1/8	2-1/8	2-1/8	1-3/8	1-5/8	2-1/8	2-1/8	2-1/8	2-1/8	1-5/8	2-1/8	2-1/8	2-1/8	2-5/8	2-5/8	1-5/8	2-1/8	2-1/8
150,000	1-5/8	1-5/8	2-1/8	2-1/8	2-1/8	2-1/8	1-5/8	2-1/8	2-1/8	2-1/8	2-5/8	2-5/8	2-1/8	2-1/8	2-1/8	2-5/8	2-5/8	2-5/8	2-1/8	2-1/8	2-1/8
180,000	1-5/8	2-1/8	2-1/8	2-1/8	2-1/8	2-5/8	1-5/8	2-1/8	2-1/8	2-1/8	2-5/8	2-5/8	2-1/8	2-1/8	2-5/8	2-5/8	2-5/8	3-1/8	2-1/8	2-1/8	2-5/8
210,000	1-5/8	2-1/8	2-1/8	2-1/8	2-5/8	2-5/8	2-1/8	2-1/8	2-1/8	2-5/8	2-5/8	2-5/8	2-1/8	2-1/8	2-5/8	2-5/8	3-1/8	3-1/8	2-1/8	2-5/8	2-5/8
240,000	1-5/8	2-1/8	2-1/8	2-1/8	2-5/8	2-5/8	2-1/8	2-1/8	2-5/8	2-5/8	2-5/8	2-5/8	2-1/8	2-5/8	2-5/8	2-5/8	3-1/8	3-1/8	2-1/8	2-5/8	2-5/8
300,000	2-1/8	2-1/8	2-5/8	2-5/8	2-5/8	3-1/8	2-1/8	2-5/8	2-5/8	2-5/8	3-1/8	3-1/8	2-5/8	2-5/8	2-5/8	3-1/8	3-1/8	3-5/8	2-5/8	2-5/8	2-5/8
360,000	2-1/8	2-1/8	2-5/8	2-5/8	3-1/8	3-1/8	2-1/8	2-5/8	2-5/8	2-5/8	3-1/8	3-1/8	2-5/8	2-5/8	3-1/8	3-1/8	3-5/8	3-5/8	2-5/8	2-5/8	3-1/8
480,000	2-1/8	2-5/8	2-5/8	3-1/8	3-1/8	3-5/8	2-5/8	2-5/8	2-5/8	2-5/8	3-5/8	3-5/8	2-5/8	3-1/8	3-1/8	3-5/8	3-5/8	4-1/8	2-5/8	3-1/8	3-1/8
600,000	2-5/8	2-5/8	3-1/8	3-1/8	3-5/8	3-5/8	2-5/8	2-5/8	3-1/8	3-1/8	3-5/8	3-5/8	3-1/8	3-1/8	3-1/8	3-5/8	4-1/8	4-1/8	3-1/8	3-1/8	3-1/8
720,000	2-5/8	3-1/8	3-1/8	3-5/8	3-5/8	4-1/8	3-1/8	3-1/8	3-5/8	3-5/8	4-1/8	4-1/8	3-5/8	3-5/8	4-1/8	5-1/8	5-1/8	5-1/8	3-5/8	4-1/8	5-1/8
900,000	3-1/8	3-1/8	3-5/8	3-5/8	4-1/8	4-1/8	3-1/8	3-5/8	3-5/8	4-1/8	5-1/8	5-1/8	3-5/8	4-1/8	5-1/8	5-1/8	5-1/8	5-1/8	4-1/8	5-1/8	5-1/8

**\* NOTES:**

- Sizes that are highlighted indicate maximum suction line sizes that should be used for risers. Riser size should not exceed horizontal size. Properly placed suction traps must also be used for adequate oil return. All sizes shown are for OD Type L copper tubing
- Suction line sizes selected at pressure drop equivalent to 2°F. Reduce estimate of system capacity accordingly
- Recommended liquid line size may increase with reverse cycle hot gas systems
- If system load drops below 40% of design, consideration to installing double suction risers should be made

**Table 5B. Recommended Line Sizes for R-404A/R-507 (continued)\***

Suction Line Size															Liquid Line Size						System Capacity BTU/H
Suction Temperature															Receiver to Expansion Valve Equivalent Lengths						
-20°F Lengths			-30°F Equivalent Lengths						-40°F Equivalent Lengths												
100'	150'	200'	25'	50'	75'	100'	150'	200'	25'	50'	75'	100'	150'	200'	25'	50'	75'	100'	150'	200'	
1/2	1/2	1/2	3/8	3/8	1/2	1/2	1/2	5/8	3/8	1/2	1/2	1/2	5/8	5/8	3/8	3/8	3/8	3/8	3/8	3/8	1,000
5/8	7/8	7/8	1/2	1/2	5/8	5/8	7/8	7/8	1/2	1/2	5/8	5/8	7/8	7/8	3/8	3/8	3/8	3/8	3/8	3/8	3,000
7/8	7/8	7/8	5/8	5/8	5/8	7/8	7/8	7/8	1/2	5/8	5/8	7/8	7/8	7/8	3/8	3/8	3/8	3/8	3/8	3/8	4,000
7/8	7/8	7/8	5/8	5/8	7/8	7/8	7/8	7/8	5/8	5/8	7/8	7/8	7/8	1-1/8	3/8	3/8	3/8	3/8	3/8	3/8	6,000
7/8	1-1/8	1-1/8	5/8	7/8	7/8	7/8	1-1/8	1-1/8	5/8	7/8	7/8	7/8	1-1/8	1-1/8	3/8	3/8	3/8	3/8	3/8	3/8	9,000
1-1/8	1-1/8	1-1/8	7/8	7/8	7/8	1-1/8	1-1/8	1-1/8	7/8	7/8	7/8	1-1/8	1-1/8	1-1/8	3/8	3/8	3/8	3/8	3/8	1/2	12,000
1-1/8	1-1/8	1-3/8	7/8	7/8	1-1/8	1-1/8	1-1/8	1-3/8	7/8	7/8	1-1/8	1-1/8	1-1/8	1-3/8	3/8	3/8	3/8	3/8	1/2	1/2	15,000
1-1/8	1-3/8	1-3/8	7/8	1-1/8	1-1/8	1-1/8	1-3/8	1-3/8	7/8	1-1/8	1-1/8	1-1/8	1-1/8	1-3/8	3/8	3/8	3/8	1/2	1/2	1/2	18,000
1-3/8	1-3/8	1-3/8	1-1/8	1-1/8	1-1/8	1-3/8	1-3/8	1-3/8	1-1/8	1-1/8	1-1/8	1-3/8	1-3/8	1-3/8	3/8	3/8	1/2	1/2	1/2	1/2	24,000
1-3/8	1-3/8	1-5/8	1-1/8	1-1/8	1-3/8	1-3/8	1-3/8	1-5/8	1-1/8	1-1/8	1-3/8	1-3/8	1-3/8	1-5/8	3/8	1/2	1/2	1/2	1/2	1/2	30,000
1-3/8	1-3/8	1-5/8	1-1/8	1-3/8	1-3/8	1-3/8	1-3/8	1-5/8	1-1/8	1-3/8	1-3/8	1-3/8	1-5/8	1-5/8	1/2	1/2	1/2	1/2	1/2	5/8	36,000
1-5/8	1-5/8	1-5/8	1-1/8	1-3/8	1-3/8	1-3/8	1-5/8	1-5/8	1-1/8	1-3/8	1-3/8	1-3/8	1-5/8	1-5/8	1/2	1/2	1/2	1/2	5/8	5/8	42,000
1-5/8	1-5/8	1-5/8	1-1/8	1-3/8	1-3/8	1-3/8	1-5/8	1-5/8	1-1/8	1-3/8	1-3/8	1-3/8	1-5/8	1-5/8	1/2	1/2	1/2	5/8	5/8	5/8	48,000
1-5/8	1-5/8	1-5/8	1-3/8	1-3/8	1-3/8	1-5/8	1-5/8	2-1/8	1-3/8	1-3/8	1-3/8	1-5/8	1-5/8	2-1/8	1/2	1/2	1/2	5/8	5/8	5/8	54,000
1-5/8	1-5/8	2-1/8	1-3/8	1-3/8	1-5/8	1-5/8	1-5/8	2-1/8	1-3/8	1-3/8	1-5/8	1-5/8	1-5/8	2-1/8	1/2	1/2	5/8	5/8	5/8	5/8	60,000
1-5/8	1-5/8	2-1/8	1-3/8	1-5/8	1-5/8	1-5/8	1-5/8	2-1/8	1-3/8	1-5/8	1-5/8	1-5/8	1-5/8	2-1/8	1/2	1/2	5/8	5/8	5/8	5/8	66,000
1-5/8	1-5/8	2-1/8	1-3/8	1-5/8	1-5/8	1-5/8	1-5/8	2-1/8	1-3/8	1-5/8	1-5/8	1-5/8	1-5/8	2-1/8	1/2	5/8	5/8	5/8	5/8	5/8	72,000
1-5/8	2-1/8	2-1/8	1-5/8	1-5/8	1-5/8	1-5/8	2-1/8	2-1/8	1-5/8	1-5/8	1-5/8	1-5/8	2-1/8	2-1/8	5/8	5/8	5/8	5/8	5/8	7/8	78,000
2-1/8	2-1/8	2-1/8	1-5/8	1-5/8	1-5/8	2-1/8	2-1/8	2-1/8	1-5/8	1-5/8	1-5/8	2-1/8	2-1/8	2-1/8	5/8	5/8	5/8	5/8	7/8	7/8	84,000
2-1/8	2-1/8	2-5/8	1-5/8	2-1/8	2-1/8	2-1/8	2-1/8	2-5/8	1-5/8	1-5/8	2-1/8	2-1/8	2-1/8	2-5/8	5/8	5/8	5/8	7/8	7/8	7/8	90,000
2-1/8	2-5/8	2-5/8	1-5/8	2-1/8	2-1/8	2-1/8	2-5/8	2-5/8	1-5/8	2-1/8	2-1/8	2-1/8	2-5/8	2-5/8	5/8	5/8	7/8	7/8	7/8	7/8	120,000
2-5/8	2-5/8	2-5/8	2-1/8	2-1/8	2-1/8	2-5/8	2-5/8	2-5/8	2-1/8	2-1/8	2-5/8	2-5/8	2-5/8	2-5/8	5/8	7/8	7/8	7/8	7/8	1-1/8	150,000
2-5/8	2-5/8	3-1/8	2-1/8	2-1/8	2-5/8	2-5/8	2-5/8	3-1/8	2-1/8	2-1/8	2-5/8	2-5/8	2-5/8	3-1/8	7/8	7/8	7/8	7/8	1-1/8	1-1/8	180,000
2-5/8	3-1/8	3-1/8	2-1/8	2-5/8	2-5/8	2-5/8	3-1/8	3-1/8	2-1/8	2-5/8	2-5/8	2-5/8	3-1/8	3-1/8	7/8	7/8	7/8	1-1/8	1-1/8	1-1/8	210,000
2-5/8	3-1/8	3-1/8	2-5/8	2-5/8	2-5/8	3-1/8	3-1/8	3-5/8	2-5/8	2-5/8	2-5/8	3-1/8	3-1/8	3-5/8	7/8	7/8	1-1/8	1-1/8	1-1/8	1-3/8	240,000
3-1/8	3-5/8	3-5/8	2-5/8	2-5/8	3-1/8	3-1/8	3-5/8	4-1/8	2-5/8	2-5/8	3-1/8	3-5/8	3-5/8	4-1/8	7/8	1-1/8	1-1/8	1-1/8	1-3/8	1-3/8	300,000
3-5/8	3-5/8	4-1/8	2-5/8	3-1/8	3-1/8	3-5/8	3-5/8	4-1/8	2-5/8	3-1/8	3-5/8	3-5/8	4-1/8	4-1/8	1-1/8	1-1/8	1-1/8	1-3/8	1-3/8	1-5/8	360,000
3-5/8	3-5/8	4-1/8	3-1/8	3-5/8	3-5/8	4-1/8	4-1/8	4-1/8	3-1/8	3-5/8	3-5/8	4-1/8	4-1/8	4-1/8	1-1/8	1-1/8	1-3/8	1-3/8	1-5/8	1-5/8	480,000
3-5/8	3-5/8	4-1/8	3-1/8	3-5/8	3-5/8	4-1/8	4-1/8	5-1/8	3-1/8	3-5/8	3-5/8	4-1/8	4-1/8	5-1/8	1-1/8	1-3/8	1-3/8	1-5/8	1-5/8	1-5/8	600,000
5-1/8	5-1/8	5-1/8	4-1/8	5-1/8	5-1/8	5-1/8	5-1/8	6-1/8	4-1/8	5-1/8	5-1/8	5-1/8	5-1/8	6-1/8	1-1/8	1-3/8	1-3/8	1-5/8	1-5/8	2-1/8	720,000
5-1/8	5-1/8	5-1/8	4-1/8	5-1/8	5-1/8	5-1/8	5-1/8	6-1/8	5-1/8	5-1/8	5-1/8	5-1/8	5-1/8	6-1/8	1-3/8	1-3/8	1-5/8	2-1/8	2-1/8	2-1/8	900,000

**\* NOTES:**

- Sizes that are highlighted indicate maximum suction line sizes that should be used for risers. Riser size should not exceed horizontal size. Properly placed suction traps must also be used for adequate oil return. All sizes shown are for OD Type L copper tubing
- Suction line sizes selected at pressure drop equivalent to 2°F. Reduce estimate of system capacity accordingly
- Recommended liquid line size may increase with reverse cycle hot gas systems
- If system load drops below 40% of design, consideration to installing double suction risers should be made

**Table 6A. Recommended Line Sizes for R-22\***

System Capacity BTU/H	Suction Line Size																					
	Suction Temperature																					
	40°F						20°F						10°F						0°F			
	Equivalent Lengths						Equivalent Lengths						Equivalent Lengths						Equivalent			
	25'	50'	75'	100'	150'	200'	25'	50'	75'	100'	150'	200'	25'	50'	75'	100'	150'	200'	25'	50'	75'	
1,000	3/8	3/8	3/8	3/8	3/8	3/8	3/8	3/8	3/8	3/8	3/8	3/8	3/8	3/8	3/8	3/8	3/8	3/8	1/2	3/8	3/8	3/8
3,000	3/8	3/8	3/8	1/2	1/2	1/2	3/8	1/2	1/2	1/2	5/8	5/8	3/8	1/2	1/2	1/2	5/8	5/8	1/2	1/2	1/2	
4,000	3/8	3/8	1/2	1/2	1/2	1/2	3/8	1/2	1/2	1/2	5/8	5/8	1/2	1/2	1/2	5/8	5/8	5/8	1/2	1/2	5/8	
6,000	1/2	1/2	1/2	5/8	5/8	5/8	1/2	1/2	5/8	5/8	5/8	5/8	1/2	5/8	5/8	5/8	7/8	7/8	5/8	5/8	5/8	
9,000	1/2	5/8	5/8	5/8	7/8	7/8	1/2	5/8	5/8	5/8	7/8	7/8	5/8	5/8	7/8	7/8	7/8	7/8	5/8	7/8	7/8	
12,000	5/8	5/8	5/8	7/8	7/8	7/8	5/8	5/8	7/8	7/8	7/8	7/8	5/8	7/8	7/8	7/8	7/8	7/8	5/8	7/8	7/8	
15,000	5/8	5/8	7/8	7/8	7/8	7/8	5/8	7/8	7/8	7/8	7/8	7/8	7/8	7/8	7/8	7/8	1-1/8	1-1/8	7/8	7/8	7/8	
18,000	5/8	7/8	7/8	7/8	7/8	1-1/8	5/8	7/8	7/8	7/8	7/8	1-1/8	7/8	7/8	7/8	7/8	1-1/8	1-1/8	7/8	7/8	1-1/8	
24,000	5/8	7/8	7/8	7/8	1-1/8	1-1/8	7/8	7/8	7/8	7/8	1-1/8	1-1/8	7/8	7/8	1-1/8	1-1/8	1-1/8	1-1/8	7/8	1-1/8	1-1/8	
30,000	7/8	7/8	7/8	1-1/8	1-1/8	1-1/8	7/8	7/8	7/8	1-1/8	1-1/8	1-1/8	7/8	1-1/8	1-1/8	1-1/8	1-1/8	1-1/8	1-3/8	7/8	1-1/8	1-1/8
36,000	7/8	1-1/8	1-1/8	1-1/8	1-1/8	1-3/8	7/8	1-1/8	1-1/8	1-1/8	1-1/8	1-3/8	7/8	1-1/8	1-1/8	1-1/8	1-3/8	1-3/8	1-1/8	1-1/8	1-1/8	
42,000	7/8	1-1/8	1-1/8	1-1/8	1-1/8	1-3/8	7/8	1-1/8	1-1/8	1-1/8	1-3/8	1-3/8	1-1/8	1-1/8	1-1/8	1-3/8	1-3/8	1-3/8	1-1/8	1-1/8	1-3/8	
48,000	7/8	1-1/8	1-1/8	1-1/8	1-1/8	1-3/8	7/8	1-1/8	1-1/8	1-1/8	1-3/8	1-3/8	1-1/8	1-1/8	1-3/8	1-3/8	1-3/8	1-3/8	1-5/8	1-1/8	1-3/8	1-3/8
54,000	7/8	1-1/8	1-1/8	1-1/8	1-3/8	1-3/8	1-1/8	1-1/8	1-1/8	1-3/8	1-3/8	1-3/8	1-1/8	1-3/8	1-3/8	1-3/8	1-3/8	1-5/8	1-5/8	1-1/8	1-3/8	1-3/8
60,000	7/8	1-1/8	1-1/8	1-1/8	1-3/8	1-3/8	1-1/8	1-1/8	1-1/8	1-3/8	1-3/8	1-5/8	1-1/8	1-3/8	1-3/8	1-3/8	1-3/8	1-5/8	1-5/8	1-1/8	1-3/8	1-3/8
66,000	7/8	1-1/8	1-1/8	1-3/8	1-3/8	1-3/8	1-1/8	1-1/8	1-3/8	1-3/8	1-3/8	1-5/8	1-1/8	1-3/8	1-3/8	1-3/8	1-3/8	1-5/8	1-5/8	1-1/8	1-3/8	1-5/8
72,000	1-1/8	1-1/8	1-1/8	1-3/8	1-3/8	1-3/8	1-1/8	1-3/8	1-3/8	1-3/8	1-5/8	1-5/8	1-1/8	1-3/8	1-3/8	1-3/8	1-5/8	1-5/8	1-3/8	1-3/8	1-5/8	
78,000	1-1/8	1-1/8	1-3/8	1-3/8	1-3/8	1-5/8	1-1/8	1-3/8	1-3/8	1-3/8	1-5/8	1-5/8	1-1/8	1-3/8	1-5/8	1-5/8	1-5/8	2-1/8	1-3/8	1-3/8	1-5/8	
84,000	1-1/8	1-1/8	1-3/8	1-3/8	1-3/8	1-5/8	1-1/8	1-3/8	1-3/8	1-3/8	1-5/8	1-5/8	1-3/8	1-3/8	1-5/8	1-5/8	1-5/8	2-1/8	1-3/8	1-5/8	1-5/8	
90,000	1-1/8	1-3/8	1-3/8	1-3/8	1-5/8	1-5/8	1-1/8	1-3/8	1-3/8	1-5/8	1-5/8	2-1/8	1-3/8	1-3/8	1-5/8	1-5/8	2-1/8	2-1/8	1-3/8	1-5/8	1-5/8	
120,000	1-1/8	1-3/8	1-3/8	1-5/8	1-5/8	2-1/8	1-3/8	1-3/8	1-5/8	1-5/8	2-1/8	2-1/8	1-3/8	1-5/8	1-5/8	2-1/8	2-1/8	2-1/8	1-5/8	1-5/8	2-1/8	
150,000	1-3/8	1-3/8	1-5/8	1-5/8	2-1/8	2-1/8	1-3/8	1-5/8	1-5/8	2-1/8	2-1/8	2-1/8	2-1/8	1-5/8	1-5/8	2-1/8	2-1/8	2-5/8	1-5/8	2-1/8	2-1/8	
180,000	1-3/8	1-5/8	1-5/8	2-1/8	2-1/8	2-1/8	1-3/8	1-5/8	2-1/8	2-1/8	2-1/8	2-1/8	1-5/8	2-1/8	2-1/8	2-1/8	2-5/8	2-5/8	1-5/8	2-1/8	2-1/8	
210,000	1-3/8	1-5/8	1-5/8	2-1/8	2-1/8	2-1/8	1-5/8	2-1/8	2-1/8	2-1/8	2-1/8	2-5/8	1-5/8	2-1/8	2-1/8	2-1/8	2-5/8	2-5/8	2-1/8	2-1/8	2-1/8	
240,000	1-5/8	1-5/8	2-1/8	2-1/8	2-1/8	2-5/8	1-5/8	2-1/8	2-1/8	2-1/8	2-5/8	2-5/8	2-1/8	2-1/8	2-1/8	2-5/8	2-5/8	2-5/8	2-1/8	2-1/8	2-5/8	
300,000	1-5/8	2-1/8	2-1/8	2-1/8	2-5/8	2-5/8	2-1/8	2-1/8	2-1/8	2-5/8	2-5/8	2-5/8	2-1/8	2-1/8	2-5/8	2-5/8	2-5/8	3-1/8	2-1/8	2-5/8	2-5/8	
360,000	2-1/8	2-1/8	2-1/8	2-5/8	2-5/8	2-5/8	2-1/8	2-1/8	2-5/8	2-5/8	2-5/8	3-1/8	2-1/8	2-5/8	2-5/8	2-5/8	3-1/8	3-1/8	2-1/8	2-5/8	2-5/8	
480,000	2-1/8	2-1/8	2-5/8	2-5/8	2-5/8	3-1/8	2-1/8	2-5/8	2-5/8	2-5/8	3-1/8	3-1/8	2-1/8	2-5/8	2-5/8	3-1/8	3-1/8	3-5/8	2-5/8	2-5/8	3-1/8	
600,000	2-1/8	2-5/8	2-5/8	2-5/8	3-1/8	3-1/8	2-1/8	2-5/8	3-1/8	3-1/8	3-1/8	3-5/8	2-5/8	2-5/8	3-1/8	3-1/8	3-5/8	3-5/8	2-5/8	3-1/8	3-1/8	
720,000	2-1/8	2-5/8	3-1/8	3-1/8	3-1/8	3-5/8	2-5/8	3-1/8	3-1/8	3-5/8	3-5/8	4-1/8	2-5/8	3-1/8	3-5/8	3-5/8	4-1/8	4-1/8	3-1/8	3-5/8	3-5/8	
900,000	2-5/8	3-1/8	3-1/8	3-1/8	3-5/8	3-5/8	3-1/8	3-1/8	3-5/8	3-5/8	4-1/8	4-1/8	3-1/8	3-5/8	3-5/8	4-1/8	4-1/8	4-1/8	3-1/8	3-5/8	4-1/8	

**\* NOTES:**

- Sizes that are highlighted indicate maximum suction line sizes that should be used for risers. Riser size should not exceed horizontal size. Properly placed suction traps must also be used for adequate oil return. All sizes shown are for OD Type L copper tubing
- Suction line sizes selected at pressure drop equivalent to 2°F. Reduce estimate of system capacity accordingly
- Recommended liquid line size may increase with reverse cycle hot gas systems
- If system load drops below 40% of design, consideration to installing double suction risers should be made

**Table 6B. Recommended Line Sizes for R-22 (continued)\***

Suction Line Size															Liquid Line Size						System Capacity BTU/H
Suction Temperature															Receiver to Expansion Valve Equivalent Lengths						
0°F Lengths			-10°F Equivalent Lengths						-20°F Equivalent Lengths												
100'	150'	200'	25'	50'	75'	100'	150'	200'	25'	50'	75'	100'	150'	200'	25'	50'	75'	100'	150'	200'	
3/8	1/2	1/2	<b>3/8</b>	3/8	3/8	3/8	1/2	1/2	3/8	3/8	3/8	1/2	1/2	1/2	3/8	3/8	3/8	3/8	3/8	3/8	1,000
5/8	5/8	5/8	<b>1/2</b>	1/2	1/2	5/8	5/8	5/8	<b>1/2</b>	1/2	5/8	5/8	5/8	7/8	3/8	3/8	3/8	3/8	3/8	3/8	3,000
5/8	5/8	7/8	1/2	1/2	<b>5/8</b>	5/8	5/8	7/8	1/2	<b>5/8</b>	5/8	5/8	7/8	7/8	3/8	3/8	3/8	3/8	3/8	3/8	4,000
5/8	7/8	7/8	1/2	<b>5/8</b>	5/8	7/8	7/8	7/8	5/8	5/8	<b>7/8</b>	7/8	7/8	7/8	3/8	3/8	3/8	3/8	3/8	3/8	6,000
7/8	7/8	7/8	5/8	<b>7/8</b>	7/8	7/8	7/8	7/8	5/8	<b>7/8</b>	7/8	7/8	7/8	1-1/8	1-1/8	3/8	3/8	3/8	3/8	3/8	9,000
7/8	7/8	1-1/8	<b>7/8</b>	7/8	7/8	7/8	1-1/8	1-1/8	7/8	7/8	7/8	<b>1-1/8</b>	1-1/8	1-1/8	3/8	3/8	3/8	3/8	3/8	3/8	12,000
7/8	1-1/8	<b>1-1/8</b>	7/8	7/8	7/8	<b>1-1/8</b>	1-1/8	1-1/8	7/8	7/8	<b>1-1/8</b>	1-1/8	1-1/8	1-1/8	3/8	3/8	3/8	3/8	3/8	1/2	15,000
1-1/8	1-1/8	1-1/8	7/8	7/8	<b>1-1/8</b>	1-1/8	1-1/8	1-1/8	7/8	<b>1-1/8</b>	1-1/8	1-1/8	1-1/8	1-3/8	3/8	3/8	3/8	3/8	1/2	1/2	18,000
1-1/8	1-1/8	<b>1-3/8</b>	7/8	1-1/8	1-1/8	1-1/8	<b>1-3/8</b>	1-3/8	7/8	1-1/8	1-1/8	<b>1-3/8</b>	1-3/8	1-3/8	3/8	3/8	1/2	1/2	1/2	1/2	24,000
1-1/8	<b>1-3/8</b>	1-3/8	7/8	1-1/8	1-1/8	<b>1-3/8</b>	1-3/8	1-3/8	1-1/8	1-1/8	1-3/8	1-3/8	1-3/8	<b>1-5/8</b>	3/8	3/8	1/2	1/2	1/2	1/2	30,000
<b>1-3/8</b>	1-3/8	1-3/8	1-1/8	1-1/8	1-3/8	1-3/8	1-3/8	<b>1-5/8</b>	1-1/8	1-3/8	1-3/8	1-3/8	<b>1-5/8</b>	1-5/8	3/8	1/2	1/2	1/2	1/2	1/2	36,000
1-3/8	1-3/8	<b>1-5/8</b>	1-1/8	1-1/8	1-3/8	1-3/8	<b>1-5/8</b>	1-5/8	1-1/8	1-3/8	1-3/8	<b>1-5/8</b>	1-5/8	1-5/8	3/8	1/2	1/2	1/2	1/2	5/8	42,000
1-3/8	<b>1-5/8</b>	1-5/8	1-1/8	1-3/8	1-3/8	1-3/8	<b>1-5/8</b>	1-5/8	1-1/8	1-3/8	1-3/8	<b>1-5/8</b>	1-5/8	2-1/8	1/2	1/2	1/2	1/2	1/2	5/8	48,000
1-3/8	<b>1-5/8</b>	1-5/8	1-1/8	1-3/8	1-3/8	<b>1-5/8</b>	1-5/8	1-5/8	1-3/8	1-3/8	<b>1-5/8</b>	1-5/8	2-1/8	2-1/8	1/2	1/2	1/2	1/2	5/8	5/8	54,000
<b>1-5/8</b>	1-5/8	2-1/8	1-1/8	1-3/8	1-3/8	<b>1-5/8</b>	1-5/8	2-1/8	1-3/8	1-3/8	1-5/8	1-5/8	<b>2-1/8</b>	2-1/8	1/2	1/2	1/2	5/8	5/8	5/8	60,000
1-5/8	1-5/8	2-1/8	1-3/8	1-3/8	1-5/8	1-5/8	1-5/8	<b>2-1/8</b>	1-3/8	1-5/8	1-5/8	1-5/8	<b>2-1/8</b>	2-1/8	1/2	1/2	5/8	5/8	5/8	5/8	66,000
1-5/8	<b>2-1/8</b>	2-1/8	1-3/8	1-3/8	1-5/8	1-5/8	<b>2-1/8</b>	2-1/8	1-3/8	1-5/8	1-5/8	<b>2-1/8</b>	2-1/8	2-1/8	1/2	1/2	5/8	5/8	5/8	5/8	72,000
1-5/8	<b>2-1/8</b>	2-1/8	1-3/8	1-5/8	1-5/8	1-5/8	<b>2-1/8</b>	2-1/8	1-3/8	1-5/8	1-5/8	<b>2-1/8</b>	2-1/8	2-1/8	1/2	1/2	5/8	5/8	5/8	7/8	78,000
1-5/8	<b>2-1/8</b>	2-1/8	1-3/8	1-5/8	1-5/8	<b>2-1/8</b>	2-1/8	2-1/8	1-3/8	1-5/8	<b>2-1/8</b>	2-1/8	2-1/8	2-1/8	1/2	5/8	5/8	5/8	5/8	7/8	84,000
<b>2-1/8</b>	2-1/8	2-1/8	1-3/8	1-5/8	1-5/8	<b>2-1/8</b>	2-1/8	2-1/8	1-3/8	1-5/8	<b>2-1/8</b>	2-1/8	2-1/8	2-1/8	1/2	5/8	5/8	5/8	7/8	7/8	90,000
2-1/8	2-1/8	2-1/8	1-5/8	1-5/8	2-1/8	2-1/8	2-1/8	<b>2-5/8</b>	1-5/8	2-1/8	2-1/8	2-1/8	<b>2-5/8</b>	2-5/8	5/8	5/8	5/8	7/8	7/8	7/8	120,000
2-1/8	<b>2-5/8</b>	2-5/8	1-5/8	2-1/8	2-1/8	2-1/8	<b>2-5/8</b>	2-5/8	2-1/8	2-1/8	2-1/8	<b>2-5/8</b>	2-5/8	2-5/8	5/8	7/8	7/8	7/8	7/8	7/8	150,000
2-1/8	<b>2-5/8</b>	2-5/8	1-5/8	2-1/8	2-1/8	<b>2-5/8</b>	2-5/8	2-5/8	2-1/8	2-1/8	2-5/8	2-5/8	2-5/8	<b>3-1/8</b>	5/8	7/8	7/8	7/8	7/8	1-1/8	180,000
<b>2-5/8</b>	2-5/8	2-5/8	2-1/8	2-1/8	2-5/8	<b>2-5/8</b>	2-5/8	2-5/8	2-1/8	2-5/8	2-5/8	2-5/8	<b>3-1/8</b>	3-1/8	7/8	7/8	7/8	7/8	7/8	1-1/8	210,000
2-5/8	2-5/8	<b>3-1/8</b>	2-1/8	2-1/8	2-5/8	2-5/8	2-5/8	<b>3-1/8</b>	2-1/8	2-5/8	2-5/8	2-5/8	<b>3-1/8</b>	3-1/8	7/8	7/8	7/8	7/8	1-1/8	1-1/8	240,000
2-5/8	<b>3-1/8</b>	3-1/8	2-1/8	2-5/8	2-5/8	2-5/8	3-1/8	<b>3-1/8</b>	2-1/8	2-5/8	3-1/8	3-1/8	3-1/8	<b>3-5/8</b>	7/8	7/8	1-1/8	1-1/8	1-1/8	1-1/8	300,000
<b>3-1/8</b>	3-1/8	3-1/8	2-1/8	2-5/8	2-5/8	3-1/8	3-1/8	<b>3-5/8</b>	2-5/8	2-5/8	3-1/8	3-1/8	<b>3-5/8</b>	3-5/8	7/8	7/8	1-1/8	1-1/8	1-1/8	1-1/8	360,000
3-1/8	<b>3-5/8</b>	3-5/8	2-5/8	3-1/8	3-1/8	3-1/8	<b>3-5/8</b>	3-5/8	2-5/8	3-1/8	3-5/8	3-5/8	3-5/8	<b>4-1/8</b>	1-1/8	1-1/8	1-1/8	1-1/8	1-3/8	1-3/8	480,000
3-5/8	3-5/8	<b>4-1/8</b>	2-5/8	3-1/8	3-1/8	<b>3-5/8</b>	3-5/8	4-1/8	3-1/8	3-1/8	3-5/8	3-5/8	<b>4-1/8</b>	4-1/8	1-1/8	1-1/8	1-1/8	1-3/8	1-3/8	1-3/8	600,000
4-1/8	<b>4-1/8</b>	5-1/8	3-1/8	3-5/8	4-1/8	4-1/8	<b>5-1/8</b>	5-1/8	3-5/8	4-1/8	4-1/8	5-1/8	5-1/8	<b>5-1/8</b>	1-1/8	1-1/8	1-3/8	1-3/8	1-3/8	1-5/8	720,000
4-1/8	5-1/8	<b>5-1/8</b>	3-5/8	4-1/8	4-1/8	<b>5-1/8</b>	5-1/8	5-1/8	3-5/8	4-1/8	5-1/8	5-1/8	<b>5-1/8</b>	6-1/8	1-1/8	1-3/8	1-3/8	1-5/8	1-5/8	1-5/8	900,000

**\* NOTES:**

- Sizes that are highlighted indicate maximum suction line sizes that should be used for risers. Riser size should not exceed horizontal size. Properly placed suction traps must also be used for adequate oil return. All sizes shown are for OD Type L copper tubing
- Suction line sizes selected at pressure drop equivalent to 2°F. Reduce estimate of system capacity accordingly
- Recommended liquid line size may increase with reverse cycle hot gas systems
- If system load drops below 40% of design, consideration to installing double suction risers should be made

**Table 7. Recommended Remote Condenser Line Sizes**

Net Evap. Capacity	Total Equiv. Length	R-12 & R-134A		R-22		R-502		R-507 & R-404A	
		Discharge Line (OD)	Liquid Line Cond. to Receiver (OD)	Discharge Line (OD)	Liquid Line Cond. to Receiver (OD)	Discharge Line (OD)	Liquid Line Cond. to Receiver (OD)	Discharge Line (OD)	Liquid Line Cond. to Receiver (OD)
3,000	50	3/8	3/8	3/8	3/8	3/8	3/8	3/8	3/8
	100	1/2	3/8	3/8	3/8	3/8	3/8	3/8	3/8
6,000	50	1/2	3/8	3/8	3/8	3/8	3/8	1/2	3/8
	100	1/2	3/8	1/2	3/8	1/2	3/8	1/2	3/8
9,000	50	5/8	3/8	1/2	3/8	1/2	3/8	1/2	3/8
	100	5/8	3/8	1/2	3/8	1/2	3/8	5/8	3/8
12,000	50	5/8	1/2	1/2	3/8	1/2	3/8	1/2	3/8
	100	7/8	1/2	5/8	3/8	5/8	3/8	5/8	3/8
18,000	50	7/8	1/2	1/2	3/8	5/8	1/2	5/8	1/2
	100	7/8	1/2	5/8	3/8	5/8	1/2	5/8	1/2
24,000	50	7/8	5/8	5/8	1/2	5/8	5/8	7/8	5/8
	100	7/8	5/8	5/8	1/2	7/8	5/8	7/8	5/8
36,000	50	7/8	5/8	7/8	5/8	7/8	5/8	7/8	5/8
	100	1-1/8	5/8	7/8	5/8	7/8	5/8	7/8	5/8
48,000	50	1-1/8	7/8	7/8	5/8	7/8	7/8	7/8	7/8
	100	1-1/8	7/8	7/8	5/8	7/8	7/8	1-1/8	7/8
60,000	50	1-1/8	7/8	7/8	7/8	1-1/8	7/8	7/8	7/8
	100	1-3/8	7/8	7/8	7/8	1-1/8	7/8	1-1/8	7/8
72,000	50	1-1/8	7/8	7/8	7/8	1-1/8	7/8	1-1/8	7/8
	100	1-3/8	7/8	1-1/8	7/8	1-1/8	7/8	1-1/8	7/8
90,000	50	1-3/8	7/8	7/8	7/8	1-1/8	1-1/8	1-1/8	1-1/8
	100	1-3/8	7/8	1-1/8	7/8	1-1/8	1-1/8	1-3/8	1-1/8
120,000	50	1-3/8	1-1/8	1-1/8	1-1/8	1-1/8	1-3/8	1-1/8	1-1/8
	100	1-5/8	1-1/8	1-1/8	1-1/8	1-3/8	1-3/8	1-3/8	1-1/8
180,000	50	1-5/8	1-3/8	1-3/8	1-3/8	1-3/8	1-3/8	1-3/8	1-3/8
	100	2-1/8	1-3/8	1-3/8	1-3/8	1-5/8	1-3/8	1-5/8	1-3/8
240,000	50	1-5/8	1-5/8	1-5/8	1-3/8	1-5/8	1-5/8	1-5/8	1-5/8
	100	2-1/8	1-5/8	1-5/8	1-3/8	1-5/8	1-5/8	1-5/8	1-5/8
300,000	50	2-1/8	1-5/8	1-5/8	1-5/8	1-5/8	1-5/8	1-5/8	2-1/8
	100	2-1/8	1-5/8	1-5/8	1-5/8	2-1/8	1-5/8	2-1/8	2-1/8
360,000	50	2-1/8	1-5/8	1-5/8	1-5/8	1-5/8	2-1/8	2-1/8	2-1/8
	100	2-5/8	1-5/8	2-1/8	1-5/8	2-1/8	2-1/8	2-1/8	2-1/8
480,000	50	2-1/8	2-1/8	2-1/8	2-1/8	2-1/8	2-1/8	2-1/8	2-1/8
	100	2-5/8	2-1/8	2-1/8	2-1/8	2-1/8	2-1/8	2-1/8	2-1/8
600,000	50	2-5/8	2-1/8	2-1/8	2-1/8	2-1/8	2-5/8	2-1/8	2-1/8
	100	3-1/8	2-1/8	2-1/8	2-1/8	2-5/8	2-5/8	2-5/8	2-1/8
720,000	50	2-5/8	2-5/8	2-1/8	2-5/8	2-1/8	3-1/8	2-1/8	2-5/8
	100	3-1/8	2-5/8	2-5/8	2-5/8	2-5/8	3-1/8	2-5/8	2-5/8
840,000	50	2-5/8	2-5/8	2-1/8	2-5/8	2-5/8	3-1/8	2-5/8	3-1/8
	100	3-1/8	2-5/8	2-5/8	2-5/8	2-5/8	3-1/8	2-5/8	3-1/8
960,000	50	3-1/8	3-1/8	2-5/8	3-1/8	2-5/8	3-1/8	2-5/8	3-1/8
	100	3-1/8	3-1/8	2-5/8	3-1/8	2-5/8	3-1/8	3-1/8	3-1/8
1,080,000	50	3-1/8	3-1/8	2-5/8	3-1/8	2-5/8	3-5/8	2-5/8	3-1/8
	100	3-5/8	3-1/8	2-5/8	3-1/8	3-1/8	3-5/8	3-1/8	3-1/8
1,200,000	50	3-1/8	3-5/8	2-5/8	3-1/8	2-5/8	3-5/8	2-5/8	3-5/8
	100	3-5/8	3-5/8	3-1/8	3-1/8	3-1/8	3-5/8	3-1/8	3-5/8
1,440,000	50	3-1/8	3-5/8	2-5/8	3-5/8	3-1/8	4-1/8	3-1/8	3-5/8
	100	3-5/8	3-5/8	3-1/8	3-5/8	3-1/8	4-1/8	3-5/8	3-5/8
1,680,000	50	3-5/8	4-1/8	2-5/8	3-5/8	3-1/8	4-1/8	3-1/8	4-1/8
	100	4-1/8	4-1/8	3-1/8	3-5/8	3-5/8	4-1/8	3-5/8	4-1/8



## Leak Checking, Evacuation and Start-up

**Warning:** It is illegal to knowingly vent or discharge any CFC's and HCFC's to the atmosphere. ALL CFC's and HCFC's must be reclaimed or recycled.

### Leak Check

1. To check the systems for leaks, leave all valves closed on suction, liquid and hot gas manifolds. The unit is shipped with a holding charge of dry nitrogen and should be leak free. Build up the pressure in each circuit to a maximum of 150 psig dry nitrogen and check each individual circuit.
2. After each circuit has been checked, open all valves to allow the pressure into the unit assembly. Check to be sure pressure is throughout the assembly. Check all connections and accessories for leaks.

### Evacuation

1. After the system is leak checked, connect a good high vacuum pump with fresh oil to both the low and high side evacuation valves. Connections between the pump and evacuation valves should be made with copper tubing or high vacuum hose having a diameter of at least 3/8". Evacuate the system to 1500 microns for the first evacuation.
2. After each evacuation, the vacuum should be broken by the introduction of refrigerant into the system. The refrigerant should be passed through a drier when breaking the vacuum until the pressure is brought up to 0 psig.
3. Between the first and second evacuation, the liquid filter driers and suction filters should be installed in each replaceable core shell.
4. A triple evacuation is recommended. The third and final evacuation should achieve a value of 500 microns or less. After this vacuum is reached, add as much refrigerant as possible into the receiver. Now the system is ready to be started.

### Start-up

1. Set all pressure controls as recommended elsewhere in this manual. Recheck all service valves and shut-off valves to be sure they are open.
2. Check and be sure the condenser fan motors are running in the correct rotation.
3. All evaporator fan motors should be checked for proper rotation. The fans in low temperature boxes generally have a fan delay for defrost purposes that keep the fans from operating until the evaporator coil has reached a certain temperature. It will be necessary to jump-out the fan controls on freezer units to make them run through final charging and room temperature pull-down. The wiring diagram for the unit will have to be consulted to determine how to best force the fans to operate for this step.
4. With all compressor and control breakers and toggle switches turned off, apply power to the unit. If the unit is using a phase monitor, the green light must come on before going any further. (See instructions for phase protector elsewhere in this manual.) A red light indicates incorrect phasing or voltage. Check with a volt meter to see if correct voltage is connected to the unit. Correct the Power Supply before proceeding.
5. Turn on the circuit breaker for the control power. If an electronic control system is installed on the unit, it will initiate at this time. The Heatcraft preferred controller is manufactured by Computer Process Control (CPC). Review the manual for the controller supplied with the system.
6. Turn on circuit breakers to all compressors. The compressors can be started by turning on the compressor toggle switches. Likewise, each circuit control can be started by turning on the circuit toggle switch. It is recommended that one compressor at a time be started and checked before allowing them all to operate. It is also advisable to check one circuit at a time to be certain all components work when called upon and that the circuit wiring is correct.
7. When each circuit and compressor has been tested and the appropriate amount of refrigerant has been added for proper operation, allow the system to operate and pull-down the room/fixture temperatures.
8. Once the system is operating, set all regulating valves.
9. When the room and/or the fixture temperatures are at design, the expansion valves should be set. (See instructions elsewhere in this manual.)
10. Adjust the electronic or manual pressure controls as necessary to maintain proper pressures and temperatures.
11. Check the refrigerant level in the receiver. The minimum level that should be maintained is 20%.
12. All circuit defrost controls must be set and checked. Again, one circuit at a time should be tested.
13. Set condenser fan controls to maintain the proper discharge pressure.
14. All safety controls should be checked and verified. Check that the alarm circuitry is operating at this time.
15. Check the oil reservoir during the start-up and add oil as necessary. The oil level should be between the upper and lower reservoir sight glass. Do not add more than two gallons of oil to a system. If more oil is needed, recheck the piping as oil is not returning to the unit properly.

## Refrigerant Distribution

The distribution system is selected based upon the type of defrost for that particular system. For each set of liquid/suction lines a distribution system must be selected.

Liquid solenoids are recommended to be installed at the evaporator on all systems, particularly systems with long line runs. The solenoid will prevent continued feed to the evaporator through the expansion valve when it is not in operation. A solenoid is mentioned in each of the refrigerant distribution analysis, and are shipped loose to be installed at the evaporators.

Heatcraft offers three types of defrost: Off cycle defrost, Electric defrost and the Priority I hot gas defrost system for Racks. The type of defrost is generally a matter of either contractor or owner preference. Typical operation is as follows:

### Off-Cycle

The **off-cycle** system consists of liquid and suction line ball valves for circuit isolation, liquid solenoid and defrost controller. Defrost is initiated by the controller. The liquid solenoid closes pumping down the circuit, the evaporator fans remain in operation and room air melts the ice on the coil. The controller terminates the defrost period after a predetermined time period and opens the liquid solenoid putting the system back into refrigeration.

### Electric Defrost

The **electric** defrost system consists of liquid and suction line ball valves for circuit isolation, liquid solenoid, evaporator heater contactor, heater fusing, evaporator fan motor contactor and fuses if three phase fans are used, and defrost controller.

Defrost is initiated by the controller. The liquid solenoid closes, the evaporator fan contactor opens stopping the fans, and the defrost heater contactor is energized.

When the defrost heaters warm the coil to a predetermined level an adjustable defrost termination device within the evaporator signals the defrost controller to end the defrost period. A fan delay is provided at the end of each defrost cycle to allow the evaporator to cool before the fans start. This also prevents warm air and condensation from being discharged from the unit. The liquid solenoid opens putting the system back into refrigeration.

### Priority I Hot Gas Defrost

#### For Racks Only

The **Priority I Hot Gas Defrost** system consists of liquid and suction line ball valves for circuit isolation, liquid line solenoid with by pass check valve, suction solenoid valve, hot gas solenoid valve, liquid drain solenoid valve, liquid drain manifold, and defrost controller.

Defrost is initiated by the defrost controller closing the liquid solenoid and suction solenoid. The hot gas and liquid drain solenoids open (Unlike typical systems wherein the condensed liquid from the defrosting evaporator is returned into the liquid manifold, the Priority I design returns the liquid to the condenser through a liquid drain manifold).

Hot discharge gas is injected into the suction line at the parallel rack and flows to the evaporator being defrosted. The

discharge gas will condense into liquid as it flows through the cold evaporator.

The liquid exits the coil at the distributor side-port, then flows through the liquid line by pass check valve into the drain manifold and then returned to the condenser inlet.

The pressure in the condenser is controlled to be below the returning liquid pressure by a discharge gas regulator valve. The returning liquid pressure helps in driving refrigerate from the condenser to the receiver to maintain liquid refrigerant flows to the refrigerating evaporators. The Priority I system requires that no more than 20% of the evaporators defrost at one time.

The discharge gas regulator valve (DDGR) is normally set to maintain approximately 25 psig differential pressure. The next part of the Priority I system consists of a small capacity control system located at the compressor rack. The discharge gas bypass regulator valve should be set to maintain the normal suction pressure during normal refrigeration. There is a desuperheating TXV mounted to prevent overheating the suction line. The expansion valve should not require an adjustment as it is preset to maintain 20°F superheat. See page 31 of this manual for more information on the adjustment of the discharge gas bypass regulator valve.

### Head Pressure Control System

Almost all refrigeration systems require some form of year round head pressure control. This is due to the fixed amount of condenser surface which has been selected for summer conditions. During the winter, the condenser is oversized for the system and low head pressure will result. This will cause erratic operation of the system.

The following method of head pressure control is considered the most effective means and has the advantage of performing well at low outside ambient temperatures. The disadvantage is the fact that a relatively large quantity refrigerant must be used to flood the condenser and sufficient receiver storage must be provided during summer operation.

**Head pressure control system** consists of a condenser drain line valve and a discharge bypass valve. In order to maintain moderate head pressure the condenser drain valve senses condensing pressure. As condensing pressure falls in response to lower ambient temperatures, the drain valve will begin to restrict flow of liquid from the condenser filling condenser tubes with liquid refrigerant. This results in decreased surface area causing the discharge pressure to rise.

When pressure reaches the midpoint setting the valve begins to open allowing liquid to flow to the receiver. Simultaneously the discharge bypass valve installed in a line between the discharge manifold and the receiver maintains minimum receiver pressure to insure liquid flow.

## Electronic Control System

The electronic controller has become the standard on parallel compressor systems. The increased capabilities of the controllers magnify the efficiency of the parallel compressor system making it a very attractive accessory item.

The **electronic control system** preferred by Heatcraft is the Computer Process Control (**RMCC**) controller. The RMCC offers a complete control and monitoring package through one or more input boards (16AI). The controller continuously monitors the parameters for refrigerant pressures, defrost operation, temperature control, and system alarms.

As the RMCC monitors the system in operation, it compares the reported values against programmed set points it is to maintain, thus cycling compressors, unloaders, condenser fans, defrost periods and sounding alarms as required.

Interface with the actual devices being controlled is through one or more pressure transducers, watt transducer, temperature sensors, refrigerant sensors, humidity sensors, refrigerant level sensor, phase loss and output boards (8RO). The 8RO boards can be mounted remotely for lower installation cost, when controlling devices such as air cooled condensers. These boards are connected to the RMCC via a three wire network and are purchased as needed for the application. Remote communications capabilities is standard with the RMCC through a modem that is supplied.

## System Balancing

**Important:** In order to obtain the maximum capacity from a system, and to ensure trouble-free operation, it is necessary to balance **each and every** system.

## System Superheat

This is extremely important with any refrigeration system. The critical value that **must** be checked is **suction superheat**

Superheat is not preset at the factory.

Suction superheat should be checked at the compressor as follows:

1. Measure the suction pressure at the suction service valve of the compressor and determine the saturation temperature corresponding to this pressure from a "Temperature-Pressure" chart.
2. Measure the suction temperature of the suction line about one foot back from the compressor using an accurate thermometer.
3. Subtract the Saturated temperature from the actual suction line temperature. The difference is Superheat.

If suction superheat is too low, it can result in liquid refrigerant being returned to the compressor. This will cause dilution of the oil and eventual failure of the bearings and piston rings. In extreme cases, the compressor will fail as a result of the diluted oil.

High suction superheat will result in excessive discharge temperatures that can cause a breakdown of the oil. This action results in piston ring wear, piston and cylinder wall damage.

Also, as the superheat increases, the suction pressure decreases resulting in reduced capacity. For maximum system capacity, suction superheat should be kept as low as is practical. Heatcraft recommends that the superheat at the compressor be no lower than 20°F.

If adjustments to the suction superheat need to be made, the expansion valve at the evaporator should be adjusted. See instructions in next section.

## Evaporator Superheat

Check Your Superheat after the box temperature has reached or is close to reaching the desired temperature, the evaporator superheat should be checked and adjustments made if necessary. Generally, systems with a design TD of 10°F should have a superheat value of 6° to 10° F for maximum efficiency. To properly determine the superheat of the evaporator, the following procedure is the method Heatcraft recommends.

1. Measure the temperature of the suction line at the point the bulb is clamped.
2. Obtain the suction pressure that exists in the suction line at the bulb location by either of the following methods:
  - a) A gauge in the external equalized line will indicate the pressure directly and accurately
  - b) A gauge directly in the suction line near the evaporator or directly in the suction header of the evaporator will yield the same reading as above
3. Convert the pressure obtained in 2a or 2b above to saturated evaporator temperature by using a temperature-pressure chart.
4. Subtract the Saturated temperature from the actual suction line temperature. The difference is Superheat.

## Alternative Superheat Method

The most accurate method of measuring superheat is found by following the previous procedure, Temperature/Pressure method. However, that method may not always be practical. An alternative method which will yield fairly accurate results is the temperature/temperature method.

1. Measure the temperature of the suction line at the point the bulb is clamped (outlet).
2. Measure the temperature of one of the distributor tubes close to the evaporator coil (inlet).
3. Subtract the outlet temperature from the inlet temperature. The difference is approximate Superheat.

This method will yield fairly accurate results as long as the pressure drop through the evaporator coil is low.

## Compressors

The majority of the Heatcraft Parallel systems incorporate the Copeland compressor. Other brand compressors are available upon customer request. The compressors are solid mounted to a base frame or mounted on the refrigerant receiver. All reciprocating compressors incorporate oil floats. Crankcase heaters will be installed and wired. Cylinder head cooling fans will be installed on all low temperature reciprocating systems or as directed by the specific compressor manufacturer. A high pressure cutout and oil failure control are installed and wired for each compressor.

Many compressors are available with unloading for capacity control. The unloading of a compressor adds many capacity steps to those normally available to an electronic controller. Usually, the more steps available the better the load can be matched.

## Copeland Compressors

**Table 8. 3D/4D/6D Solid State Modules**

Control Voltage			
Model Number	Copeland Kit Number	Copeland Number	T.I. Number
<b>115 - 230 Volts</b>			
3D-FSM 4D/6D	998-0524-00	071-0524-00	31AA-1600E

**Table 9. Typical Voltage Ranges**

Voltage Code	60 Hertz Rating			50 Hertz Rating		
	Rating	Min.	Max.	Rating	Min.	Max.
B	230-1	207	253	-	-	-
C	208/230-3	187	253	200/220-3	180	240
D	460-3	414	506	380/420-3	342	462
E	575-3	518	633	500-3	450	550
K	208/230/460-3	187	506	200/380/400-3	180	440
M	-	-	-	380/420-3	342	462
N	230/460-3	207	506	200/400-3	180	440
U	200-3	180	220	-	-	-

Refer to voltage rating of specific models

**Table 10. Unloader Factors**

Model	Factors									
3D	See Copeland Application Bulletin Number AE 21-1278 Moduload - Capacity Control for 3D Compressors									
		Full Load			One Bank Unloading			Two Bank Unloading		
	Performance	HT	MT	LT	HT	MT	LT	HT	MT	LT
4D	CAPACITY	1.00	1.00	1.00	.50	.50	.50	-	-	-
	POWER	1.01	1.03	1.02	.56	.56	.56	-	-	-
	AMPS	1.01	1.03	1.02	.60	.60	.74	-	-	-
6D	CAPACITY	1.00	1.00	1.00	.70	.70	.70	.36	.36	.36
	POWER	1.01	1.03	1.02	.70	.71	.72	.40	.42	.43
	AMPS	1.03	1.04	1.02	.75	.77	.84	.55	.60	.72

Multiply compressor rating data by above factors when used with blocked suction unloading  
Refer to Copeland AE 17-1287 for Demand Cooling Restrictions on unloading

**Table 11. Oil Safety Switch**

Copeland Part No.	MFGRS.	Model No.	Pressure Diff. Psi (bar)		Alarm Circuit
			Cut-In	Cut-Out	
		Sentronic	7 - 9	12 - 14	Yes
085-0062-00	Penn	P45NCA-12	9 (± 2)	14	No
	Ranco	P30-5826			Yes
	Robertshaw	PD21-2502			No
085-0088-00	Robertshaw	PD21-1006			Yes
	Penn	P45NCB-3			Yes
085-0101-00	Robertshaw	LG21-2501			Yes

All controls are Manual Reset type with a 120 second nominal time delay at the rated voltage

**Table 12. Oil Charges**

Model Family	Standard		Deep Sump	
	Initial (oz)	Recharge (oz)	Initial (oz)	Recharge (oz)
2D	80	72	110	95
3D	115	105	190	170
4DA3-100E	140	130	-	-
4DL3-150E	135	120	250	235
4DA3-200E	135	120	250	235
4DT3-220E	130	120	245	235
4DH3-250E	130	120	245	235
4DJ3-300E	140	125	255	240
6D	140	130	255	245
6DT3-300*	255	245	255	245
6DJ3-400*	255	245	255	245

**Approved Copeland Lubricants**

Mineral Oil - Suniso 3GS or Equivalent

Alkyl Benzene - Copeland Ultra 200 / Shrieve Zerol 200 TD / Soltex AB 200A / Thermal Zone 200

POE - Copeland Ultra 22CC / Mobil EAL™ Arctic 22 CC / ICI Emkarate™ RL32CF / Thermal Zone 22CC

Bitzer Screw / Copeland Contour Screw compressor lubricant: Solest 170

**Carlyle Compressors**

**Approved Carlyle Lubricants**

**For CFC and HCFC Refrigerants Use:**

Totaline 150 / Suniso 3GS / Shrieve Zerol 150 /Texaco WFI-32-150 / IGI Petroleum Cryol-150

**For HFC Refrigerants Use:**

CPI Solest 120 /ICI Emkarate™ RL68H / +Lubrizol Lubrikuhl 29165 / \*Mobil Arctic EAL™ 68 / \*Castrol SW68 + Lubrizol ISO68 also sold under Texaco Capella HFC 68NA brand

\* Medium temperature applications only

**Oil Pressure**

The O6D and O6E oil pump is a positive displacement vane type. It produces high volume oil flow at a low oil pressure. The compressor utilizes an internal pressure regulator valve to maintain oil pressure at a constant 12 to 36 psi above suction pressure.

**Table 13. O6D/E Oil Pressure History**

	O6D Models Psi (bar)	O6E Models Psi (bar)
Before May 1984 (Prior S/N 2084J...)	12 to 18 (.83 to 1.24)	12 to 18 (.83 to 1.24)
May 1984 to March 1994 (Between S/N 2084J... & 1094J)	16 to 22 (1.1 to 1.52)	16 to 22 (1.1 to 1.52)
Starting March 1994 (Starting S/N 1094J...)	18 to 26 (1.24 to 1.8)	18 to 34 (1.24 to 2.3)

**Table 14. Oil Safety Switch**

Carlyle Part No.	Danfoss Part No.	Time Delay	Pressure Diff. Psi (bar)		Reset
			Cut-In	Cut-Out	
634-2008 OR P529-2130	60B2101	45 sec.	8 - 11 (.55 - .76)	4 - 8 (.28 - .55)	Manual
634-2050 OR P529-2100	60B2151				

Carlyle Part No.	Johnson Part No.	Time Delay	Pressure Diff. Psi (bar)		Reset
			Cut-In	Cut-Out	
O6DA660115	P345	45 sec.	8 - 11 (.55 - .76)	4 - 8 (.28 - .55)	Manual

**Table 15. Part Load Performance Multipliers**

Compressor Model	Multiplication Factor For 1 Bank Unloaded			Multiplication Factor For 2 Bank Unloaded		
	Capacity	Power	EER	Capacity	Power	EER
All 4 Cylinder Models	.49	.57	.86	-	-	-
All 6 Cylinder Models	.67	.73	.92	.32	.46	.70

**Table 16. Required Differential Pressure for Unloader Operation**

Application	Suction Pressure Range Psi (bar)		P Required-Discharge Minus Suction Pressure Psi (bar)			
			O6D		O6E	
	L.T. R-502, 404A, 507	10-25	(1.7-2.7)	30	(2.1)	30
M.T. R-502, 404A, 507	30-60	(3.1-5.2)	40	(2.8)	45	(3.1)
L.T. R-12, 134A	10-30	(1.7-3.1)	30	(2.1)	35	(2.4)
M.T. R-22 or H.T. R-22	30-90	(3.1-7.2)	50	(3.5)	55	(3.8)

Multiply compressor rating data by above factors when used with blocked suction unloading

### 3-Phase Voltage Monitor

The microprocessor-based voltage and phase sensing circuit constantly monitors the three phase voltages to detect harmful power line conditions. When a harmful condition is detected, the phase monitor output relay is deactivated after a specified trip delay. The output relay reactivates after power line conditions return to an acceptable level for a specified amount of time (Restart Delay). The trip delay prevents nuisance tripping due to rapidly fluctuating power line conditions.

The Bicolor LED indicator light is green in normal conditions and red during trip conditions. On initial start-up, if the light is continuously red, the unit electrical phase may need to be reversed. Each main power line should be checked for proper voltage and imbalance prior to reversing a phase. Also check the settings of the Voltage Monitor for proper field condition.

For semi-hermetic compressor units, two of the three power monitor leads on the Voltage Monitor to L1, L2, and L3 may need to be switched. For units with Scroll\* or Screw compressors, which are rotation sensitive, two of the main power lines to the compressor unit will have to be switched to match the correct rotation of the compressors. The rotation of Screw and Scroll\* compressors has been properly phased in the manufacturing plant prior to shipping.

## Sight Glass & Moisture Indicator

The sight glass/moisture indicator helps determine that a unit has sufficient refrigerant charge and/or when the liquid line filter drier cores need to be replaced.

Bubbles in the glass may indicate a shortage of refrigerant or a restriction in the liquid line (i.e. plugged liquid line filter drier). Moisture typically results from a leak in the refrigerant system or service operations which open the refrigerant system to the atmosphere.

Moisture is detrimental because it leads to the formation of acids which attack components in the system. A change of color in the indicating dial from green to either chartreuse or yellow indicates unacceptable moisture in the system in which case the liquid line filter drier cores need to be changed.

Upon changing the cores, the indicating dial should return to green within 12 hours of returning system to operation.

**Figure 10. Sight Glass**

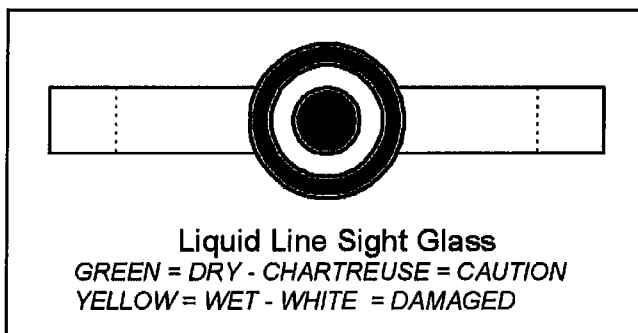

## Safety Relief Devices

A refrigerant Safety Relief Device is designed to prevent pressure in a Vessel from rising above a safe limit when operating controls fail or when the Vessel is exposed to excessive heat.

When a Vessel, containing liquid refrigerant, is shut off from other parts of the system a rise in temperature will cause a rise in pressure. If the Vessel is completely filled with liquid a small rise in temperature will cause a rapid and excessive rise in pressure due to the expansion of the liquid. If the Vessel contains both liquid and vapor, which is normal for Refrigerant Receivers, the pressure will rise according to the temperature-pressure saturation characteristic of the refrigerant.

If pressure builds up high enough to cause the Vessel to rupture, large quantities of liquid refrigerant are released. This causes a sudden reduction of pressure so that the liquid released is vaporized almost instantly with explosive results.

With a suitable Relief Device installed on the Vessel, the refrigerant is released at a controlled rate and a safe pressure is maintained in the Vessel.

**Figure 11. Direct Type Relief Valves**

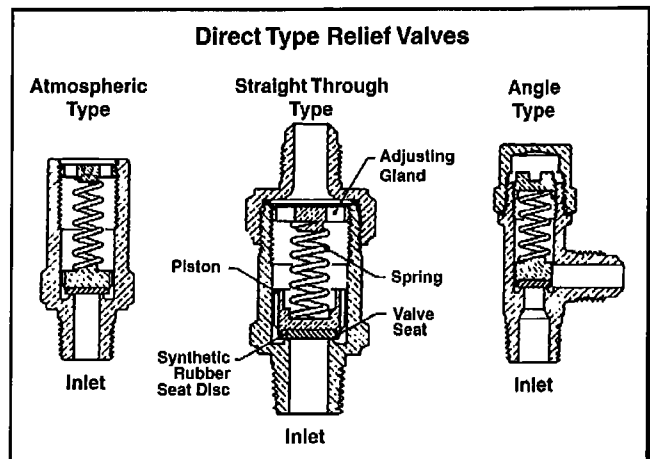

After a "Direct Type" Relief Device has discharged once, it should be replaced. The "Direct Type" Relief Device is designed to re-close automatically at a predetermined pressure, but reliability of the Device to reseal tightly and to operate at the designed pressure can not be guaranteed after discharging. Be safe and replace the Device after such an occurrence.

**Figure 12. 3-Way Relief Valve**

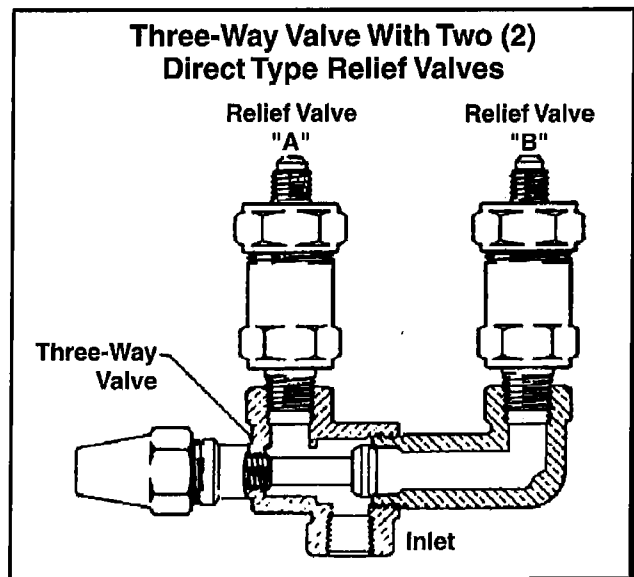

**Table 17. Henry Relief Valve Capacity Rating**

Type	Catalog Number	Size Connection		Standard Pressure Settings PSIG			
		Inlet	Outlet	350	400	425	450
Angle	526E	3/8 MPT	3/8 FLARE	10.2	11.6	12.3	13.0
	527E	1/2 MPT	5/8 FLARE	28.5	32.4	34.4	36.3
Straight Through	5231	3/8 MPT	3/8 FLARE	11.2	12.7	13.5	14.3
	5231-A	3/8 MPT	1/2 FLARE	18.6	21.1	22.4	23.7
	5231	1/2 MPT	5/8 FLARE	18.6	21.1	22.4	23.7
	5232	1/2 MPT	5/8 FLARE	28.1	32.0	33.9	35.8
	5240-1/2	1/2 MPT	3/4 FPT	41.2	46.8	49.1	52.5
	5242-3/4	3/4 MPT	3/4 FPT	41.2	46.8	49.1	52.5
	5244-1	1 MPT	1 FPT	74.0	84.2	89.3	94.4
	5246-1-1/4	1-1/4 MPT	1-1/4 FPT	129.7	147.5	156.4	165.4

**Table 18. Discharge Piping Table**

Maximum Length of Discharge Pipe in Feet * For 400 PSIG Pressure Setting									
Relief Device Capacity Lbs. Air/Min.	Soft Copper Tube (OD)			Schedule 40 Pipe					
	3/8"	1/2"	5/8"	1/2"	3/4"	1"	1-1/4"	1-1/2"	2"
10	3-1/2	19-1/4	61	108	445				
12	2-1/2	12-1/4	44	75	308				
14	2	9-1/2	32	56	228				
18		5-1/4	19-1/4	33	137				
20		4-1/4	16	28	110	371			
25		2-1/2	9-1/2	18	72	238			
30		2	7	12	49	165			
35		2	5-1/4	9	37	121			
40			3-1/2	7	28	93	366		
50			2-1/2	4	18	60	233		
70				3	9	30	119	257	
80				2	7	23	91	198	
90				2	5	18	72	156	
125					3	10	37	81	282
150					2	7	26	56	196

For Relief Devices set at 400 psig

- Obtain the capacity at 400 psig setting

- Locate this capacity or the nearest larger capacity in the left-hand column of the discharge piping table above and read across to obtain the maximum lengths for each tube and pipe size

For relief devices set at 350 psig, use the above table and multiply by .75 to determine maximum lengths

For relief devices set at 425 psig, use the above table and multiply by 1.15 to determine maximum lengths

For relief devices set at 450 psig, use the above table and multiply by 1.25 to determine maximum lengths



## Series P100 Pressure Control

The P100 series, manufactured by Johnson Control, Inc., are encapsulated, non adjustable, single-pole single throw, direct mount pressure controls typically used for low or high pressure cutouts. On the Heatcraft manufactured parallel systems, the control is used for High Pressure cutout.

There are two types available. Auto Reset Models and Manual Reset Models.

**Figure 13.**

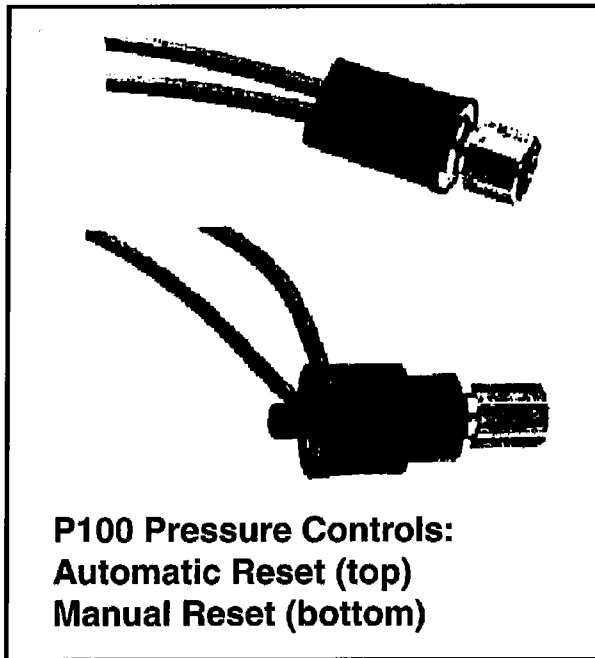

### Auto Reset Models

When pressurized to the selected actuation pressure setting, the internal snap-acting disc reverses its shape and drives a set of electrical contacts either open or closed. When the pressure drops below the de-actuation pressure setting, the disc snaps back to its preset position thus resetting the electrical contacts.

### Manual Reset Models

The snap-acting disc in the manual reset model opens the electrical contacts when actuated by the pressure sensor. Once the disc snaps, the contacts are held open until an external force on the push button closes them. Because of the disc's link with the pressure sensor, the contacts cannot be reset until the pressure drops to a predetermined level.

The latching mechanism inside the manual reset model is trip free. The electrical contacts will cutout even if the reset button is held fully depressed. The control can only be reset when the pressure returns to a predetermined level.

## Liquid Level Switch

### S-9400 Level Switch Series

OPTION – Not available on all systems or receivers.

**Table 19. Level Switch Table**

Cat. No.	Voltage	Resistive Rating	Contacts Liq. Present
S-9420	208/240 50/60 Hz	.5 Amp	N.C.

Cat. No.	Wire Color Code	Replacement Module No.	Replacement Sight Glass No.
S-9420	Red & White	2-044-015	3-020-063

**Figure 14.**

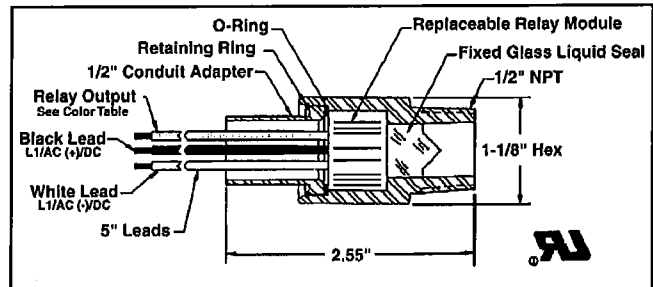

### Operation

The S-9400 Series Level Switches manufactured by AC&R COMPONENTS uses light reflecting from a conical glass prism as a means of detecting the absence of a fluid at the level of the glass cone. When no fluid covers the lower half of the cone, infra-red light from the module reflects from the mirror-like inner surface of the cone back to a light detector signaling the electronic module to switch. When fluid covers the lower half of the glass cone, the light from the module passes into the fluid. This absence of light is detected by the module which switches into the opposite direction. The module provides a .06/.10 differential distance from the cone point down.

## Module Replacement

1. Disconnect power at the fuse box
2. Remove wiring box from the retainer
3. Remove the IRR 4000-93 Ring with an IRR P-101 or equivalent retaining ring pliers
4. Remove the Retainer
5. Pull out the module by the leads
6. Install new Module
7. Verify the voltage rating
8. Reassemble the Retainer, Ring, and wiring

**Figure 15.**

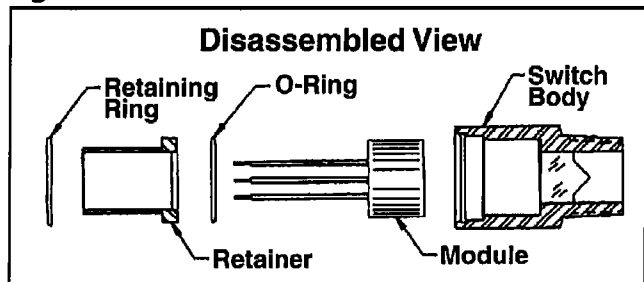

## Oil Control

A proper oil control system is essential to insure compressor lubrication. An oil control system can be very cost effective alternative to replacing expensive compressors due to loss of oil. Oil traveling through the system tends to build up in the evaporator, condenser, and vessels of a refrigeration system. This causes a lack of oil return to the compressor until finally, a large amount returns as a "slug" of oil.

A slug of oil down the suction line can be just as damaging to the compressor as a slug of liquid refrigerant. This delay in oil return requires an additional amount of oil to be added to the system, depending on the size of the system, the piping, the temperatures, the miscibility of the refrigerant/oil mix, and the refrigerant velocity.

By removing oil from the discharge gas of compressors, not only is the oil level for each compressor more accurately controlled, the efficiency of the system is increased. Oil does not change phase from liquid to gas in a refrigeration system and therefore makes a very poor refrigerant. Oil also takes up volume through the system that otherwise could be filled with refrigerant. Additionally, oil tends to film the condenser tubing wall lowering heat transfer and as oil and refrigerant exits the expansion valve, the oil will foam insulating the evaporator walls and again lowering heat transfer.

**IMPORTANT:** An oil control system does not replace the need for proper system design. An oil control system will drastically reduce the amount of oil going through the system. Correct piping, suction traps, and proper sizing of valves, controls, and components must still be implemented to insure the system will work properly.

## Low Pressure Oil System

This type system is normally used for parallel compressors and uses three basic components: Oil Separator, Oil Reservoir, and Oil Level Regulators. The common discharge is piped to the inlet of the oil separator and the outlet of the oil separator is piped to the condenser. An oil return line is brought from the oil separator to the top valve of the oil reservoir. A vent line is installed to the suction line with a pressure valve in line to lower the pressure in the reservoir, making a low pressure oil system. This valve will keep the reservoir pressure a set pressure above suction depending on the value of the valve, either 5 or 20 psig to the oil level regulator. Mechanical oil level regulators are rated for pressures ranging from 5 to 90 psig differential. The bottom valve of the oil reservoir is piped to oil level regulators mounted on the compressor crankcases. These regulators open to feed oil as the oil level drops and closes as the oil level raises to the set level. In this manner, the oil level in the compressor is kept at a constant level. Either one oil strainer per regulator or one oil filter per separator must be used to remove debris from the oil.

**Figure 16. Low Pressure Oil System**

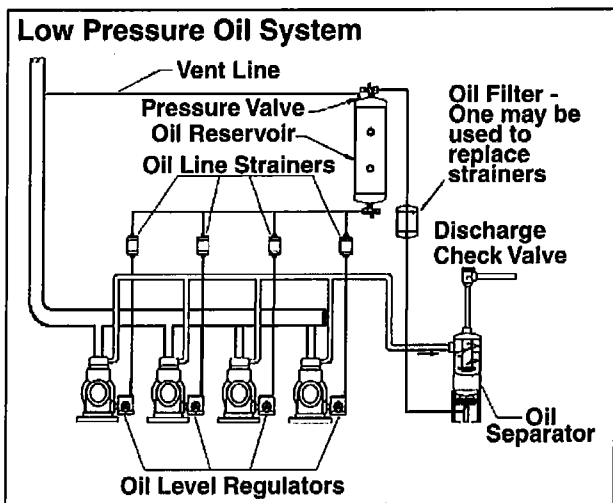

## Oil Separators

There are two types of oil separator that may be used in the Heatcraft parallel racks. One type utilizes the standard impingement screen. This type separator works by having the compressed mass flow enter into a large separator chamber which lowers the velocity and then the atomized oil droplets collect on the impingement screen surface. As the oil droplets collect into larger particles they fall to the bottom of the separator.

The second separator more commonly used is the coalescent type. This type separator contains a matrix type borosilicate coalescent filter to do the work impingement screens formerly did. The exceptionally pure, extremely fine glass fibers matrices excite the oil molecules to collide into one another thus agglomerating them into bigger droplets until they are forced to the outer drain layer of the filter. These droplets fall to the bottom of the separator reservoir and the oil is then returned

to the compressor.

Before the oil separator is installed, an initial charge of oil must be added to it. This initial charge of oil is the amount that is needed to just float the needle valve float. This amount of oil will stay in the oil separator when in operation and will seal the needle and prevent damage to the float mechanism. Oil Precharge is very important. Failure to Precharge the separator sump may result in damage to the oil return float mechanism by the turbulent hot gas bouncing the float and causing the needle valve to leak.

New systems from the factory have been Precharged. Use the same type of oil that is in the compressor crankcase. **See the table below for the proper amount of oil to be Precharged.**

**Table 20. AC&R Models**

Helical Model No.	Oil Precharge
S-5180, S-5181	4 oz. / 11 cl
S-5182, 85, 87, 88	14 oz. / 40 cl
S-5190, 92, 94	40 oz. / 114 cl
S-5200 / S-5410 series	25 oz. / 71 cl

Conventional Model No.	Oil Precharge
S-5500 series	12 oz. / 34 cl
S-5600 series	30 oz. / 86 cl
S-1900, S-5700 series	25 oz. / 71 cl
S-5800 series	12 oz. / 34 cl

## Temprite Models

The Temprite brand used is the coalescent filter type separator. Because this filter is finer than a filter/drier, it will pick up any and all effluent and dirt circulating in the system down to 0.3 microns. These filters should be changed after 24 to 48 hours of initial run time. A second filter is supplied with the system for this purpose. If the filter becomes dirty, it will not function at its optimum performance level. In the event of a compressor burnout, all the effluent will be contained in the oil separator.

When the Temprite coalescent separator is used, the separate oil reservoir is not required. The oil separator serves the additional function as the reservoir. There is a constant pressure valve used between the oil return outlet and the oil level regulators to maintain a low pressure oil flow to the regulators. This valve should be adjusted to maintain oil pressure to the level regulators at 20 psig higher than the highest suction pressure group. This valve can be adjusted by removing the external cap and rotating the adjusting spring in or out as required.

The valve currently used is manufactured by Parker and is a model A7 constant pressure expansion valve with a range of 0 to 90 psig. Temprite Part No. is 67070000. An alternative valve manufactured by Sporlan is Model ADRI - 1<sup>1</sup>/<sub>4</sub> - 0/90.

## Temprite Valve Adjustment

Turn in (clockwise) to increase pressure. Turn out (counterclockwise) to decrease pressure. Approximately 7 psi per turn. Factory set at 40 psi ±2.

**Table 21. Temprite Models**

Temprite Model No.	Oil Precharge
922R, 923R	77 oz. / 2.2 L
924R, 925R	109 oz. / 3.22 L
926R, 927R	1.8 gal. / 6.7 L
928R	3.5 gal. / 13.25 L
930R	5.7 gal. / 21.25 L

**Figure 17. Temprite Oil System**

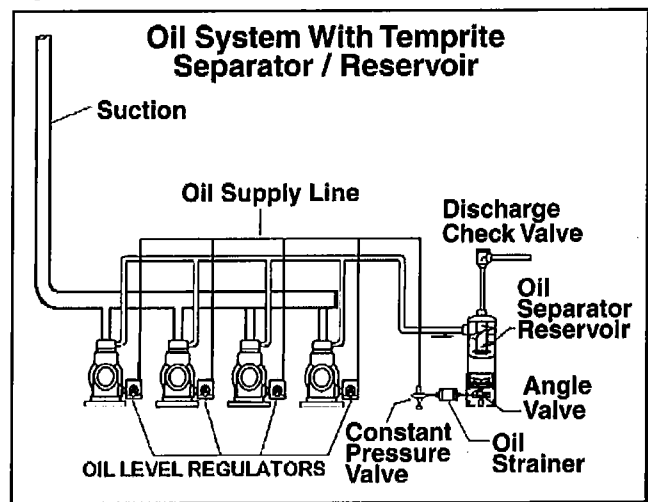

## Oil Level Regulators

The AC&R adjustable oil regulators are designed to feed oil between 1/4 and 5/8 sight glass levels. The regulator may adjust beyond this range due to the actual oil pressure. Adjustable regulators include an adjustment mechanism to raise or lower the oil set point. The AC&R design eliminates the need to shut the system down in order to adjust the oil level. The oil level may be adjusted while the system is under pressure and running. Adjust the oil level by removing the seal cap, the locking disk (S-9130 & S-9190 series only), and rotating the adjustment clockwise to lower, counter clockwise to raise the oil level. Replace the cap and locking disk when done. Each full turn of the adjustment mechanism moves the oil level approximately 1/16". Oil levels on these regulators are typically factory set just below 1/2 sight glass.

All level regulators have a operating pressure differential range that should not be confused with its working pressure. The operating differential is the difference of pressure between the oil feeding into the regulator and the component where the regulator is controlling oil level. Specifically, the reservoir pressure minus the crankcase pressure. If the differential pressure is too low for that regulator, insufficient oil flow to the compressor may result. If the differential pressure is too high, the regulator will overflow.

**Table 22. AC&R Model Regulators**

AC&R Model No.	Connection Size	Operation Pressure Diff., psig	Oil Level, Sight Glass
S-9010	3 BOLT	5 - 30	1/2
S-9010A	4 BOLT	5 - 30	1/2
S-9015	3/4" NPTF F.	5 - 30	1/2
S-9090	3 BOLT	5 - 90	Adjustable
S-9090A	4 BOLT	5 - 90	Adjustable
S-9110	3 BOLT	5 - 30	1/2
S-9120	3 BOLT	5 - 30	1/4 +
S-9130	3 BOLT	5 - 90	Adjustable
S-9190	3 BOLT	30 - 90	Adjustable

### Troubleshooting Oil System

The oil return line should always be checked. Feeling the oil return line and seeing how often it gets hot is the main way to tell if the separator is working properly. It is easier if an oil line sight glass is installed, mainly because if the oil line is hot you don't know if it is oil or hot gas causing it to be hot. If the oil line cycles between hot and cold at least a few times per hour, the separator is most likely working properly. The float tends to open and feed a few ounces of oil at a time and shut until the oil builds back up. If the oil return is cycling there is no need to drain the separator to look at the float components.

Always check the oil reservoir level during a service call. Oil levels in the reservoir will normally vary during periods of varying loads: compressors shutdown, hot-gas defrost, etc. This is normal, however if the level is consistently low or high, the oil system should be checked thoroughly.

Compressor oil levels can be deceiving. It is sometimes hard to tell if the regulator is feeding oil or if oil is coming down the suction line. If the reservoir has too much pressure, often times this pressure will force oil out of the regulator and show a low level, even though there may be excessive oil in the compressor. Many times the best way to check the oil in the compressor is to shut off the oil feeding to the regulator while the compressor is operating and wait a few minutes. If oil is pushed out of the regulator or trapped in the motor cavity on semi-hermetic models, the compressor will overflow.

The oil line sight glass is a good way to see how the separator is working. Look for movement in the glass. If the separator is not feeding on single or low pressure systems, the sight glass will have little or no movement and normally will appear empty. If the separator is feeding, the sight glass will show a rush of oil and foam past the glass. Most of the time, viewing this sight glass can prevent having to open the system.

To check the oil level in the separator if the separator has a drain, shut off the oil return line to prevent further feeding, pump down the system, shut off the system, evacuate the separator, and drain the oil from the bottom.

The separator should hold the pre-charge amount plus or minus a few ounces during operation. By looking at the amount above or below the pre-charge, any problem with the separator or float can be determined.

Note that there is no way to clean or repair welded oil separators. If it is determined that the float is clogged or otherwise malfunctioning, the entire oil separator must be replaced.

When the refrigerant and/or oil types are changed in a system, there is the potential for leaks around o-ring seals. Most elastomers absorb oil and refrigerant and may swell or shrink when exposed to a new oil or refrigerant. In these cases replace the o-rings and seals in the system as needed.

### Liquid Filter-Driers & Suction Filters

A replaceable core liquid filter/drier is supplied as standard on all Rack units and is an option in all other parallel systems. A Schrader type access valve is installed in the flange plate of some models. The liquid cores are always shipped loose for field installation. (See No. 5 of Leak Checking, Evacuation, and Start-up section in this manual).

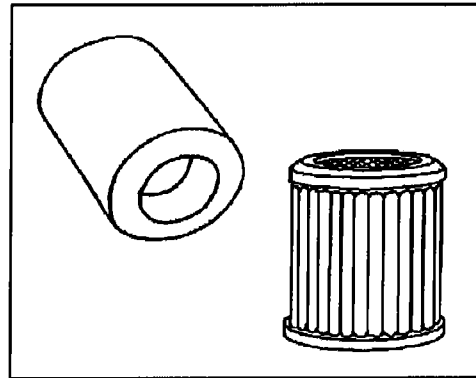

**Table 23. Sporlan Valve Co.**

Sporlan Model	No. Of Cores	Desiccant Volume (cu. in.)	# Core Part No.
C-489-(G)	1	48	RC-4864 RC-4864-HH RCW-48
C-969-(G)	2	96	
C14411-(G)	3	144	
C-19211-(G)	4	192	
C-4021-(G)	4	192	
C-4025-(G)	4	192	

"G" indicates flange plate supplied with \_" FPT  
 # "RC\_" Standard Core, "RC\_HH" Burnout Core  
 "RCW\_" High Water Capacity

**Table 24. Alco Controls**

Alco Model	No. Of Cores	Desiccant Volume (cu. in.)	# Core Part No.
STAS-489-T*	1	48	D-48 H-48 UK-48 W-48
STAS-969-T	2	96	
STAS-14411-T	3	144	
STAS-19211-T	4	192	
STAS-19213-T	4	192	
STAS-19217-T	4	192	

\* "T" indicates Liquid Line Service  
 # "D" Standard Capacity, "H" High Capacity  
 "UK" High Capacity, "W" Burnout Block

## Suction Filter

Replaceable core suction filters are supplied as standard on all units. The flanged shell holds replaceable pleated filter elements suitable for installation in the suction line of refrigeration systems. In this way any contaminants left in the system at start-up can be removed before they circulate back to the compressor. The suction filters are shipped loose for field installation. (See No. 3 of Leak Checking, Evacuation, and Start-up section in this manual).

## Compressor Motor Burnout Cleanup Procedure

Another benefit of the suction filter is its use in cleanup of a system after a burnout. Standard liquid cores can be installed in the shell to aid in the cleanup of acids and other contaminants from a motor burnout.

The following procedure can be used in case of a motor burnout.

1. Determine the extent of the burnout. For mild burnout's where contamination has not spread through the system, it may be economical to save the refrigerant. Normally it is economical to save the refrigeration charge if the system has service valves. A severe burnout exists if the oil is discolored, an acid odor is present and contamination products are found in the high and low side. With this condition, extreme caution should be exercised to avoid breathing the acid vapors and to prevent contaminated liquid from making contact with the skin.
2. Thoroughly clean and replace all system controls, such as expansion valves, solenoids, check valves, reversing valves, oil separators, suction accumulators, etc. Remove all strainers and filter-driers.
3. Install a replacement compressor and make a complete electrical check.
4. Make sure the suction line adjacent to the compressor is clean. Install a liquid line filter-drier or a replaceable cartridge designed for "cleanup" into the suction line shell.
5. Install a burnout core in the liquid line shell.
6. If the refrigerant is removed from the system, follow the evacuation procedure found on page 17 of this manual.
7. Start the compressor and put the system in operation. Record the pressure drop across the suction line filter and keep for reference.
8. Replace the suction line filter-drier blocks if the pressure drop becomes excessive.
9. Observe the system during the first 4 hours. Repeat step 8 as often as required, until no further change in pressure drop is observed.
10. After the system has been in operation for 48 hours, check the condition of the oil for Acids. If the oil test indicates an acid condition, replace the liquid and suction line filter-driers.
11. Check the system again after approximately 2 weeks of operation. If the oil is still discolored, or checks acid, replace the liquid and suction line filter-driers.
12. Cleanup is complete when the oil is clean, odor free, and is determined to be acceptable by testing for acids or other contaminants.
13. Replace the suction line filter-drier with suction line filters cores to minimize suction line pressure drop and to provide maximum compressor protection.

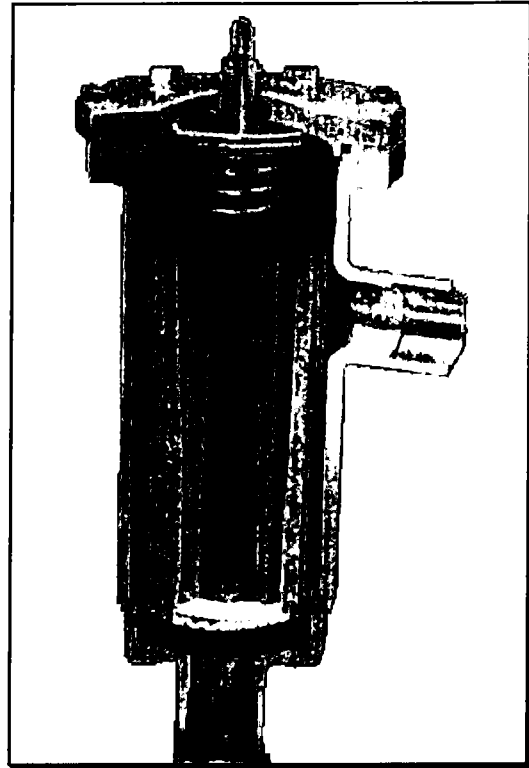

For more detailed information on burnout cleanup procedures and recommendations, consult the RSES Service Manual, section 91.

## Sporlan Valve Company

### Replaceable Suction Filter

The correct replacement suction filter element in Sporlan Valve replaceable shells is Sporlan part number RFE-48-BD. However any suitable filter that is sized to fit a 48 cu. inch vessel will substitute.

## Superior Valve Company

### Replaceable Suction Filter

- On many parallel systems, the Superior Valve Co. suction filter is installed.

**Table 25. Type F Filter**

### Replaceable Cartridges -

Shell No.	Catalog No.	IBCA No.	Cartridge OD (in.)	Filter Area (in <sup>2</sup> .)
2CFA	F25A	51071	1-23/32	66
3CFA	F35A	51072	2-5/8	115
4CFA	F45A	51073	3-17/32	189
5CFA	F55A	51074	4-1/16	270

**Table 26. Type DF (for cleanup)**

### Replaceable Cartridges -

Shell No.	Catalog No.	IBCA No.	Cartridge OD (in.)	Filter Area (in <sup>2</sup> .)
2CFA	DF25A	51053	1-23/32	66
3CFA	DF35A	51059	2-5/8	115
4CFA	DF45A	51060	3-17/32	189
5CFA	DF55A	51061	4-1/16	270

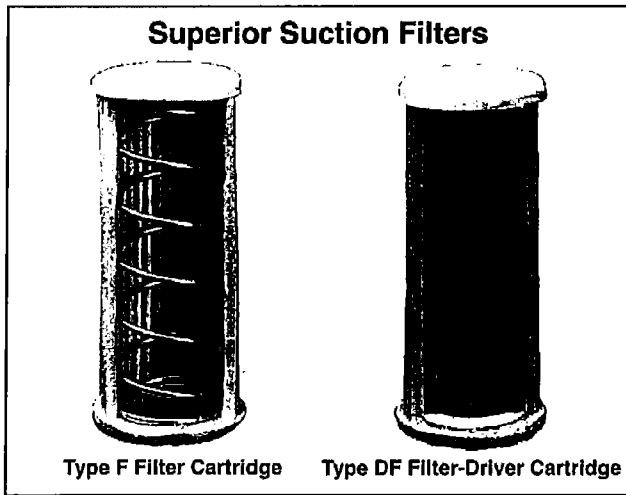

## Alco Controls

### Alco Suction Filter

Comparable to the Superior suction filters and interchangeable cores.

**Table 27. Type AF Filter**

### Replaceable Cartridges -

Shell No.	Filter Core	Cartridge OD (in.)	Filter Area (in <sup>2</sup> .)
BTAS-2	A2F	1-29/32	66
BTAS-3	A3F	2-3/4	115
BTAS-4	A4F	3-3/4	189
BTAS-5	A5F	4-5/16	270

**Table 28. Type AFD (for cleanup)**

### Replaceable Cartridges -

Shell No.	Filter Core	Cartridge OD (in.)	Filter Area (in <sup>2</sup> .)
BTAS-2	A2F-D	1-29/32	66
BTAS-3	A3F-D	2-3/4	115
BTAS-4	A4F-D	3-3/4	189
BTAS-5	A5F-D	4-5/16	270

## Head Pressure Control

In a system with variable pressure control the receiver pressure is maintained at the desired pressure by supplying discharge gas to it through an adjustable outlet regulator. Further power savings may be realized by directing only the hot gas to the top of the receiver to minimize the mixing of cold liquid and hot gas. As a result subcooled liquid is fed to the evaporators resulting in increased refrigeration effect and efficiency. Also, the amount of hot gas, that would otherwise condense to waxy liquid, is reduced and a lower cost, smaller regulator can be used. In general, only one third of bypass is needed compared to mixing the gas and liquid entering the receiver.

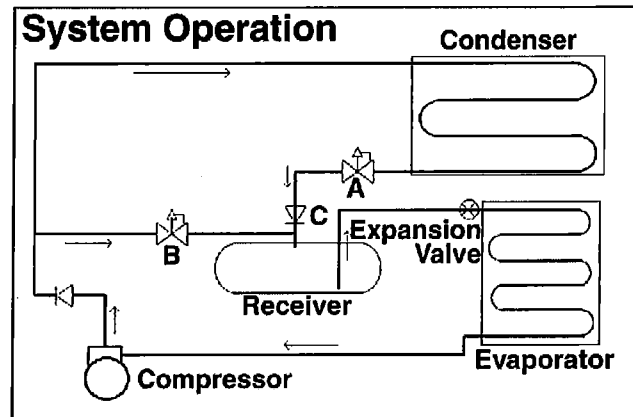

## Valve Functions

Referring to the Figure above, Valve A is an Inlet Pressure Regulator in the liquid drain line from the condenser, and senses the condenser pressure. The regulator closes as the condenser pressure drops below the set point, thus back-flooding the condenser and reducing the inside surface area available for condensing.

Valve B is an Outlet Pressure Regulator in the bypass line from compressor discharge to the condenser liquid drain line. This valve senses the receiver pressure and opens when this pressure drops below the set point, thus maintaining the receiver pressure.

Valve C is an In-line Check Valve in the liquid drain line to prevent higher pressure from backing up into the condenser during low ambient conditions when the compressor is idle.

## Liquid Drain Control Method

This method is ideal for large capacity systems since a smaller regulator is required for liquid line than for discharge line.

During warm ambient temperature conditions valves A and C will be open and Valve B will be closed. When the ambient temperature at the condenser drops, the condenser pressure will tend to become lower. As this pressure is reduced, when the pressure becomes as low as its setting, Valve A will begin to close, thus causing the refrigerant to back up inside the condenser tubes, reducing the condensing surface and allowing the pressure to be maintained. As Valve A closes, the receiver pressure may be reduced by the cold entering liquid to a level below the setting of Valve B, which will begin to open to bypass sufficient gas to maintain the receiver pressure at the set point of Valve B. Check valve C will prevent the high pressure from backing up to the condenser when the receiver pressure is higher than the condenser pressure, as would be the case during shutdown in a system with a warm receiver.

When the condenser pressure builds up to the setting of Valve A, it will open allowing liquid to flow to the receiver.

To describe it again, during cold ambient temperature conditions this liquid will be considerably subcooled and will tend to lower the receiver pressure. Valve B will sense the drop in pressure and open to admit hot gas into the drain line, thus pressurizing and warming the liquid and maintaining the receiver pressure.

## Recommended Valve Settings

Regulators ordered for a Condenser Pressure Control system for use with common refrigerants will be furnished with the ranges and factory settings shown in Table 29. Turning the adjusting stem in (clockwise) will raise the set point; turning the stem out (counterclockwise) will lower the set point. See Table 29 for ranges and amount of pressure change per turn.

**Table 29. Pressure Range, Set Point & Charge Per Turn**

Valve Type		Range		Factory Set Point		Change Per Turn	
		psig	kg/cm <sup>2</sup>	psig	kg/cm <sup>2</sup>	psig	kg/cm <sup>2</sup>
A4A ARA0	D	75 to 280	5.2 to 19.7	140	9.8	53	3.7
A7A A7A1 A72	D	75 to 280	5.3 to 19.7	120	8.4	75	5.3
A9	B	80 to 220	5.6 to 15.5	120	8.4	25	1.8

## Field Adjustment

Before final field adjustment of regulators for Condenser Pressure Control, the following should be done:

1. Install gauges to read compressor discharge, condenser and receiver pressures.
2. Fully charge the system.
3. Have other controls and components functioning properly.
4. Have the system as fully loaded as possible.

5. Final adjustments should be made when the outdoor ambient is below 65°F. Ideally the ambient should be near minimum system outdoor temperature to allow the system pressures to drop below the regulator pressure settings. Before adjusting make sure that all manual opening stems on the regulators are set for automatic operation. It may be necessary to temporarily deactivate the low pressure cut out controls to keep the compressors running during adjustment.
6. The regulators should be preset using information in Table 29.
7. When the valves are adjusted with the system operating, enough time must be allowed for the system to stabilize. Check the sight glass to make sure sufficient liquid is supplied to the evaporators.
8. Turn the condenser fans off to allow the discharge pressure to build up. The regulator A should be adjusted to open when the pressure reaches the desired control point. Listen for flow through regulator A while watching the pressure gauge.

To determine the final setting of regulator B, allow the condenser fans to run long enough to subcool the liquid supplied to the receiver. Adjust the regulator until the desired receiver pressure is obtained. Flow through the valve can be determined by listening at the valve for gas flow or by feeling the outlet for change in temperature. The setting of regulator B should be at least 10 psi lower than the setting of regulator A.

## Hot Gas Bypass Regulator Adjustment

Discharge Bypass Valves (DVB) respond to changes in downstream or suction pressure. When the evaporating pressure is above the valve setting, the valve remains closed. As the suction pressure drops below the valve setting, the valve responds and begins to open. As with all modulating type valves, the amount of opening is proportional to the change in the variable being controlled - in this case the suction pressure. As the suction pressure continues to drop, the valve continues to open farther until the limit of the valve stroke is reached.

On refrigeration systems discharge bypass valves are used to prevent the suction pressure from going below the minimum value determined by the job requirements.

## Sporlan Valve Company

### Valve Setting and Adjustment

A complete discussion on valve settings is given in Sporlan Application Bulletin 90-40. The fully adjustable models ADRS(E)-2, ADRP(E)-3, and ADRH(E)-6 are available with two adjustment ranges - 0/30 and 0/80 psig. The standard factory settings for these are 20 and 60 psig, respectively. The ADRI(E)-1-1/4 is available with a 0/55 psig range and the standard factory setting is 28 psig.

To adjust these valves, remove the cap and turn the adjustment nut with a 5/16" hex wrench for fully adjustable models ADRS(E)-2, ADRP(E)-3, and ADRH(E)-6. The ADRI(E)-1-1/4 model has a 3/8" adjustment screw on top of the adjustment housing. A clockwise rotation increases the setting and a counterclockwise rotation decreases the setting. Adjusting these valves can be complicated because the load

must be varied during the setting procedure and it is difficult to determine exactly when the bypass valve opens unless a pressure gauge can be located at the valve outlet.

Therefore, sufficient load must be available in some form to raise the suction pressure above the desired valve setting. Once this is accomplished, the load can be slowly decreased until the DBV opens (a hissing sound and/or an accompanying pressure rise at the outlet connection will indicate that the bypass valve has opened).

## Alco Controls

### Valve Setting and Adjustment

CPHE and DGRE regulators are commonly used to prevent the suction pressure from falling below a predetermined set point. Complete information about these valves can be found in ALCO CONTROLS Catalog 24-D.

The first step after installation is to determine the set point for the minimum suction pressure allowable for the application. The following procedure should be followed.

1. Start the system and determine if it is operating properly: Install a gauge on the compressor suction line and measure the suction pressure after the system has stabilized. To make certain that hot gas is not being bypassed, listen to the main regulator flow or feel the outlet piping. If the piping is warm, this would indicate hot gas is flowing.
2. Stop the flow of hot gas by de-energizing the hot gas solenoid valve or by turning the power assembly adjusting stem full COUNTERCLOCKWISE.
3. Reduce the evaporator load until the suction pressure lowers to the point at which bypass is desired.
4. If the hot gas solenoid was de-energized to stop hot gas flow, make sure it is now energized.
5. Turn the power assembly adjusting stem in a CLOCKWISE direction until bypass occurs and suction pressure does not fall below the predetermined set point. A CLOCKWISE turn of the adjusting stem will increase the pressure setting; a COUNTERCLOCKWISE turn will decrease it. Standard pressure pilot is adjustable from 0 to 80 psig, with one complete turn equal to approximately 4 psi change. Adjustments should be made in small increments, allowing for the system to stabilize after each turn.
6. Vary the evaporator load to test at various conditions that the suction pressure does not fall below the predetermined set point.
7. Replace the seal cap on the adjusting stem.

## Control Settings

The following tables are for use when mechanical low pressure switches are incorporated for rack pressure control. All control settings are approximate and should be adjusted for actual field conditions and equipment. All settings are based on 10°F TD evaporator.

**Table 30. Control Settings for R-404A/R-507**

Air Temp °F	EPR psig	LP C/I psig	LP C/O psig
38-42	69	72	64
34-38	64	66	57
34-36	60	62	55
33-35	59	61	53
28-32	55	58	50
24-28	48	50	35
-10-/0	21	24	15
-10-/5	20	22	14
-15-/10	15	17	14
-20-/15	12	15	8

**Table 31. Control Settings for R-22**

Air Temp °F	EPR psig	LP C/I psig	LP C/O psig
38-42	54	57	50
34-38	50	48	43
34-36	47	50	41
33-35	45	47	40
28-32	43	45	38
24-28	36	38	25
-10-/0	13	17	8
-10-/5	11	14	7
-15-/10	8	10	5
-20-/15	5	8	2

## Low Pressure Switch Setting for RMCC

Some systems use a form of electronic control such as CPC's RMCC solid state controller for Rack operation. On these systems, there is one mechanical low pressure control for each suction group that may be on the rack. This control is for backup emergency control in the event of a board or other electronic component failure. This low pressure control must be set for the minimum suction pressure that the rack would be expected to operate at to keep from interfering with the RMCC control.

Example, for a low temperature suction group, this control should be set for 0 - 2 psig cutout and approximately 10 psig cutin. A medium temperature suction group can be set higher. In the event that this control is needed to actually control the compressors, set the cutin and cutout for the suction pressure that you want the compressors to operate to maintain case or box temperatures.

**NOTE: This low pressure control will generally be mounted on a compressor with the braided stainless steel tubing connecting to the appropriate suction group header.**



## General Maintenance Schedule

(Service/Maintenance should be performed only by a qualified / certified refrigeration service technician.)

### Weekly

- Check refrigerant charge using the liquid line sight glass
- Check compressor oil level
- Check compressor crankcase heater operation
- Check main power and control voltage
- Check appearance of area around the unit
- Check system pressures

### Monthly

- Check the refrigerant system for leaks
- Check suction filters and liquid line filter driers.
- Check all flanged connection bolts, fittings and line clamps for tightness.
- Inspect condenser fan blades and motor mounts for cracks, loose set screws or mounting bolts.
- Tighten all electrical connections.
- Check operation and condition of contacts on compressor/ fan motor contactors. Check appearance of control panel interior.
- Check appearance of exterior conduit/junction boxes.
- Check appearance of insulation.
- Check operation of auxiliary equipment.

### Quarterly

With unit in stable operation, record all operating conditions:

- Suction/discharge/liquid refrigerant pressure(s) and temperature(s).
- System superheat, liquid subcooling, ambient temperature.
- Compressor amperage.
- Test all operating and safety controls.

### Annually

- Obtain oil sample for analysis. Change oil if required.
- Clean condenser coil.
- Straighten condenser fins as required.
- Change liquid line filter drier and suction filter cores.

**Note: The above information is provided only as a general guideline to aid servicing personnel and equipment owners in maintaining equipment. Due to variables in the actual equipment application, operating conditions, and environment recommended service intervals may vary.**

## SERVICE DIAGNOSIS CHART

Symptom	Cause	Remedy
<b>Compressor Does Not Run</b>	<ol style="list-style-type: none"> <li>1. Motor Line open</li> <li>2. Fuse blown</li> <li>3. Tripped overload</li> <li>4. Control contacts dirty or jammed in open position</li> <li>5. Piston seized</li> <li>6. Frozen compressor or motor bearings</li> </ol>	<ol style="list-style-type: none"> <li>1. Close starter or disconnect switch</li> <li>2. Replace fuse</li> <li>3. See electrical section</li> <li>4. Repair or replace</li> <li>5. Remove motor-compressor head, look for broken valve and jammed parts</li> <li>6. Repair or replace</li> </ol>
<b>Unit Short Cycles</b>	<ol style="list-style-type: none"> <li>1. Control differential set too close</li> <li>2. Discharge valve leaking</li> <li>3. Motor compressor</li> <li>4. Refrigerant shortage</li> <li>5. Refrigerant over charge</li> <li>6. Cycling on high pres. cutout</li> </ol>	<ol style="list-style-type: none"> <li>1. Widen differential</li> <li>2. Replace valve plate</li> <li>3. Check for high head pressure, tight bearings, seized pistons, clogged air-cooled condenser</li> <li>4. Repair leak and recharge</li> <li>5. Remove some refrigerant</li> <li>6. Check condenser / or non condensable in system</li> </ol>
<b>Compressor Will Not Start - Hums Intermittently</b>	<ol style="list-style-type: none"> <li>1. Improperly wired</li> <li>2. Low voltage</li> <li>3. Relay contacts not closing</li> <li>4. Open circuit in start-winding</li> <li>5. Stator winding grounded</li> <li>6. High discharge pressure</li> <li>7. Tight compressor</li> </ol>	<ol style="list-style-type: none"> <li>1. Check wiring against diagram</li> <li>2. Check main line voltage - determine location of voltage drop</li> <li>3. Check my operating manually. Replace relay if defective</li> <li>4. Check stator leads. If leads are all right, replace stator</li> <li>5. Check stator. If leads are all right, replace stator</li> <li>6. Eliminate cause of excessive pressure</li> <li>7. Check oil level. Correct binding</li> </ol>
<b>Unit Operates Long Or Continuously</b>	<ol style="list-style-type: none"> <li>1. Control contacts sticking in closed position</li> <li>2. Insufficient refrigerant in system</li> <li>3. Dirty condenser</li> <li>4. Air or non-condensables in system</li> <li>5. Compressor inefficient</li> <li>6. Improper wiring</li> </ol>	<ol style="list-style-type: none"> <li>1. Clean points or replace control</li> <li>2. Check for leaks. Repair and add charge</li> <li>3. Clean condenser</li> <li>4. Purge high point in system</li> <li>5. Check valves and pistons</li> <li>6. Check wiring and correct if necessary</li> </ol>
<b>Fixture Temperature Too High</b>	<ol style="list-style-type: none"> <li>1. Insufficient refrigerant in system</li> <li>2. Control set too high</li> <li>3. Control wiring loose</li> <li>4. Expansion valve or strainer plugged</li> <li>5. Compressor inefficient</li> <li>6. Expansion valve set too high</li> <li>7. Iced or dirty coil</li> <li>8. Unit too small</li> <li>9. Clogged or small refrigerant lines</li> <li>10. Oil logged in system</li> </ol>	<ol style="list-style-type: none"> <li>1. Check for leaks. Repair and add charge</li> <li>2. Reset control</li> <li>3. Check wiring to control</li> <li>4. Clean or replace</li> <li>5. Check valves and pistons</li> <li>6. Lower setting</li> <li>7. Defrost or clean coil</li> <li>8. Add unit or replace</li> <li>9. Clear line or increase line size</li> <li>10. Remove excessive oil, check refrigerant charge</li> </ol>
<b>High Discharge Pressure</b>	<ol style="list-style-type: none"> <li>1. Refrigerant overcharge</li> <li>2. Non-condensables in system</li> <li>3. Dirty condenser coil</li> <li>4. High side restriction</li> <li>5. Head pressure control setting</li> <li>6. Fan not running</li> </ol>	<ol style="list-style-type: none"> <li>1. Remove the excess</li> <li>2. Remove the non-condensables</li> <li>3. Clean</li> <li>4. Check all valves or remove restriction</li> <li>5. Adjust controls</li> <li>6. Check electrical circuit</li> </ol>

Symptom	Cause	Remedy
<b>Low Discharge Pressure</b>	<ol style="list-style-type: none"> <li>Insufficient refrigerant in system</li> <li>Faulty condenser temp. regulation</li> <li>Compressor suction or discharge valve inefficiencies</li> <li>Low suction pressure</li> <li>Head pressure control valve set wrong or no head pressure control valve</li> </ol>	<ol style="list-style-type: none"> <li>Check for leaks. Repair and add charge</li> <li>Check condenser control operation</li> <li>Clean or replace leaky valve plates</li> <li>See corrective steps for low suction pressure</li> <li>Adjust valve or install a head pressure control valve</li> </ol>
<b>High Suction Pressure</b>	<ol style="list-style-type: none"> <li>Excessive load</li> <li>Expansion valve overfeeding</li> </ol>	<ol style="list-style-type: none"> <li>Reduce load or add additional equipment</li> <li>Check remote bulb. Regulate superheat</li> </ol>
<b>Low Suction Pressure</b>	<ol style="list-style-type: none"> <li>Lack of refrigerant</li> <li>Evaporator dirty or iced</li> <li>Clogged liquid line filter drier</li> <li>Clogged suction line or compressor suction strainer</li> <li>Expansion valve malfunctioning</li> <li>Condensing temperature too low</li> <li>Improper TXV</li> </ol>	<ol style="list-style-type: none"> <li>Check for leaks. Repair and add charge</li> <li>Defrost or clean coil</li> <li>Replace cartridge(s)</li> <li>Clean strainer or replace filters</li> <li>Check and reset for proper superheat</li> <li>Check means for regulating condensing temperature</li> <li>Check for proper sizing</li> </ol>
<b>Little or No Oil Pressure</b>	<ol style="list-style-type: none"> <li>Clogged suction oil strainer</li> <li>Excessive liquid in crankcase</li> <li>Low oil pressure safety switch defective</li> <li>Worn oil pump</li> <li>Oil pump reversing gear stuck in the wrong position</li> <li>Low oil level</li> <li>Worn bearings</li> <li>Loose fitting on oil lines</li> <li>Pump house gasket leaks</li> </ol>	<ol style="list-style-type: none"> <li>Clean</li> <li>Check crankcase heater. Reset TXV for higher superheat. Check liquid line solenoid valve for proper operation.</li> <li>Replace</li> <li>Replace</li> <li>Reverse direction of compressor rotation</li> <li>Determine where the oil is or add oil</li> <li>Replace compressor</li> <li>Check and tighten fittings</li> <li>Replace gasket</li> </ol>
<b>Compressor Loses Oil</b>	<ol style="list-style-type: none"> <li>Lack of refrigerant</li> <li>Excessive compression ring blowby</li> <li>Refrigerant floods back</li> <li>Improper piping or traps</li> </ol>	<ol style="list-style-type: none"> <li>Check for leaks. Repair and add charge</li> <li>Replace compressor</li> <li>Maintain proper superheat at compressor</li> <li>Correct piping</li> </ol>
<b>Compressor Thermal Protector Switch Open</b>	<ol style="list-style-type: none"> <li>Operating beyond design limits</li> <li>Discharge valve partially shut</li> <li>Blown valve plate gasket</li> <li>Dirty condenser coil</li> <li>Overcharged system</li> </ol>	<ol style="list-style-type: none"> <li>Add facilities so that conditions are within allowable limits</li> <li>Open valve</li> <li>Replace gasket</li> <li>Clean coil</li> <li>Reduce charge</li> </ol>

# SERVICE RECORD

A permanent data sheet should be prepared on each installation, with a copy for the owner and the original for the installing contractor's files. If another firm is to handle service and maintenance, additional copies should be prepared as necessary.

## System Reference Data

The following information should be filled out and signed by the Refrigeration Installation Contractor.

Date System Installed: \_\_\_\_\_ Date Started: \_\_\_\_\_

Installer and Address: \_\_\_\_\_  
\_\_\_\_\_  
\_\_\_\_\_

Job Name / Location: \_\_\_\_\_  
\_\_\_\_\_  
\_\_\_\_\_

Compressor Unit Model: \_\_\_\_\_

Compressor Unit Serial No.: \_\_\_\_\_

Electrical: \_\_\_\_\_ Phase: \_\_\_\_\_

Condenser Model: \_\_\_\_\_ Serial No.: \_\_\_\_\_

Design SST: Group \_\_\_\_\_ Group \_\_\_\_\_ Group \_\_\_\_\_

Compressor Model / Serial No. \_\_\_\_\_ / \_\_\_\_\_ Group: \_\_\_\_\_

Compressor Model / Serial No. \_\_\_\_\_ / \_\_\_\_\_ Group: \_\_\_\_\_

Compressor Model / Serial No. \_\_\_\_\_ / \_\_\_\_\_ Group: \_\_\_\_\_

Compressor Model / Serial No. \_\_\_\_\_ / \_\_\_\_\_ Group: \_\_\_\_\_

Compressor Model / Serial No. \_\_\_\_\_ / \_\_\_\_\_ Group: \_\_\_\_\_

Compressor Model / Serial No. \_\_\_\_\_ / \_\_\_\_\_ Group: \_\_\_\_\_

Evacuation: # Times \_\_\_\_\_ Final Micron: \_\_\_\_\_

System Suction P (Group \_\_\_\_): \_\_\_\_\_ System Discharge P: \_\_\_\_\_

System Suction P (Group \_\_\_\_): \_\_\_\_\_ System Discharge P: \_\_\_\_\_

System Suction P (Group \_\_\_\_): \_\_\_\_\_ System Discharge P: \_\_\_\_\_

Ambient: \_\_\_\_\_

Superheat at Compressors: \_\_\_\_\_

*Since product improvement is a continuing effort, we reserve the right to make changes in specifications without notice.*

The name behind the brands you trust. 